

Woody Log Loader
Operator's Manual
Models 115 HD - 115
HDT - 125 LP

Woody Equipment Inc., 205 rue Commercial, Saint-Odilon-de-Cranbourne, Quebec, Canada G0S3A0
T. (418) 464-2748 F. (418) 464-2746 Email: ewoody@sogetel.net <mailto:ewoody@sogetel.net>
Website: www.equipementswoody.com <http://www.equipementswoody.com/>
Facebook: Équipements Woody



Woody Equipment Inc.
Owners: Jerome and Sebastien Labbe

205 rue Commerciale
Saint-Odilon-de-Cranbourne
Beauce-Nord, Quebec,
Canada G0S 3A0

T. (418) 464-2748

F. (418) 464-2746

Email: ewoody@sogetel.net
<<mailto:ewoody@sogetel.net>>

Website: www.equipementswoody.com

<<http://www.equipementswoody.com/>>

Facebook: Les Equipements Woody

Woody Equipment Inc.

© All Rights Reserved: Woody Equipment Inc. of Saint-Odilon-de-Cranbourne.

No part of this manual may be reproduced in any form without the written permission of Woody Equipment Inc.



table of contents

Introduction.....	1
Warning.....	2
Characteristic of the loader 115HD.....	3
115HD Loader Parts List.....	4
Characteristic of the loader 115 HDT.....	5
115 HDT Loader Parts List.....	6
Characteristic of the loader 125 LP.....	7
125 LP Loader Parts List.....	8
Characteristic of the trailer 10-66 tires 11L15.....	9
Characteristic of the trailer 10-66 tires 12.5L15.....	10
Characteristic of the trailer 10-66LP tires 11L15.....	11
Parts list grapple 36".....	12
Parts list 6000lb winch high.....	13
Parts list 6000lb winch low.....	14
Parts list simple hydraulic directional.....	15
Operation.....	16
Safety Instructions.....	17-25



Introduction

Congratulations on your purchase of a Woody Log Loader. Woody Equipment designs and manufactures equipment according to very strict criteria. This equipment is intended for professional use in the agricultural and forestry sectors.

Even if you have experience with this type of product, we recommend that you read these instructions carefully. These instructions contain important information on safety and efficiency and to ensure the validity of the factory guarantee.

Woody Equipment reserves the right to modify and / or improve its equipment and maintenance instructions, as well as to revise data without notice.

Write down the serial number, model number, purchased date, dealer name, and sales representative's name. Keep this information available for ordering parts as well as for any technical assistance or warranty issue.

Serial number	
Model number	
Purchased date	
Dealer	
Sales representative	



Warning

The following symbols used in this manual are to warn the operator of the dangers connected to the use of this machinery. Follow the safety instructions to avoid any risk of serious injury or death.

	AVERTISSEMENT
	CHUTE DE LA CHARGE OU DES MÂTS Peut causer de graves blessures ou la mort. Ne jamais déplacer la charge ou les mâts au-dessus du personnel.
	WARNING
	FALLING BOOM OR LOAD Can cause severe injuries or death. Do not move boom or load over people.
<small>ALFACOLLAS TUBES S/A - 30 000 20</small>	

	AVERTISSEMENT
	RISQUE D'ECRASSEMENT Les stabilisateurs peuvent causer de graves blessures ou la mort. Gardez le personnel éloigné des stabilisateurs.
	WARNING
	CRUSHING HAZARD Stabilizers can cause severe injuries or death. Keep bystanders away from stack zone.
<small>ALFACOLLAS TUBES S/A - 30 000 20</small>	

	AVERTISSEMENT
	MACHINE INSTABLE Toujours opérer la chargeuse avec les stabilisateurs abaissés sur un sol ferme et au niveau. Assurez- vous d'avoir une stabilité adéquate.
	WARNING
	UNSTABLE MACHINE Do not operate loader without lowering the stabilizers on firm level ground and checking for adequate stability.
<small>ALFACOLLAS TUBES S/A - 30 000 20</small>	

	DANGER
	ÉLOIGNEZ-VOUS STAY AWAY
<small>ALFACOLLAS TUBES S/A - 30 000 20</small>	

	AVERTISSEMENT
<p>C'est à l'opérateur de cette chargeuse d'être qualifié et entraîné avant d'opérer cet équipement. Observez les lois fédérales et provinciales sur les règlements de sécurité concernant notamment les travaux particuliers à effectuer. Ne jamais dépasser les recommandations techniques recommandées de la chargeuse ou de l'attachement. Il est important de suivre les instructions sur les relevés de sécurité. Informez les autres de la présence de l'opérateur de la chargeuse et de la zone de travail, sinon des blessures ou même la mort peuvent en résulter.</p>	
	WARNING
<p>Any operator of this loader must be fully trained and qualified to do so. Observe all state or provincial safety regulations relating to the particular work being performed. Never exceed recommended technical specifications of the loader or its attachments. Injury, including death may result from failure to follow this warning and/or the information contained in the loader operator's manual/technical specifications sheet.</p>	
<small>ALFACOLLAS TUBES S/A - 30 000 20</small>	

DANGER 20M ZONE AREA



115 HD LOADER PARTS LIST

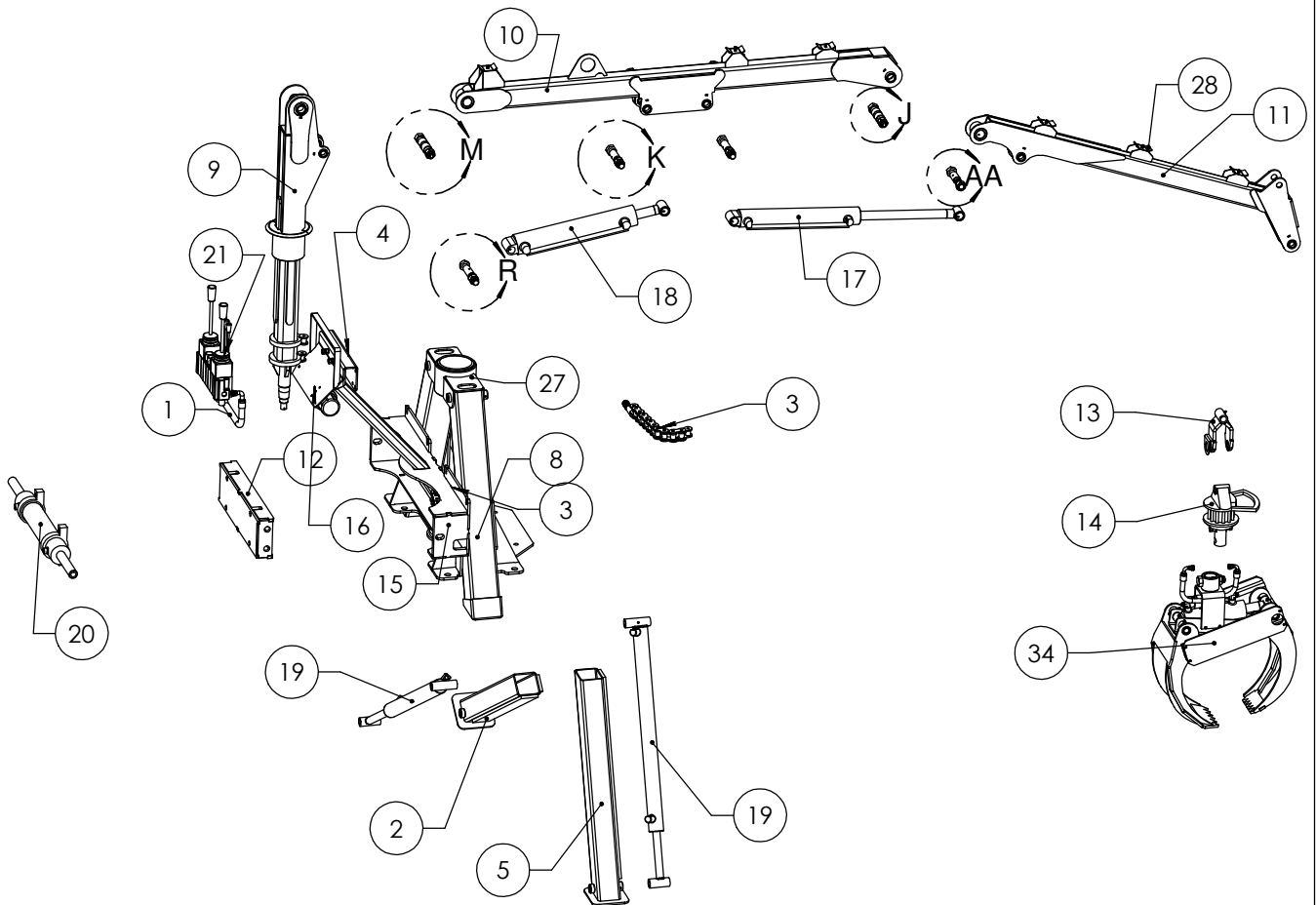
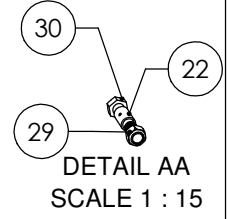
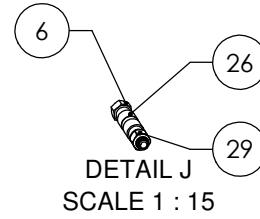
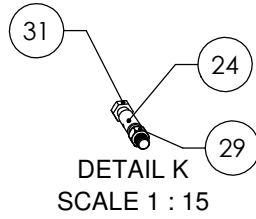
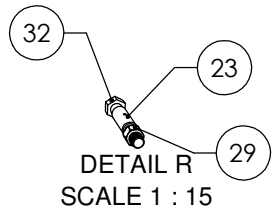
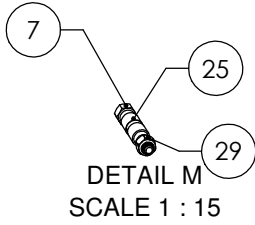



115 HD Loader
Parts List

Item	Part #	Description	Qty
1	140040-020-100600-100600	Hose assembly 1/2" - 20" long	1
2	60-012-06	Loader telescopic stabilizers 115,125 LP	1
3	60-003-08	Rotation chain 115, 125	2
4	60-010-04	Loader control valve support 115, 125, 130,150, 170	1
5	60-012-05	Loader telescopic stabilizers 115, 125 LP	1
6	60-012-07	Main boom loader pin 115, 125	1
7	60-012-08	Stick boom loader pin 115, 125	1
8	60-021-15	Loader A-Frame 115 HD	1
9	60-021-02	Loader column	1
10	60-021-03	Loader main boom 115 HD	1
11	60-021-04	Loader stick boom 115 HD	1
12	60-021-16	Loader swing slider 115, 125	1
13	57-000-04	Grapple yoke	1
14	199309	GR30 Rotator	1
15	306201	Wheel bearing	1
16	400500	Document holder	1
17	120322	Hydraulic cylinder 2 1/2" x 16" stroke	1
18	120483	Hydraulic cylinder 3" x 16" stroke	1
19	120212	Hydraulic cylinder 2" x 30" stroke	2
20	121090	Double action Hydraulic cylinder 3" X 16"	1
21	130240	Anti-shock Q30/7 control	1
22	89-20-16-36-D18-00	Plastic tubing 1 1/4" O.D.	1
23	89-20-16-52-D26-00	Plastic tubing 1 1/4" O.D.	1
24	89-20-16-44-D22-00	Plastic tubing 1 1/4" O.D.	2
25	89-24-20-56-D28-00	Plastic tubing 1 1/2" O.D.	1
26	89-24-20-48-D24-00	Plastic tubing 1 1/2" O.D.	1
27	60-012-028	Rotation plastic sleeve	1
28	60-000-060	Hose lock	6
29	301500	Nylon nut 1"-8	7
30	300320	Bolt 1"-8 x 6" long	1
31	300330	Bolt 1"-8 x 6 1/2" long	2
32	300340	Bolt 1"-8 x 7" long	1
34	57-002	Grappin 36"	1



115 HDT Loader Parts List

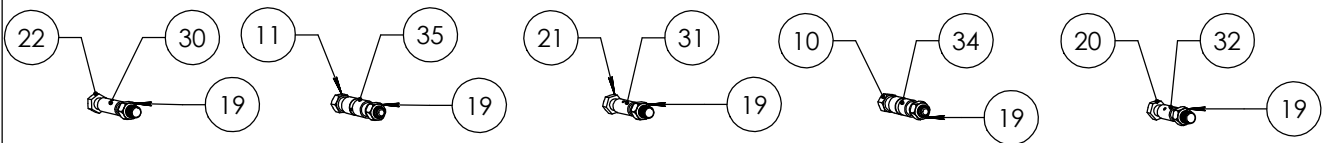

DETAIL AV
SCALE 1 : 16

DETAIL AU
SCALE 1 : 16

DETAIL AT
SCALE 1 : 16

DETAIL AR
SCALE 1 : 16

DETAIL AP
SCALE 1 : 16

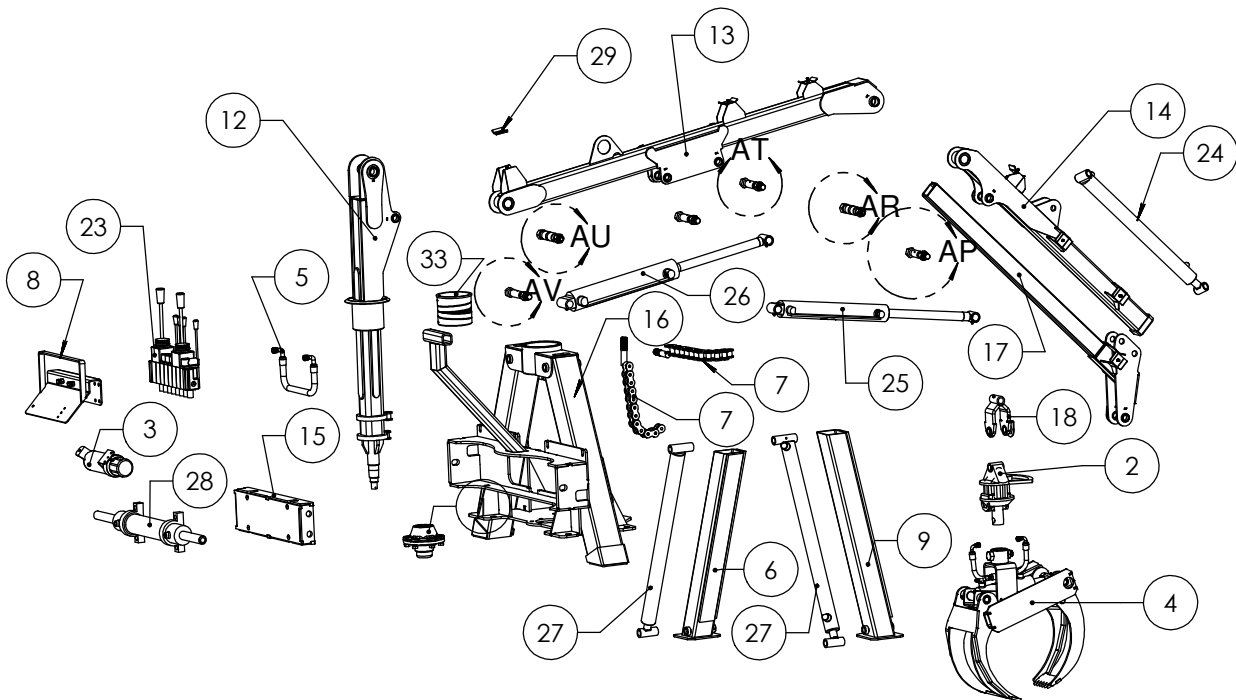



115 HDT Loader Parts List

Item	Part #	Description	Qty
1	306201	Wheel bearing	1
2	199309	GR30 Rotator	1
3	400500	Document holder	1
4	57-002	36" Grapple	1
5	140040-020-100600-100600	Hose assembly 1/2" - 20" long	1
6	60-012-06	Loader telescopic stabilizer 115, 125 LP	1
7	60-003-08	Rotation chain 115, 125	2
8	60-010-04	Loader control valve support 115, 125, 130,150 & 170	1
9	60-012-05	Loader telescopic stabilizer 115, 125 LP	1
10	60-012-07	Stick boom pin 115, 125	1
11	60-012-08	Main boom pin - 115, 125	1
12	60-021-02	Loader column	1
13	60-027-02	Loader main boom 115 HDT	1
14	60-027-01	Loader stick boom 115 HDT	1
15	60-021-16	Loader swing slider 115-125	1
16	60-021-15	Loader A-Frame 115 HD	1
17	60-027-03	Telescope 115	1
18	57-000-04	Grapple yoke	1
19	301500	Nylon nut 1"-8	6
20	300320	Bolt 1"-8 x 6" long	1
21	300330	Bolt 1"-8 x 6 1/2" long	2
22	300340	Bolt 1"-8 x 7" long	1
23	130250	Anti-shock Q30/8 control	1
24	120190	Hydraulic cylinder 2" x 24" stroke	1
25	120322	Hydraulic cylinder 2 1/2" x 16" stroke	1
26	120483	Hydraulic cylinder 3" x 16" stroke	1
27	120212	Hydraulic cylinder 2" x 30" stroke	2
28	121090	Double action hydraulic cylinder 3" X 16"	1
29	60-000-060	Hose lock	7
30	89-20-16-52-D26-00	Plastic tubing 1 1/4" O.D.	1
31	89-20-16-44-D22-00	Plastic tubing 1 1/4" O.D.	2
32	89-20-16-36-D18-00	Plastic tubing 1 1/4" O.D.	1
33	60-012-028	Rotation plastic sleeve	1
34	89-24-20-48-D24-00	Plastic tubing 1 1/2" O.D.	1
35	89-24-20-56-D28-00	Plastic tubing 1 1/2" O.D.	1



125 LP Loader Parts List

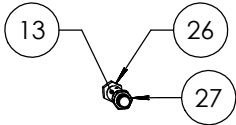

DETAIL AN
SCALE 1 : 15

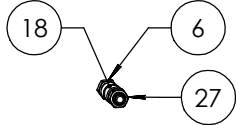

DETAIL AM
SCALE 1 : 15

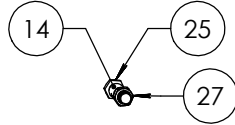

DETAIL AL
SCALE 1 : 15

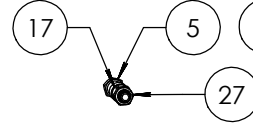

DETAIL AK
SCALE 1 : 15

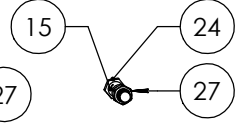

DETAIL AJ
SCALE 1 : 15

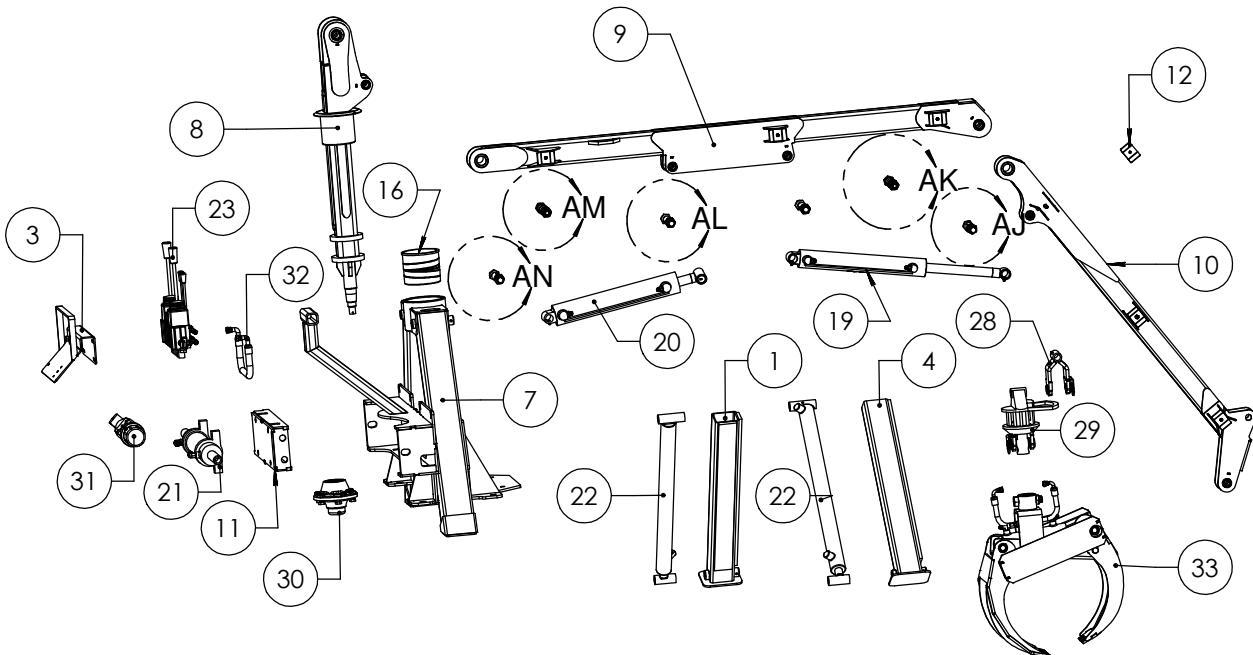



125 LP Loader
Parts List

Item	Part #	Description	Qty
1	60-012-06	Loader telescopic stabilizer 115, 125 LP	1
2	60-003-08	Rotation chain 115,125	2
3	60-010-04	Loader control valve support 115, 125, 130,150 & 170	1
4	60-012-05	Loader telescopic stabilizer 115, 125 LP	1
5	60-012-07	Loader stick boom pin 115, 125	1
6	60-012-08	Loader main boom pin 115, 125	1
7	60-033-01	Loader A-Frame 125 LP	1
8	60-033-02	Loader column 125 LP	1
9	60-033-03	Loader main boom 125 LP	1
10	60-033-04	Loader stick boom 125 LP	1
11	60-021-16	Loader swing slider 115, 125	1
12	60-000-060	Hose lock	6
13	89-20-16-52-D26-00	Plastic tubing 1 1/4" O.D.	1
14	89-20-16-44-D22-00	Plastic tubing 1 1/4" O.D.	2
15	89-20-16-36-D18-00	Plastic tubing 1 1/4" O.D.	1
16	60-012-028	Rotation plastic sleeve	1
17	89-24-20-48-D24-00	Plastic tubing 1 1/2" O.D.	1
18	89-24-20-56-D28-00	Plastic tubing 1 1/2" O.D.	1
19	120322	Hydraulic cylinder 2 1/2" x 16" stroke	1
20	120483	Hydraulic cylinder 3" x 16" stroke	1
21	121090	Double action hydraulic cylinder 3" X 16"	1
22	120212	Hydraulic cylinder 2" x 30" stroke	2
23	130240	Anti-shock Q30/7 control	1
24	300320	Bolt 1"-8 x 6" long	1
25	300330	Bolt 1"-8 x 6 1/2" long	2
26	300340	Bolt 1"-8 x 7" long	1
27	301500	Nylon nut 1"-8	6
28	57-000-04	Grapple yoke	1
29	199309	GR30 Rotator	1
30	306201	Wheel bearing	1
31	400500	Document holder	1
32	140040-020-100600-100600	Hose assembly 1/2" - 20" long	1
33	57-002	36" Grapple	1



10-66 Forestry Trailer with 11L15 Tires Parts List

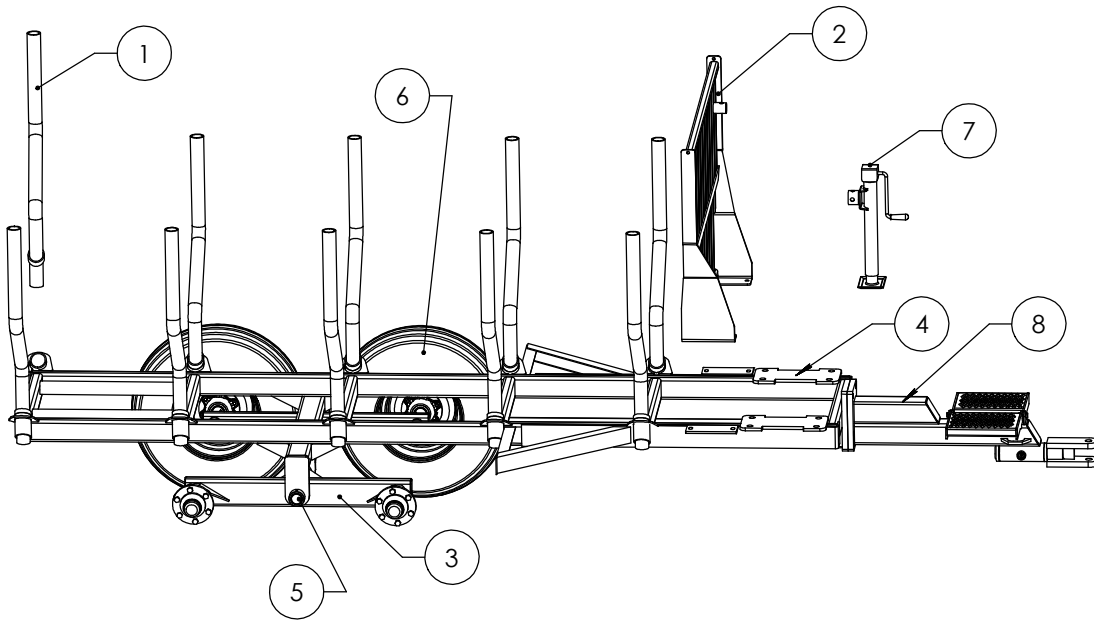

10-66 Forestry Trailer with 11L15 Tires Parts List

Item	Part #	Description	Qty
1	59-00-04	10-66 Trailer post	10
2	59-000-05	Protective grid 38" wide x 38" high	1
3	59-026-03	Tandem trailer	2
4	59-011-01	10-66 Forestry trailer frame - 115 HD	1
5	86-31-285-F12-00	Shaft 1 15/16" O.D.	2
6	302010	11L15 Tire, 8-ply, 6 nuts, 5000 lb.	4
7	303020	Trailer Jack - 6000 or (5000) lb.	1
8	59-076-01	Removable drawbar	1



10-66 Forestry Trailer with 12.5L15 Tires Parts List

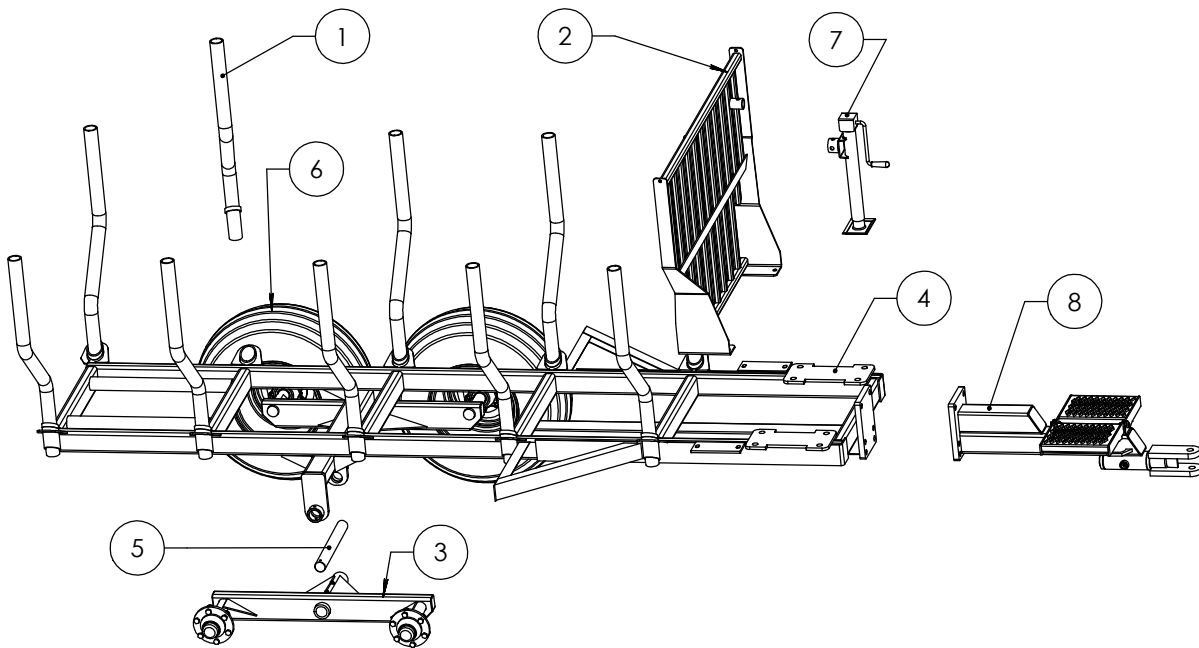

10-66 Forestry Trailer with 12.5L15 Tires Parts List

Item	Part #	Description	Qty
1	59-000-04	10-66 Trailer post	10
2	59-000-05	Protective grid 38" wide x 38" high	1
3	59-026-03	Tandem trailer	2
4	59-011-01	10-66 Forestry trailer frame - 115 HD	1
5	86-31-285-F12-00	Shaft 1 15/16" O.D.	2
6	302020	12.5L15 Tire, 10-ply, 6 nuts	4
7	303020	Trailer Jack - 6000 or (5000) lb.	1
8	59-076-01	Removable drawbar	1



10-66LP Forestry Trailer 11L15 Tires Parts List

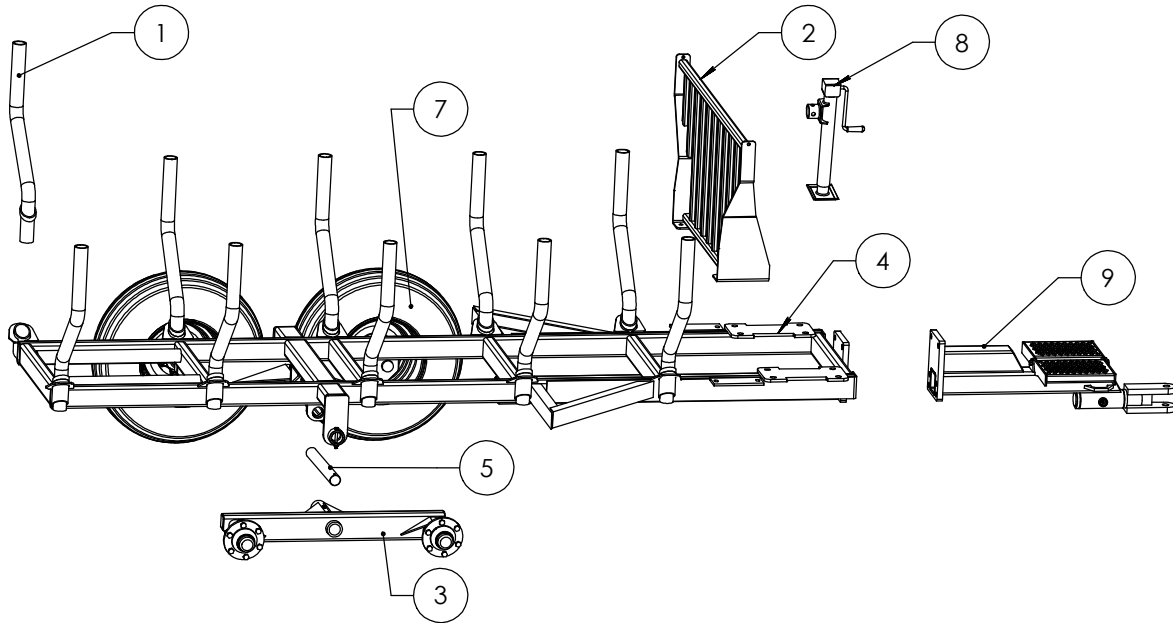

10-66 Forestry Trailer with 11.5L15 Tires Parts List

Item	Part #	Description	Qty
1	59-000-33	10-66 trailer short post	10
2	59-000-32	Protective grid 38" wide x 38" high	1
3	59-026-03	Tandem trailer	2
4	59-175-01	10-66 Forestry trailer frame 125 HD	1
5	86-31-285-F12-00	Shaft 1 15/16" O.D.	2
6	301550	Nylon nut 3/8"-16	2
7	302010	11.5L15 Tire, 8-ply, 6 nuts, 5000 lb	4
8	303020	Trailer Jack - 6000 or (5000) lb.	1
9	59-076-01	Removable drawbar	1

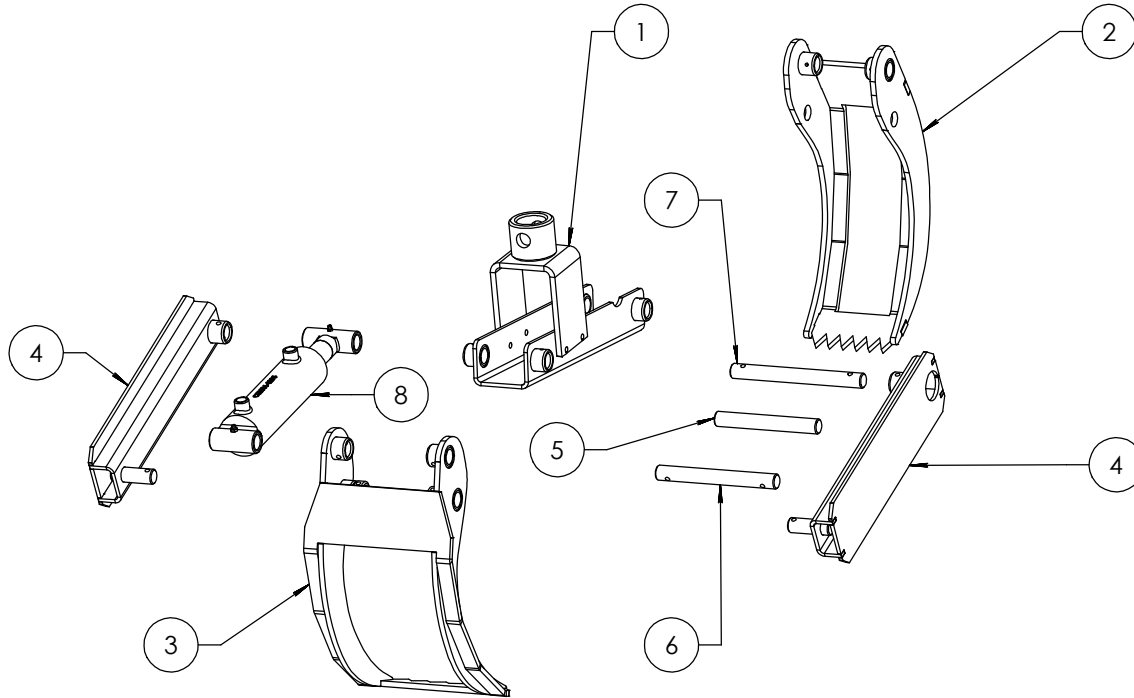

Parts list Grapple 36"

Item	Parts #	Description	Qty
1	57-002-01	Grapple 36" center	1
2	57-002-02	Little finger grapple	1
3	57-002-03	Wide finger grapple	1
4	57-002-03	Side plate grapple	2
5	86-16-120	Rod 1" O.D.	1
6	86-16-140-E14-00- E126-00	Rod 1" O.D.	1
7	86-16-154-E14-00- E138-00	Rod 1" O.D.	1
8	120272	Hydraulic cylinder 2 1/2" Dia. x 6" stroke	1

Les équipements
Woody
Equipment

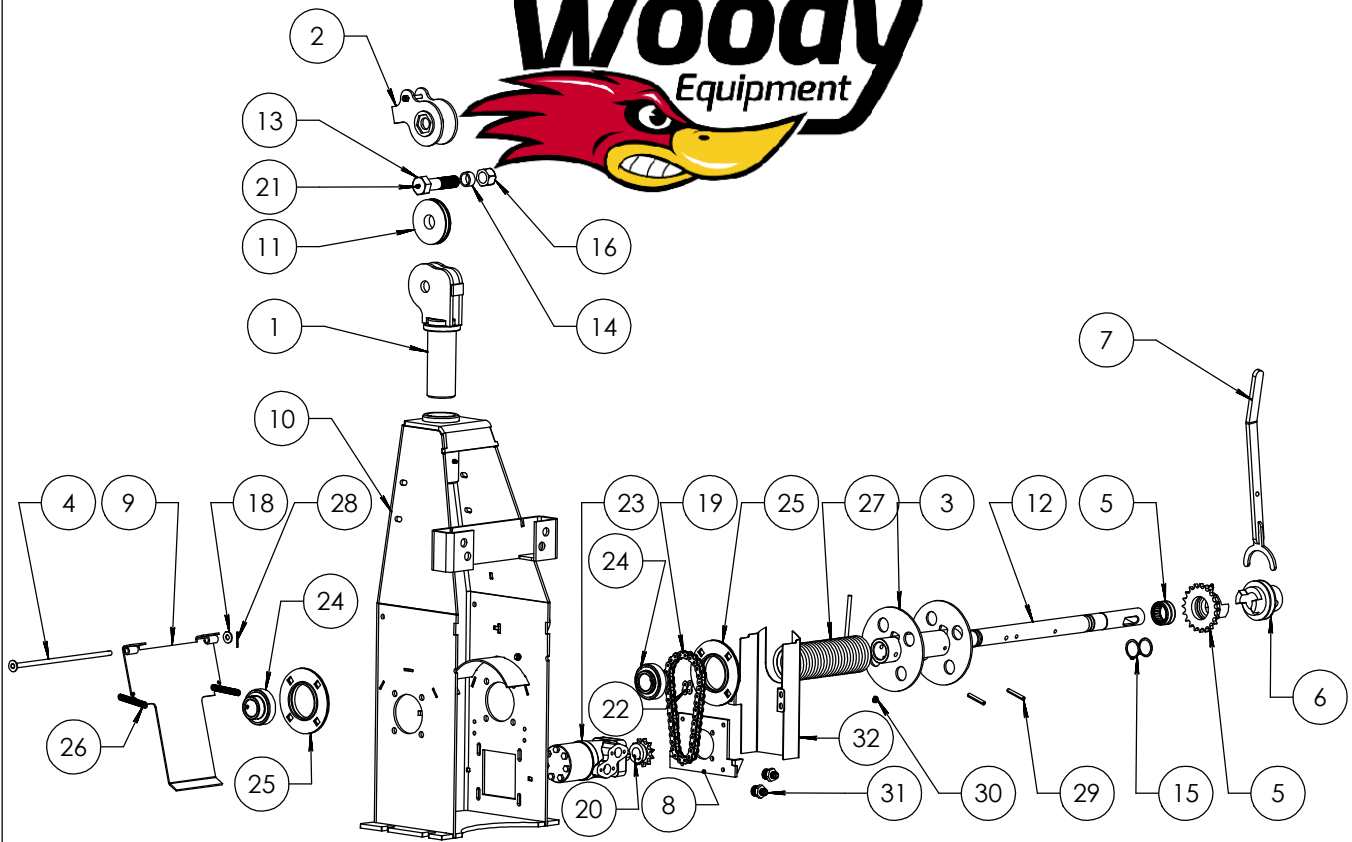

Parts list
Winch 6000lbs

Item	Part#	Description	Qty
1	58-007-02	Winch head	1
2	58-000-04	Swivel head fixation- large, medium, small	1
3	58-000-05	Winch roller- large, Medium	1
4	58-007-03	Cable tensioner pin	1
5	58-000-06	Winch fixed clutch- Large, Medium, Small	1
6	58-000-07	Winch fixed clutch- Large, Medium, Small	1
7	58-000-08	Clutch arm- Large, Medium	1
8	58-000-01	Winch motor support- Large, Medium	1
9	58-007-05	Winch tensioner- Large, Medium	1
10	58-007-04	36" Winch housing	1
11	58-000-024	Modified pulley	1
12	58-000-020	36" Winch roller axis	1
13	58-000-006	Modified bolt	1
14	58-007-019	Plastic tubing 1 1/4" O.D.	1
15	307036	Snap-Ring 1 1/2"	2
16	301500	Nylon nut 1"-8	1
17	300700	Bolt 5/16"-18 x 1"	1
18	301350	Washer 3/8"	2
19	1RIV 50	Chaine series #50 - 36 rollers	1
20	150010	Gear wheel #50-11 teeth heavy duty	1
21	310020	Zote straight 1/4"-28	2
22	309030	Quik linck #50	1
23	108070	Hydraulic motor 315cc	1
24	150040	Bearing insert	2
25	150151	Flange bearing	2
26	309200	Spring	2
27	304010	Nylon cable 5/16" x 110' long	1
28	195-145	Cotter pin 3/32 DIA. X 3/4" LG.	1
29	310880	Spring pin 5/16" O.D. x 2"	2
30	VSPC-06-08	Screw allen 3/8" Dia. X 1/2" Long	1
31	102710	Male 3/8" - JIC x Male 7/8" - ORB	2
32	58-005-011	Winch protector	1



6000 lb. Hydraulic Winch Parts list

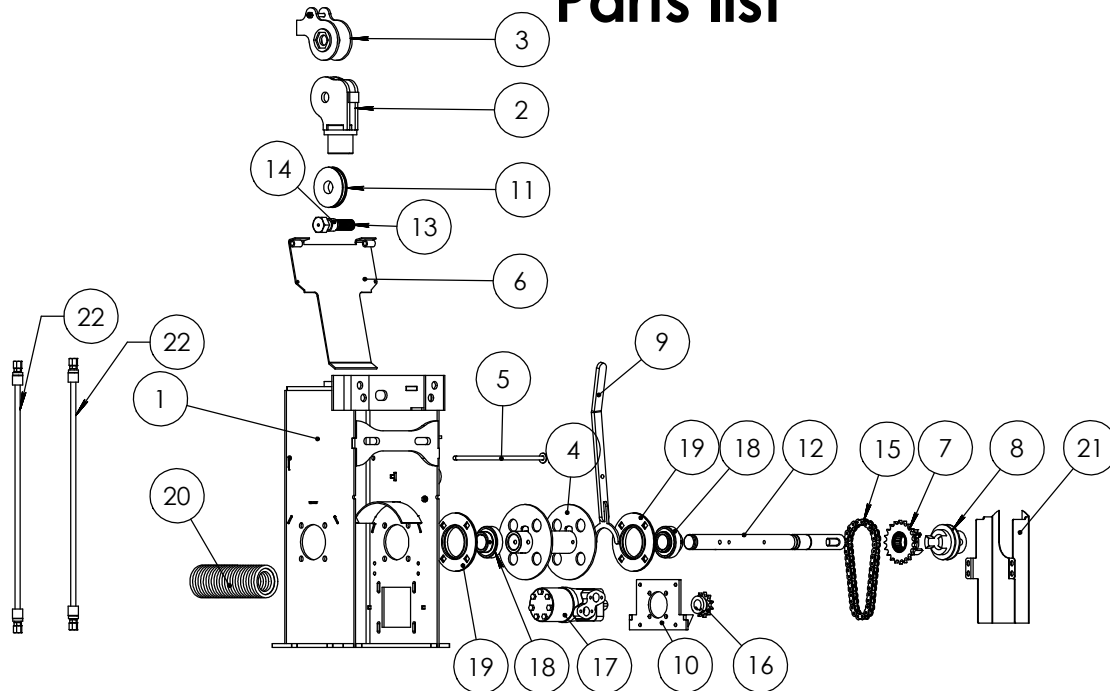

6000 lb. Hydraulic Winch Parts list

Item	part #	Description	Qty
1	58-013-01	26" Winch housing	1
2	58-013-04	Winch head	1
3	58-000-04	Swivel head fixation - Large, Medium, Small	1
4	58-000-05	Winch roller - Large, Medium	1
5	58-007-03	Cable tensioner pin	1
6	58-007-05	Winch tensioner - Large, Medium	1
7	58-000-06	Winch fixed clutch - Large, Medium, Small	1
8	58-000-07	Winch mobile clutch - Large, Medium, Small	1
9	58-000-08	Clutch arm - Large, Medium	1
10	58-000-01	Winch motor support - Large, Medium	1
11	58-000-024	Modified pulley	1
12	58-000-020	36" Winch roller axis	1
13	58-000-006	Modified bolt	1
14	Bush plast 1 1/4 ext x 1 int	Plastic tubing 1 1/4" O.D.	1
15	1RIV 50	Chain series #50 - 36 rollers	1
16	150010	Gear wheel #50-11 teeth heavy-duty	1
17	108070	Hydraulic motor 315 cc	1
18	150040	Bearing insert	2
19	150151	Flange bearing	2
20	304010	Nylon cable 5/16" x 110' long	2
21	58-005-011	Winch protector	1
22	140030-055-101820-101820	Hydraulic hose	2

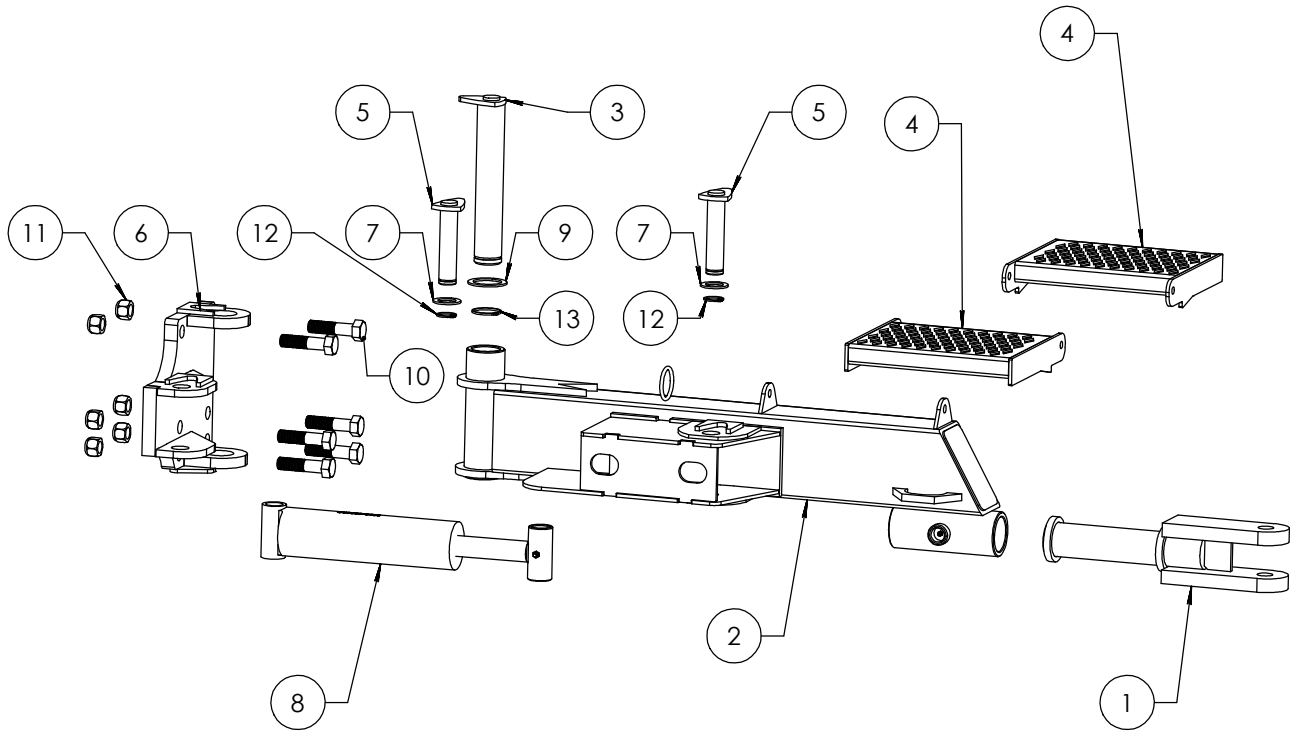

Parts list simple directional

Item	Parts #	Description	Qty
1	59-003-08	Hitch	1
2	59-076-24	Simple directional frame	1
3	59-076-08	Pivot lock	1
4	59-076-09	Deck span 9.5	2
5	59-076-04	Pivot lock	2
6	59-076-02	Pivot simple directional	1
7	59-076-035	washer	2
8	120442	Hydraulic cylinder 3" Dia. x 16" Stroke	1
9	59-076-034	Washer	1
10	301020	Bolt 7/8"-9 x 3 1/2"	6
11	301590	Nylon nut 7/8"-9	6
12	307063	Snap-Ring 1 1/4"	2
13	307075	Snap-Ring 2"	1



Operation

General safety rules:

Read this instruction manual carefully before starting the loader. The technical data in this manual contains important information. Improper use can result in injury and damage to the machine .

Using a loader requires increased knowledge and experience. You must learn and know the behavior of the loader and practice using it. Study and practice the movement patterns with small loads until you master the machine completely. Stop all operations immediately if any bystanders enter the work zone (20 m).

Woody loaders are intended for normal use in the agricultural and forestry sectors. They must be used only by persons trained in the handling of this type of machinery.

- . Before connecting the loader to the tractor's hydraulic system, you must read the tractor's instruction manual to ensure proper connections.
- . Be extremely careful when connecting the loader to the tractor or the trailer to the tractor, as well as when detaching it.
- . When operating, make sure everyone remains in the safety zone, outside of the loader risk area. The operator must have full visibility of the work zone.
- . When operating, do not insert your hand or any other part of your body into the machine or under the load. Do not risk getting stuck between the different parts of the log loader or between the tractor and the trailer.
- . Do not forget to raise the stabilizers before moving the equipment.
- . When loading, always engage the tractor handbrake.
- . Never leave the boom in a raised position without having control of the loader.
- . Never use the loader to pull, push or hit.
- . Be particularly careful when loading and unloading heavy materials.
- . Never use the loading device during transport.
- . To stop the machine, lower the loader boom and grapple on a firm surface, turn off the engine, engage the handbrake and remove the key from the ignition to prevent unauthorized use.
- . The loader is not intended for lifting people.
- . Be very careful when loading or unloading near high voltage lines. Keep a safe distance from live cables.



Safety Instructions

If the overload protection of the hydraulic system is not properly adjusted or certain system functions are altered, safety cannot be ensured.

- . Always lower the hydraulic stabilizers before each operation to avoid overturning.
- . Always check that any unauthorized personnel remains outside the work risk area.
- . Never stand under a suspended load.
- . Make sure that the tractor and trailer are always on firm ground so that there is no risk of overturning. When loading, use the stabilizers to prevent tilting of the loader.
- . Make sure you always have a visual view of the work area.
- . Do not work in conditions where you may get your fingers caught or hurt yourself

When there is a risk of overturning, immediately lower the stick boom with the control lever.

- . Hold the lever in this position until the load is on the ground. Do not interrupt the lowering movement as the risk of overturning will increase if the load stops abruptly.
- . If the tractor rolls over, follow the instructions in the cab. Do not jump out of the cab. You could end up under the load during a fall or under the tractor.

Note: Even if the stabilizers have been lowered to the ground, the risk of overturning is greater when the trailer is empty or partially loaded.

Cracks in hydraulic hoses

- . In the event of pressure loss in the hydraulic fluid or cracks in the hydraulic hoses, you must immediately shut down the tractor engine and lower the load to the ground. Stop the hydraulic flow. Repair the leak.
- . If the main pressure hose between the tractor and the control system is cracked, you must interrupt the oil flow by disconnecting the lever control associated with the tractor's hydraulic distributor or by shutting off the engine with the OFF button.



Safety Instructions

Driving on the Road

Observe the following instructions to avoid any risk of accident.

Position During Transport

- . If there is no load, position the loader boom as low as possible on the trailer. Make sure that the grapple and the rotator are firmly attached to the trailer, so that there is no risk of the loader rolling over during transport.
- . Make sure that none of the additional equipment connected to the loader is likely to cause an accident during transport.

Control is Important

- . You must constantly be in control of the machine at all times and in all situations.
- . Check that the "slow vehicle" plate and the reflective signals are correctly positioned. Check if the trailer lights are functioning correctly and check the tire pressure.
- . The total permitted weights (in particular the weight of the axle) and the transport dimensions must never be exceeded.
- . You must adapt your speed to the driving situation. Drive with caution when one side is tilted, as well as on sloping ground. There is a risk of over turning.
- . Respect the laws of the road and applicable regulations.
- . The braking distance of a tractor equipped with a trailer is longer than for other vehicles, beware of the risk of skidding and check for irregularities in the road.
- . Secure the load and other loose parts securely.

Oil and Grease Caution

- . Avoid any oil or grease contact with the skin during maintenance. Wear appropriate protective clothing.
- . Never wash your hands with lubricating oil or grease. It may damage your skin. If your skin is irritated after contact with oil or grease, contact a doctor immediately.
- . When servicing, waste oil should be disposed of in accordance with local regulations.



Safety Instructions

Welding Repair

. If a repair or modification requires the welding of certain parts, you must first contact your dealer for necessary instructions. Improper welding or negligence during welding can cause sudden machine breakdowns.

Working in Extreme Conditions

. The recommended ambient temperature for the operation of this machine is between -20°C and $+30^{\circ}\text{C}$. Low or high temperatures result in increased wear and stress on joints and hoses. In addition, steel wears faster, and cracks can occur.

. When working in extreme conditions, reduce loads to prevent damage. In case of low temperature let the hydraulic oil circulate freely during several minutes. Then operate each function several times to soften the joints and hoses before applying full pressure. When it is extremely hot, pay attention to the oil temperature. A temperature above 80°C alters the properties of the oil and damages joints and hoses.

Maintenance and Servicing Safety Instructions

. Regular maintenance and service ensure optimal and cost effective operation.

. Note: Failure to follow the instructions in this manual will void all warranties related to this machine. Regular and proper maintenance are a prerequisite for warranty coverage.

. Read the instructions before servicing the machine. Each maintenance task requires reading and following instructions. Maintenance and lubrication should be done at the recommended intervals.

. Always use tools suitable for the maintenance / servicing tasks involved. Wear protective clothing and glasses.

. Shut off the tractor engine and remove the ignition key. If the engine has to run during certain maintenance operations, please stay away from any moving parts of the machine.

. Be extremely careful with pressurized oil. Oil under high pressure easily penetrates the skin. In case of accident, consult a doctor immediately.



Maintenance and Servicing Safety Instructions

- . Hot oil can cause burns. Inhalation of hot oil vapor can cause breathing difficulties.
- . If a hose bursts and you get oil on your skin, it is not dangerous. However, avoid oil contact with eyes and nose. If you get oil in your eyes or in your respiratory tract, contact a doctor immediately.
- . Keep explosive and flammable liquids away from sparks and open flames.

Daily inspections

It is important to inspect the equipment daily. If you notice a defect, you must repair it immediately.

- . When under load pressure, worn bolts can provoke a risk of rupture. If cracks are detected on the loader, any operation in progress must be stopped immediately.
- . Damaged hoses must be replaced immediately. Check for leaks. Oil leaks create a risk of accidents and can harm the environment.
- . Check the bolts and tighten the bolts if necessary.
- . Perform the various movement patterns of the loader to verify that all functions are intact and working properly.



Safety Instructions

Greasing points and intervals

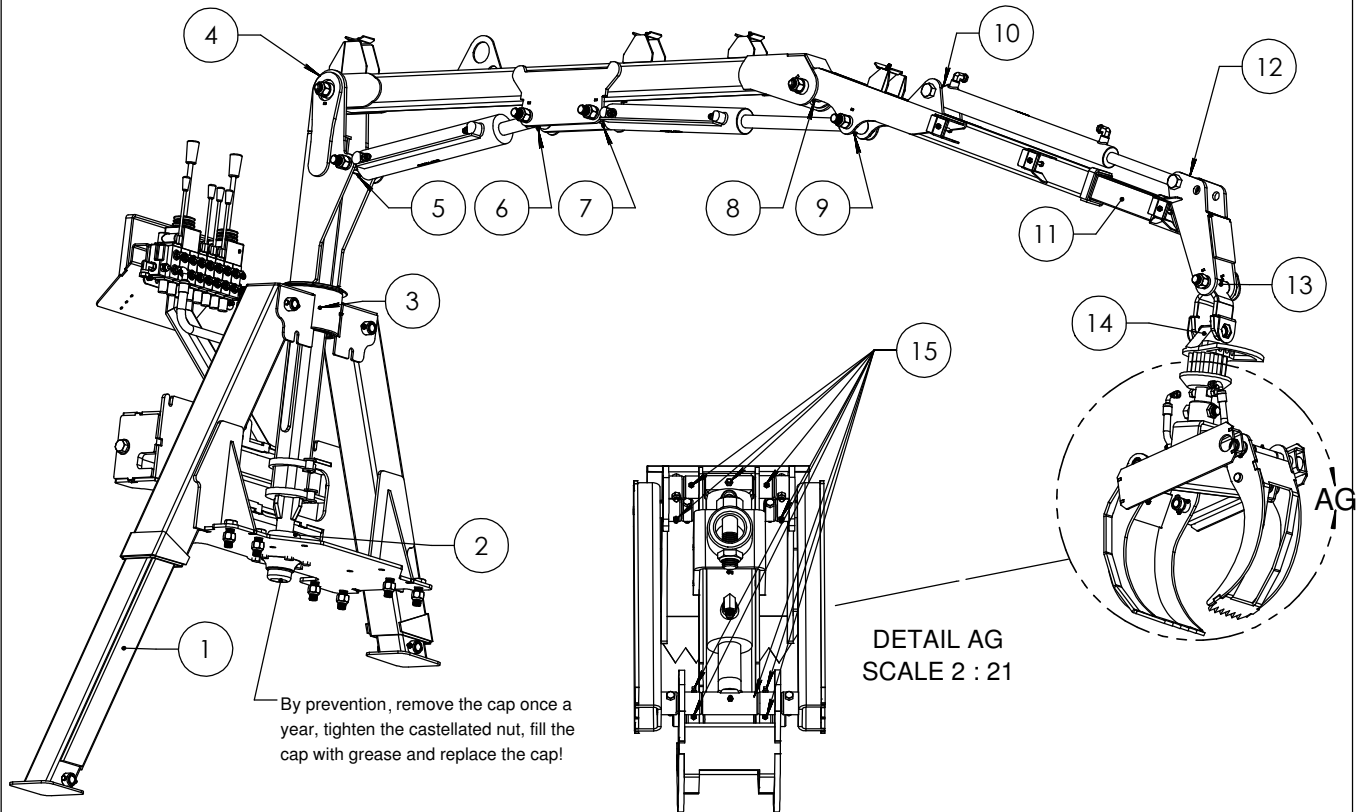

ITEM	Greasing point	Lubricating oil	Greasing Interval hourly / yearly
1	Telescopic stabilizers	Bushing grease	Once a year, generously
2	Hub/bearing	Bearing grease	Every 10 hours
3	Rotation	Bushing grease	Every 10 hours
4	Main boom pin	Bushing grease	Every 10 hours
5	Cylinder pin	Bushing grease	Every 10 hours
6	Cylinder pin	Bushing grease	Every 10 hours
7	Cylinder pin	Bushing grease	Every 10 hours
8	Stick boom pin	Bushing grease	Every 10 hours
9	Cylinder pin	Bushing grease	Every 10 hours
10	Cylinder pin	Bushing grease	Once a year
11	Telescopic boom	Bushing grease	Once a year, generously
12	Cylinder pin	Bushing grease	Once a year
13	Grapple yoke pin	Bushing grease	Every 10 hours
14	Rotator pin	Bushing grease	Every 10 hours
15	Grapple greasing points	Bushing grease	Every 5 hours

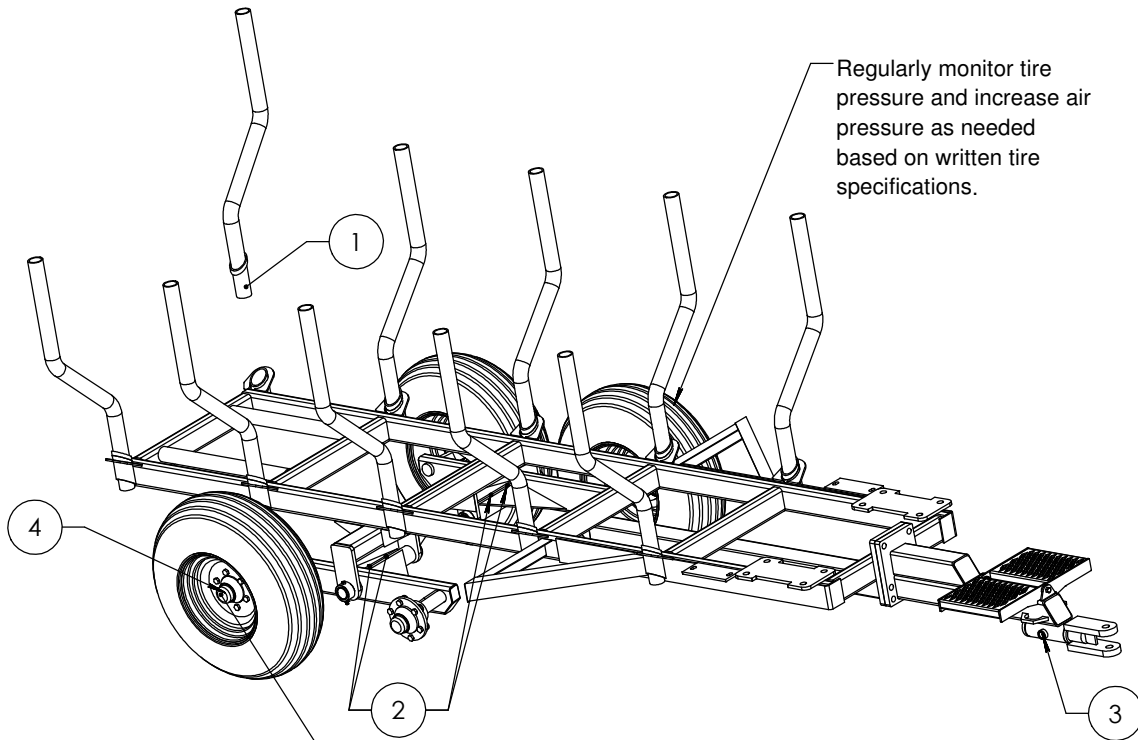

By prevention, remove the cap once a year, tighten the castellated nut, fill the cap with grease and replace the cap!

Item	Greasing point	Lubricating oil	Greasing Interval hourly / yearly
1	Posts	Bushing grease	Once a year, generously
2	Tandem pin	Bushing grease	10 hours
3	Hitch pin	Bushing grease	10 hours
4	Hub/bearing	Bearing grease	50 hours



Maintenance and safety instructions for proper use of the 6000 lb. hydraulic winch

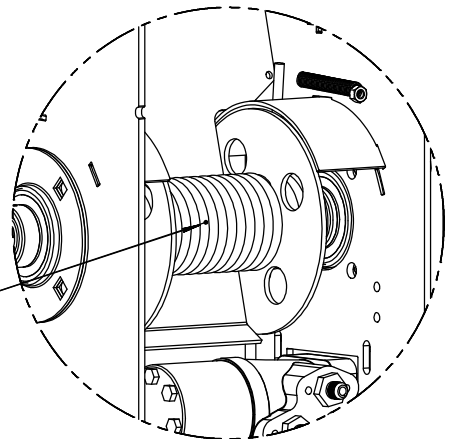
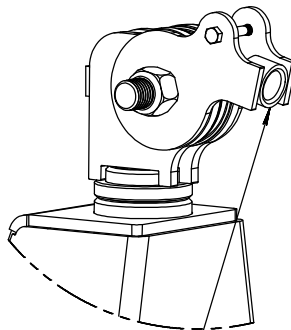
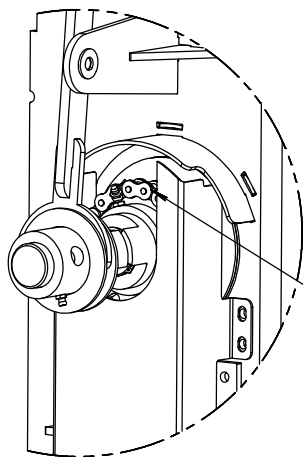
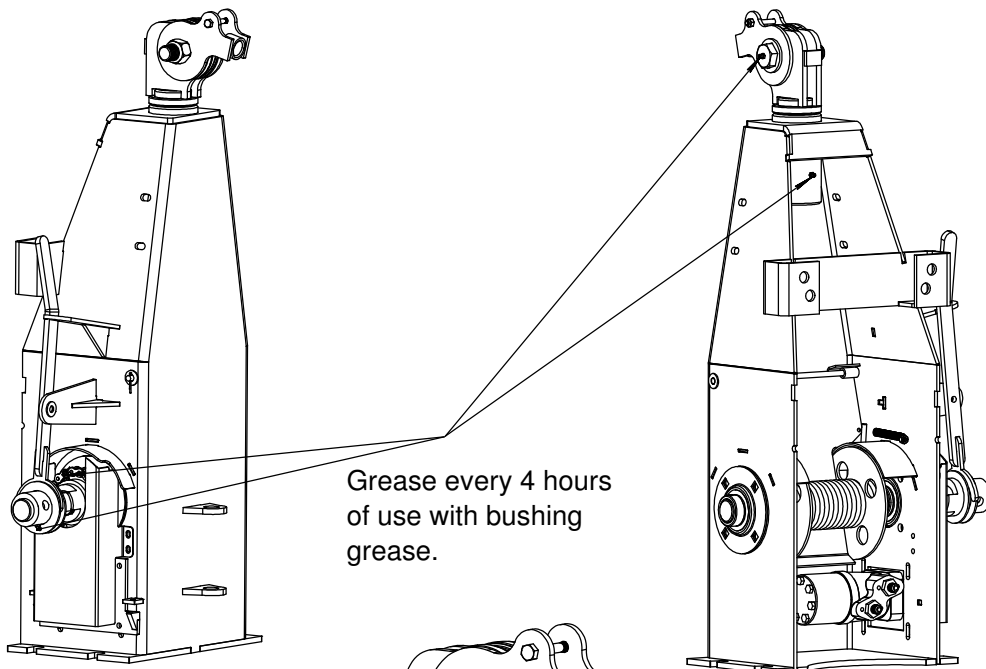

Caution: Risk of crushing your finger or hand and could even lead to death!!!



Maintenance and safety instructions for proper use of a single drawbar (Image for illustrative purposes only)

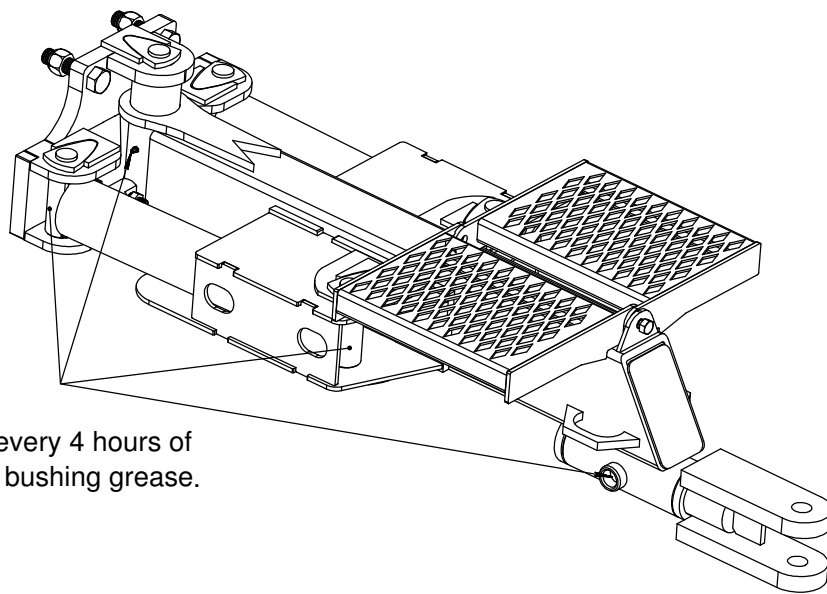

Grease every 4 hours of
use with bushing grease.

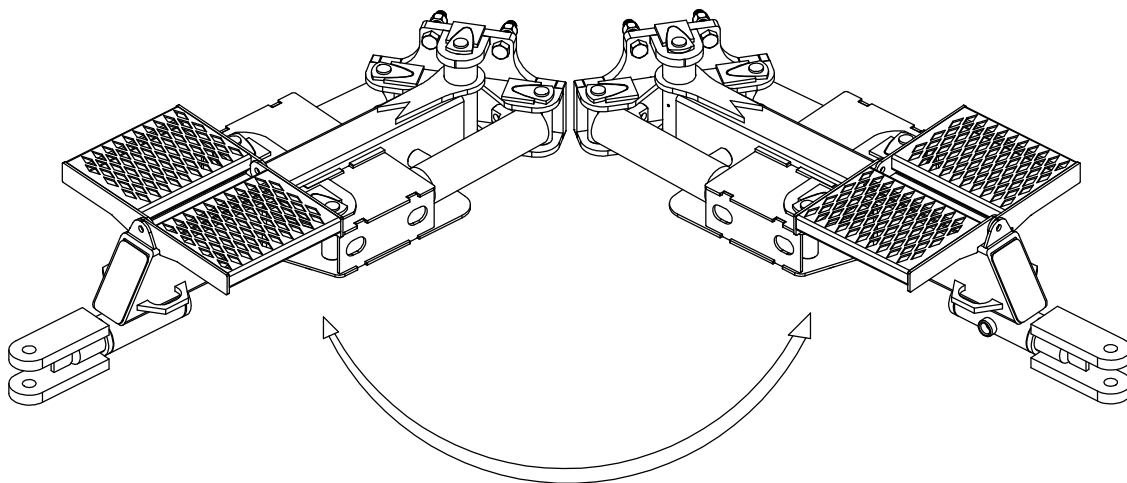

Make sure that no one is standing in
the perimeter and also make sure no
one is standing on the step!



Storage

If you plan to stop using the loader for a long period of time, it should be cleaned carefully. Note that high pressure cleaning is not recommended! After cleaning, make a visual inspection for any cracks (if you find any, you must have them repaired before the next use of the loader) all grease nipples must be lubricated. The grease is used to evacuate water and thus neutralize corrosion and wear.

- . Store the loader under a roof. If this is not possible, cover it with a tarpaulin.
- . Place loader boom and grapple in the transport position.

Note: A stored loader is not a play area for children.