



ROTARY CUTTERS

MODEL: TC07-40

MODEL: TC10-400/TC10-500/TC10-600

MODEL: TC94-40/TC94-400/TC94-500/TC94-600

MODEL: TC94-500MC/TC94-600MC/TC94-700MC

OPERATOR'S MANUAL AND PARTS BOOK

OPERATOR'S MANUAL PART# 60-2007



Tebben Enterprises - 10009 Highway 7 SE - Clara City, Minnesota 56222

Phone: (320)847-2200

ATTENTION

GEARBOX DOES NOT CONTAIN OIL LUBRICANT !

FILL GEARBOX TO THE PROPER LEVEL WITH 80 TO 90 WEIGHT GEAR LUBRICANT OR EQUIVALENT FOR ALL OPERATING CONDITIONS; BEFORE USING ROTARY CUTTER.

GEARBOX DOES NOT CONTAIN OIL LUBRICANT !

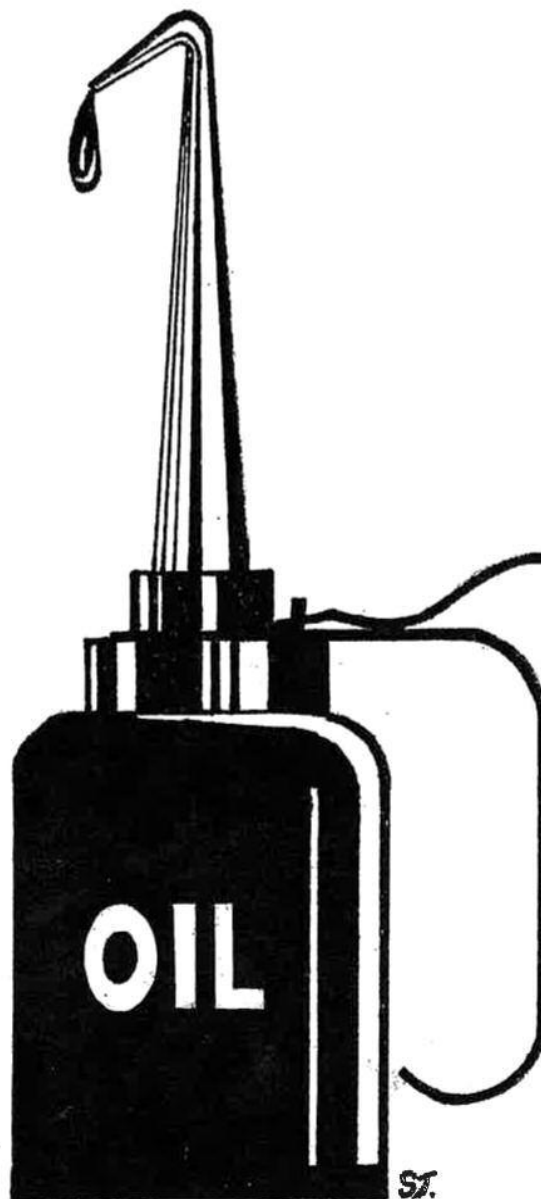

SERIAL NUMBER LOCATION

Always give your dealer the serial number of your Tebben Rotary Cutter when ordering parts or requesting service or other information.

The serial number plate is located where indicated. Please mark the number in the space provided for easy reference.

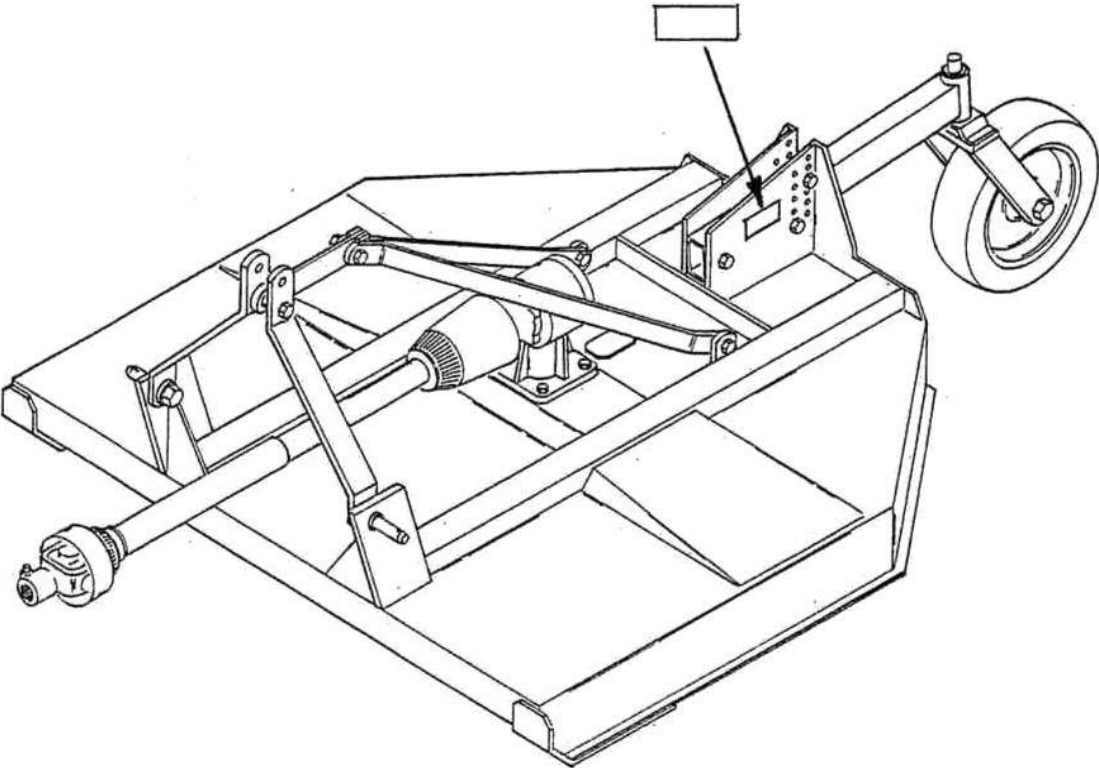

Model Number _____

Serial Number _____

WARRANTY

Tebben Enterprises of Clara City, Minnesota 56222, warrants that its products and their components will be free from defects in material and workmanship for a period of one (1) year from the date of original purchase when used as intended and under normal service and conditions. This warranty is limited to the replacement of any defective part by **Tebben Enterprises**, provided that any such defective part must be returned to **Tebben Enterprises**, TRANSPORTATION PREPAID, accompanied by a letter setting forth the nature of the defect. If the part is found to be defective by reason of materials or workmanship, **Tebben Enterprises**, shall replace the part, but shall not be responsible for its re-installation.

This warranty does not cover or apply to any products or component parts which have been tampered with, modified or altered in any way or which have been subject to misuse, negligence, involved in an accident, or damaged by and act of God.

EXCLUSION OF WARRANTIES

TEBBEN ENTERPRISES MAKES NO WARRANTIES OF MERCHANTABILITY OR FITNESS FOR ANY PARTICULAR PURPOSE IN RESPECT TO ITS PRODUCTS OR COMPONENT PARTS. TEBBEN ENTERPRISES SHALL NOT BE LIABLE FOR ANY CONSEQUENTIAL OR INCIDENTAL DAMAGES FROM ANY BREACH OF WARRANTY, INCLUDING, BUT NOT LIMITED TO, LOSS OF PROFITS, INCONVENIENCE, AND THE COST OF RENTAL OR REPLACEMENT EQUIPMENT. NO AGENT, EMPLOYEE OR REPRESENTATIVE OF TEBBEN ENTERPRISES HAS THE AUTHORITY TO BIND IT TO ANY AFFIRMATION, STATEMENT OF WARRANTY CONCERNING ITS PRODUCTS AND THEIR COMPONENT PARTS EXCEPT AS SPECIFICALLY SET FORTH HEREIN.





	<p data-bbox="783 1671 839 1720"></p> <p data-bbox="887 1664 1118 1709">WARNING</p> <p data-bbox="751 1753 1102 1776">To prevent serious injury or Death</p> <ul data-bbox="751 1780 1142 1928" style="list-style-type: none"><li data-bbox="751 1780 1142 1803">•Avoid unsafe operation or maintenance.<li data-bbox="751 1807 1142 1877">•Do not operate or work on this machine without reading and understanding the operators manual.<li data-bbox="751 1881 1142 1928">•If manual is lost, contact your nearest dealer for a new manual.
---	---

TABLE OF CONTENTS

DESCRIPTION	PAGE
INTRODUCTION	1
SAFETY	2
General Safety	3
Operating Safety	4
Maintenance Safety	4
Transport Safety	5
Storage Safety	5
Safety Decals	5
Sign-Off Form	6
SAFETY DECAL LOCATIONS	7-8
OPERATION	9
To The New Operator or Owner	9
Machine Components	10
Machine Break-In	11
Pre-Operation Checklist	11
Equipment Matching	12
Attaching/Unhooking	13
Field Operation	14-16
Transporting	17-18
Storage	19
SERVICE AND MAINTENANCE	20
Fluids and Lubricants	20
Greasing	20
Servicing Intervals	21
Service Record	21
Maintenance	22
Trailing Wheel Height	22
Shear Pin	22
Blade Replacement	23
Driveline Maintenance	24
Gearbox Maintenance	24
Optional Slip Clutch Maintenance	25
TROUBLE SHOOTING	26
ASSEMBLY	27
OPTIONS	28
Chain Guard Deflectors	28
Slip Clutch (Light Duty)	28
SPECIFICATIONS	29
Bolt Torque	30
PARTS LIST	31
Rotary Cutter (Roundback)	32-33
Rotary Cutter (Economy)	34-35
Rotary Cutter (Medium Duty)	36-37
Rotary Cutter (Heavy Duty)	38-39
Optional Pull Type Hitch	40-41
Gearbox (Roundback, Economy, & Medium Duty)	42-43
Gearbox (Heavy Duty)	44-45
Driveline (Roundback, Economy & Medium Duty)	46-49
Driveline (Heavy Duty)	50-51

INTRODUCTION

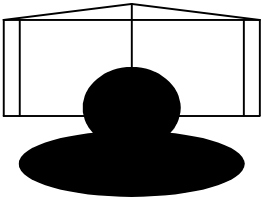
Congratulations on your choice of a Tebben Rotary Cutter to complement your mowing operation. This equipment has been designed and manufactured to meet the needs of a discriminating buyer for the efficient cutting of grass.

Safe, efficient and trouble free operation of your Rotary Cutter requires that you and anyone else who will be operating or maintaining the machine, read and understand the Safety, Operation, Maintenance and Trouble Shooting information contained within the Operator's Manual.



This manual covers the Tebben Rotary Cutter Models TC94-400, TC94-500, TC94-600, TC94-500MC, TC94-600MC, TC94-700MC, TC07-40, TC07-400, TC07-500, TC07-600, TC10-400, TC10-500, & TC10-600. Differences are covered and explained where appropriate. Use the Table of Contents as a guide to locate required information.

Keep this manual handy for frequent reference and to pass on to new operator or owners. Call your Tebben dealer or distributor if you need assistance, information or additional copies of the manuals.

OPERATOR ORIENTATION - The directions left, right, front and rear, as mentioned throughout this manual, are as seen from the driver's seat and facing in the direction of travel.

SAFETY

SAFETY ALERT SYMBOL

This Safety Alert symbol means
ATTENTION! BECOME ALERT!
YOUR SAFETY IS INVOLVED!

The Safety Alert symbol identifies important safety messages on the Tebben Rotary Cutter and in the manual. When you see this symbol, be alert to the possibility of personal injury or death. Follow the instructions in the safety message.



Why is **SAFETY** important to you?

3 BIG REASONS

Accidents Disable and Kill
Accidents Cost
Accidents Can Be Avoided

SIGNAL WORDS:

Note the use of the signal words **DANGER**, **WARNING** and **CAUTION** with the safety messages. The appropriate signal word for each message has been selected using the following guide lines:

DANGER - An immediate and specific hazard which **WILL** result in severe personal injury or death if the proper precautions are not taken.

WARNING - A specific hazard or unsafe practice which **COULD** result in severe personal injury or death if proper precautions are not taken.

CAUTION - Unsafe practices which **COULD** result in personal injury if proper practices are not taken, or as a reminder of good safety practices.

SAFETY

YOU are responsible for the **SAFE** operation and maintenance of your Tebben Rotary Cutter. **YOU** must ensure that you and anyone else who is going to operate, maintain or work around the Cutter be familiar with the operating and maintenance procedures and related **SAFETY** information contained in this manual. This manual will take you step-by-step through your working day and alerts you to all good safety practices that should be followed while operating your Rotary Cutter.

Remember, **YOU** are the key to safety. Good safety practices not only protect you but also the people around you. Make these practices a working part of your safety program. Be certain that **EVERYONE** operating this equipment is familiar with the recommended operating and maintenance procedures and follows all the safety precautions. Most accidents can be prevented. Do not risk injury or death by ignoring good safety practices.

- Rotary Cutter owners must give operating instructions to operators or employees before allowing them to operate the Cutter, and at least annually thereafter per OSHA (Occupational Safety and Health Administration) regulation 1928.57.
- The most important safety device on this equipment is a **SAFE** operator. It is the operator's responsibility to read and understand **ALL** Safety and Operating instructions in the manual and to follow these. All accidents can be avoided.
- In addition to the design and configuration of equipment, hazard control and accident prevention are dependant upon the awareness, concern, prudence and proper training of personnel involved in the operation, transport, maintenance and storage of equipment. Train all new personnel and review instructions frequently with existing workers. A person who has not read and understood all operating and safety instructions is not qualified to operate the machine. An untrained operator exposes himself and bystanders to possible serious injury or death.
- Do not modify the equipment in any way. Unauthorized modification may impair the function and/or safety and could affect the life of the equipment.
- Think **SAFETY!** Work **SAFELY!**

GENERAL SAFETY

1. Read and understand the Operator's Manual and all safety signs before operating, maintaining, adjusting or unplugging the Cutter. 
2. Have a first-aid kit available for use should the need arise and know how to use it. 
3. Have a fire extinguisher available for use should the need arise and know how to use it. 
4. Wear appropriate protective gear. This list includes but is not limited to:
 - A hard hat
 - Protective shoes with slip resistant soles
 - Protective goggles, glasses or face shield
 - Heavy gloves
 - Protective Clothing
5. Install and secure all guards before starting.
6. Do not allow riders. 
7. Wear Suitable ear protection for prolonged exposure to excessive noise.
8. Place all controls in neutral, stop tractor engine, set park brake, remove ignition key and wait for all moving parts to stop before servicing, adjusting, repairing or unplugging.
9. Clear the area of people, especially small children, before starting the unit.
10. Review safety related items annually with all personnel who will be operating or maintaining the Cutter.

OPERATING SAFETY

1. Read and understand the Operators Manual and all safety signs before operating, servicing, adjusting, repairing or unplugging.
2. **DO NOT** allow riders.
3. Install and secure all guards and shields before starting or operating.
4. Keep hands, feet, hair and clothing away from moving parts.
5. Place all controls in neutral, stop tractor engine, set park brake, remove ignition key and wait for all moving parts to stop before servicing, adjusting, repairing or unplugging.
6. Place all tractor and machine controls in neutral before starting.
7. **NEVER** start operate machine unless sitting on tractor seat.
8. Clear the area of bystanders, especially small children, before starting.
9. Stay away from PTO shaft and machine when engaging PTO. Keep others away.
10. Clean reflectors, SMV and lights before transporting.
11. Use hazard flashers on tractor when transporting.
12. **DO NOT** put hands or feet under machine while tractor engine or machine is running.
13. **DO NOT** Operate Cutter in the raised position.
14. Objects can be thrown out from under machine with sufficient force to severely injure people. Stay away from machine when it is running. Keep others away.
15. Chain guard deflectors are recommended during operation.
16. Always know what you are cutting. Never operate Cutter in an area that has hidden obstacles. Remove sticks, stones, wire or other objects from working area before starting.
17. Review safety instructions with all operators annually.

MAINTENANCE SAFETY

1. Follow **ALL** the operating, maintenance and safety information in the manual.
2. Support the machine with blocks or safety stands when working beneath it.
3. Follow good shop practices
 - Keep service area clean and dry.
 - Be sure electrical outlets and tools are properly grounded.
 - Use adequate light for the job at hand.
4. Use only tools, jacks and hoists of sufficient capacity for the job.
5. **NEVER** work on blades or under the machine unless the tractor engine is off and driveline is disconnected.
6. Wear heavy canvas or leather gloves when handling sharp blades.
7. Make sure all guards are in place and properly secured when maintenance work is completed.
8. **NEVER** wear ill-fitting, baggy or frayed clothing when working around or on and of the drive system components.
9. Keep hands, feet, hair and clothing away from moving or rotating parts.
10. Clear the area of bystanders, especially small children, when carrying out any maintenance and repairs or making any adjustments.



TRANSPORT SAFETY

1. Make sure you are in compliance with all local regulations regarding transporting equipment on public roads and highways.
2. Make sure the SMV (Slow Moving Vehicle) emblem and all the lights and reflectors that are required by the local highway and transport authorities are in place, are clean and can be seen clearly by all overtaking and oncoming traffic.
3. **DO NOT** allow anyone to ride on the CUTTER or tractor during transport.
4. **DO NOT** exceed 20 mph (32 kph). Reduce speed on rough roads and surfaces.
5. Use retainers on the mounting pins when attaching.
6. **ALWAYS** use hazard flashers on the tractor when transporting unless prohibited by law.

STORAGE SAFETY

1. Store the unit in an area away from human activity.
2. **DO NOT** permit children to play on or around the stored machine.
3. Store the unit in a dry, level area. Support the frame with planks if required.

SAFETY DECALS

1. Keep safety decals and sign clean and legible at all times.
2. Replace safety decals and signs that are missing or have become illegible.
3. Replaced parts that displayed a safety sign should also display the current sign.
4. Safety decals or signs are available from your dealer parts department or the manufacturer.

How to Install Safety Decals:

- Be sure that the installation area is clean and dry.
- Decide on the exact position before you remove the backing paper.
- Remove the smallest portion of the split backing paper.
- Align the decal over the specified area and carefully press the small portion with the exposed sticky backing in place.
- Slowly peel back the remaining paper and carefully smooth the remaining portion of the decal in place.
- Small air pockets can be pierced with a pin and smoothed out using the piece of decal backing paper.

SAFETY DECAL LOCATIONS

The types of decals and locations on the equipment are shown in the illustration below. Good Safety requires that you familiarize yourself with the various Safety Decals, the type of warning and the area, or particular function related to that area, that requires your SAFETY AWARENESS.

* **Think SAFETY! Work SAFELY!**

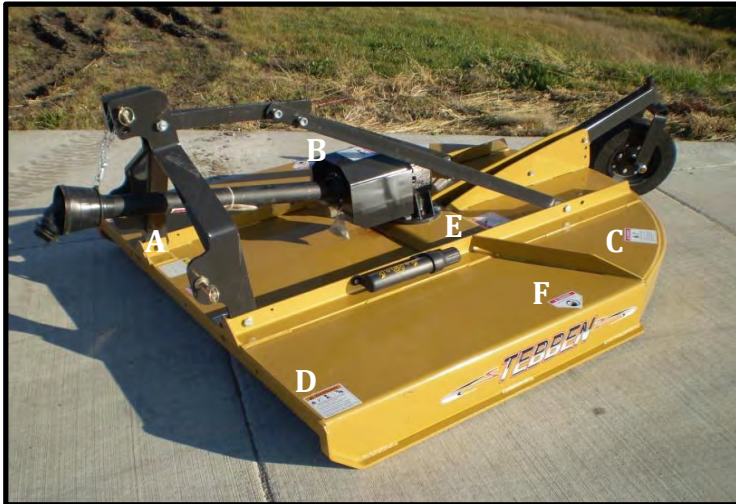

PART NO. 60-99



PART NO. 60-97



PART NO. 60-98



REMEMBER - If Safety Decals have been damaged, removed, become illegible or parts replaced without decals, new decals must be applied. New decals are available from your authorized dealer.

The types of decals and locations on the equipment are shown in the illustration below. Good safety requires that you familiarize yourself with the various Safety Decals, the types of warning and the area, or particular function related to that area, that requires your SAFETY AWARENESS.

* **Think SAFETY! Work SAFELY!**

PART NO. 60-96



PART NO. 60-95



PART NO. 48-106



PART NO. 60-1000



REMEMBER - If Safety Decals have been damaged, removed, become illegible or parts replaced without decals, new decals must be applied. New decals are available from your authorized dealer.

OPERATION



OPERATING SAFETY

1. Read and understand the Operator's Manual and all safety signs before operating, servicing, adjusting, repairing or unplugging.
2. Do not allow riders.
3. Install and secure all guards and shields before starting or operating.
4. Keep hands, feet, hair and clothing away from moving parts.
5. Place all controls in neutral, stop tractor engine, set park brake, remove ignition key and wait for all moving parts to stop before servicing, adjusting, repairing, or unplugging.
6. Place all tractor and machine controls in neutral before starting.
7. Never start or operate machine unless sitting on tractor seat.
8. Clear the area of bystanders, especially small children, before starting.
9. Stay away from PTO shaft and machine when engaging PTO. Keep others away.
10. Clean reflectors, SMV and lights before transporting.
11. Use hazard flashers on tractor when transporting.
12. Do not put hands and feet under machine while tractor engine or machine is running.
13. Do not operate Cutter in raised position.
14. Objects can be thrown out from under machine with sufficient force to severely injure people. Stay away from machine when it is running. Keep others away.
15. Operate only with chain guard deflectors installed.
16. Always know what you are cutting. Never operate cutter in an area that has hidden obstacles. Remove sticks, stones, wire or other objects from working area before starting.
17. Review safety instructions with all operators annually.

TO THE NEW OPERATOR OR OWNER

The Tebben Implement Rotary Cutter is designed to cut a variety of grasses and other ground covers. Rotational power to the blades is provided by the tractor PTO. Be familiar with the machine before starting.

In addition to the design and configuration of equipment, hazard control and accident prevention are dependant upon the awareness, concern, prudence and proper training of personnel involved in the operation, transport, maintenance and storage of equipment. It is the responsibility of the owner or operator to read this manual and to train all other operators before they start working with the machine. Follow all safety instructions exactly. Safety is everyones business. By following recommended procedures, a safe working environment is provided for the operator, bystanders and the area around the worksite. Untrained operators are not qualified to operate the machine. Many features incorporated into this machine are the result of suggestions made by customers ilke you. Read this manual carefully to learn how to operate the machine safely and how to set it to provide maximum field efficiency. By following the operating instructions in conjunction with a good maintenance program, your Cutter will provide many years of trouble-free service.

MACHINE COMPONENTS

The Tebben Rotary Cutter consists of a large rotating plate that has free-swinging steel blades attached to it. The blades cut the grass while traveling over the working area. Rotational power to the plate is provided by the tractor PTO through a gear box in the center of the machine. An access cover on the deck provides the operator with access to the blade bolts. The Rotary Cutter attaches to the 3 point hitch on the tractor.

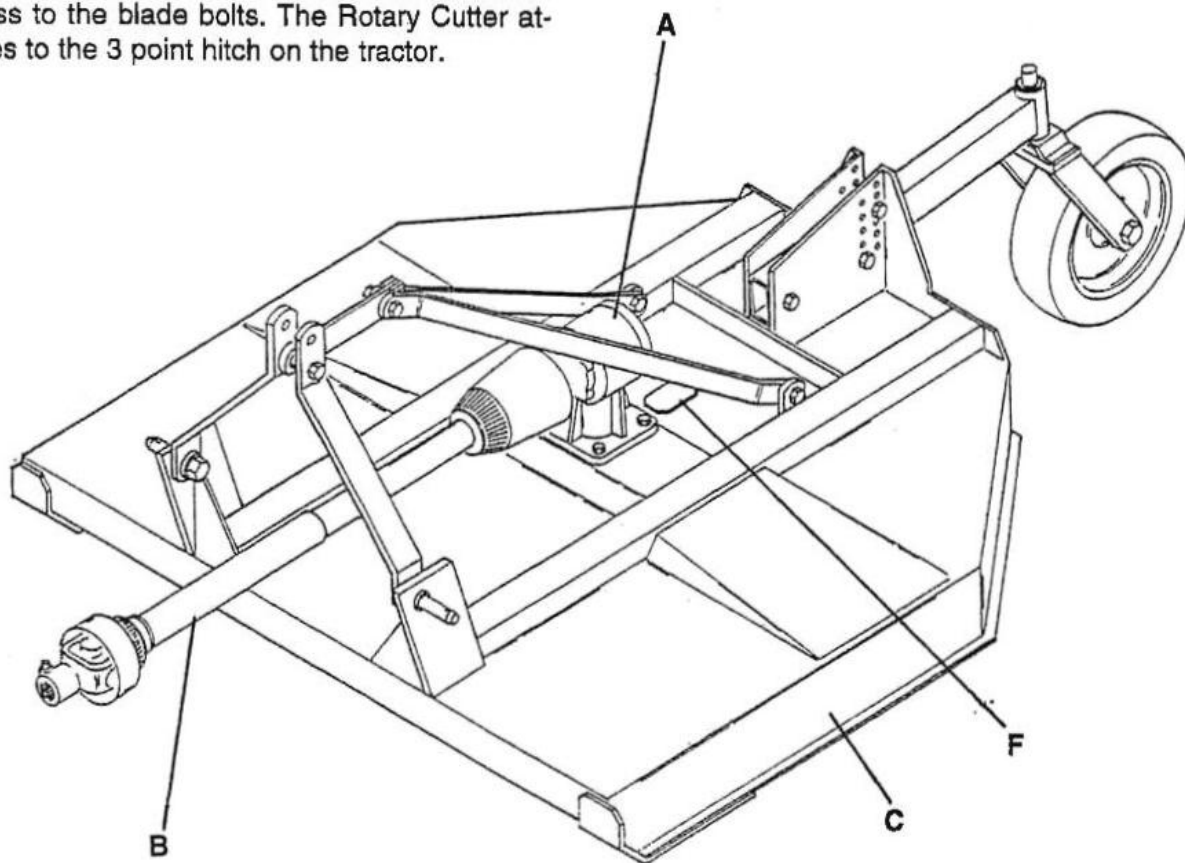

- A Gear Box
- B Driveline
- C Deck
- D Stump Deflector Plate
- E Blades
- F Access Cover

MACHINE COMPONENTS

MACHINE BREAK-IN

Although there are no operational restrictions on the Rotary Cutter when used for the first time, it is recommended that the following mechanical items be checked:

- A. After operating for 1/2 hour or after completing 2 acres:
 - 1. Check all nuts, bolts and other fasteners. Tighten to their specified torque levels.
 - 2. Tighten blade bolts to their specified torque levels.
 - 3. Check that the blades are in good condition and swing freely.
 - 4. Check the oil level in the gear box. Add as required.
 - 5. Check that the PTO driveline shield turns freely.
 - 6. Lubricate all grease points.
- B. After operating for 5 hours and 10 hours:
 - 1. Repeat items 1 through 5 of section A.
 - 2. Then go to the regular service schedule.

PRE-OPERATION CHECKLIST

Efficient and safe operation of the Tebben Rotary Cutter requires that each operator reads and understands the operating procedures and all related safety precautions outlined in this section. A pre-operation checklist is provided for the operator. It is important for both the personal safety and maintaining the good mechanical condition of the Rotary Cutter that this checklist is followed.

Before operating the machine and each time thereafter, the following areas should be checked off:

- 1. Lubricate the machine per the schedule outlined in Section 5 Service and Maintenance.
- 2. Use only an Agricultural tractor of horsepower within the limits of the machine specified in Table 1.
- 3. Check that the machine is properly attached to the tractor. Be sure retainers are used on the mounting pins.
- 4. Be sure extra weights are mounted on the front of the tractor.
- 5. Check the oil level in the gear box. Add as required.
- 6. Check that the PTO driveline turns freely and that the driveline can telescope easily.
- 7. Check the blades. Be sure they are not damaged or broken and swing freely on their mount. Repair or replace as required.
- 8. Check the blade bolts. Tighten to their specified torque.
- 9. Check for entangled material in all rotating parts. Remove this material.
- 10. Install and secure all guards, doors and covers before starting.

Table 1 Horsepower vs Width

Model	Width	Horsepower
TC94-400	48"	30
TC94-500	60"	40
TC94-600	72"	40

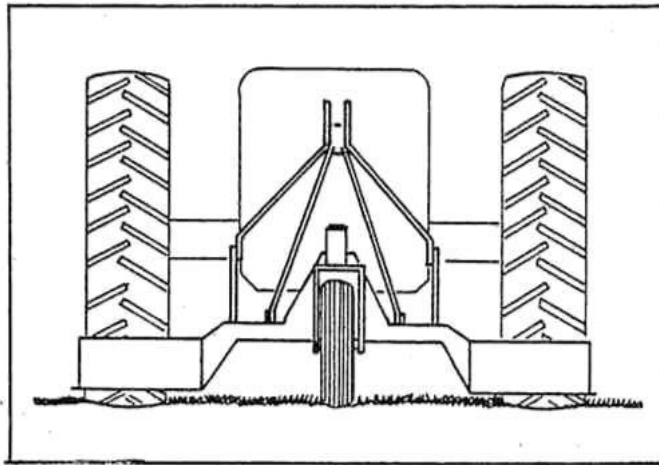

TIRE CONFIGURATION

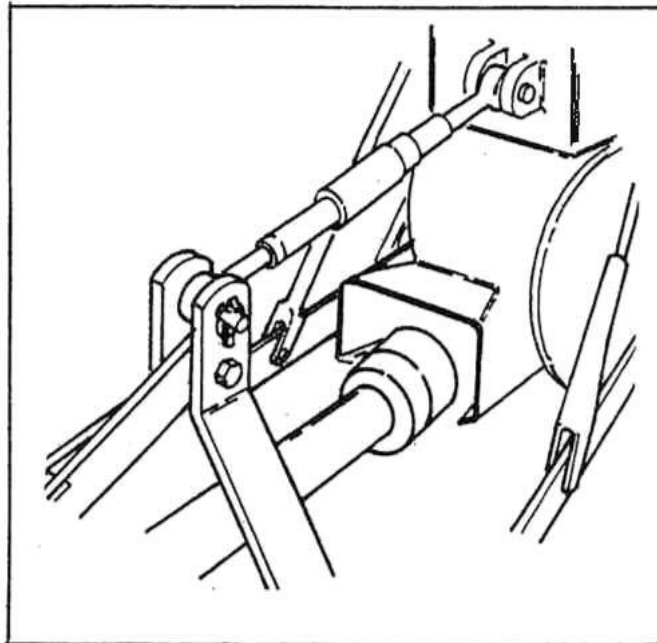

3 POINT HITCH

ATTACHING/UNHOOKING

The Cutter should always be located on a level, dry area that is free of debris and other foreign objects. When attaching the machine to a tractor, follow this procedure.

1. Clear the area of bystanders, especially small children.
2. Be sure the tractor 3 point hitch is in the Category 1 configuration and the lift arms are in the non-sway configuration (see tractor manual).
3. Be sure that weights are added on the front of the tractor.
4. Make sure there is enough room and clearance to safely back up to the machine.
5. Attach the PTO driveline to the cutter if it was removed for storage (See Assembly).
6. While backing up, align the lift arm balls with the mounting pins on the Cutter.

NOTE

It may be necessary to add weight to the 3 point hitch to lower the lift arms.

7. Stop tractor, set park brake, remove ignition key and wait for all moving parts to stop before dismounting.
8. Align the left lower link arm with the mounting pin.
9. Slide the ball over the pin and install the retainer.
10. Use the screw jack on the right lift arm to align the ball with the pin.
11. Slide the ball over the mounting pin and install the retainer.
12. Level the frame and lift arms using a screw jack.
13. Remove retainer and pin from the mast.
14. Align top link using the turnbuckle.
15. Insert pin and install retainer.
16. Set the mast using the turnbuckle to place the mounting pin in the center of its slot.
17. Attach the PTO driveline:
 - a. Check that the driveline telescopes easily and that the shield rotates freely.
18. Use the 3 point hitch to raise the machine.
19. Reverse the above procedure when unhooking from the tractor.

IMPORTANT

Be sure that the driveline does not bottom out when going through its working angles

- b. Attach the driveline to the tractor by retracting the locking pin, slide the yoke over the shaft and push on the yoke until the lock pin clicks into position. Pull on the yoke to be sure it is locked in position.

FIELD OPERATION



OPERATING SAFETY

1. Read and understand the Operator's Manual and all safety signs before operating, servicing, adjusting, repairing or unplugging.
2. Do not allow riders.
3. Install and secure all guards and shields before starting or operating.
4. Keep hands, feet, hair and clothing away from moving parts.
5. Place all controls in neutral, stop tractor engine, set park brake, remove ignition key and wait for all moving parts to stop before servicing, adjusting, repairing or unplugging.
6. Place all tractor and machine controls in neutral before starting.
7. Never start or operate machine unless sitting on tractor seat.
8. Clear the area of bystanders, especially small children, before starting.
9. Stay away from PTO shaft and machine when engaging PTO. Keep others away.
10. Clean reflectors, SMV and lights before transporting.
11. Use hazard flashers on tractor when transporting.
12. Do not put hands or feet under machine while tractor engine or machine is running.
13. Do not operate Cutter in the raised position.
14. Objects can be thrown out from under machine with sufficient force to severely injure people. Stay away from machine when it is running. Keep others away.
15. Operate only with chain guard deflectors installed.
16. Always know what you are cutting. Never operate cutter in an area that has hidden obstacles. Remove sticks, stones, wire or other objects from working area before starting.
17. Review safety instructions with all operators annually.

Rotary Cutters are designed with the inherent flexibility of operating well in almost any kind of grass and terrain conditions. However the operator has the responsibility of being familiar with all operating and safety procedures and following them.

In addition to the design and configuration of equipment, hazard control and accident prevention are dependent upon the awareness, concern, prudence and proper training of personnel involved in the operation, transport, maintenance and storage of equipment. Each operator should review this section of the manual at the start of the season and as often as required to be familiar with

the machine. When using, follow this procedure:

1. Review and follow the Pre-Operation Checklist.
2. Attach the tractor to the machine.
3. Before going to the cutting area review transporting.
4. Pull into the field and stop in a level area.
5. Lower into working position.

6. Set the Machine

a. Level the Frame:

Use the screw jack on the right lift arm to level the frame from side-to-side.

Use the turnbuckle on the top link to center the top pin in its slot. This will allow the machine to follow the contour of the ground.

Set the 3 point hitch so deck is 1 to 2 inches (25 to 50 mm) higher at the rear of the deck than the front.

NOTE

It may be necessary to adjust the height of the rear wheel.

b. Height:

Use the adjustment on the trailing wheel to set the height of the deck.

Center hole for normal cutting.

Bottom hole in rough terrain to prevent scalping or when cutting tall or coarse grass.

Top hole in smooth conditions with fine grass.

c. 3 Point Hitch:

Place the 3 point hitch into its "float" operating mode to allow the machine and the hitch to move up and down as required to follow ground contours.

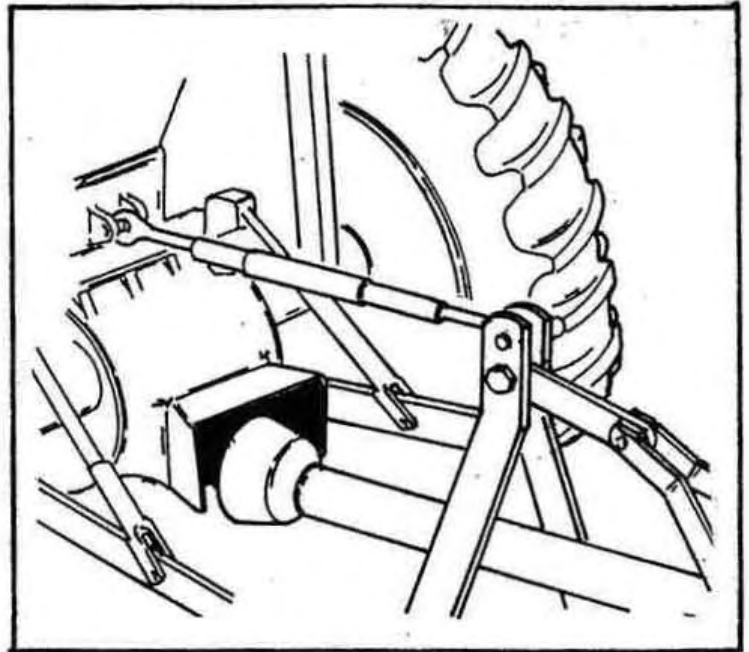

LEVELING ROTARY CUTTER FRAME

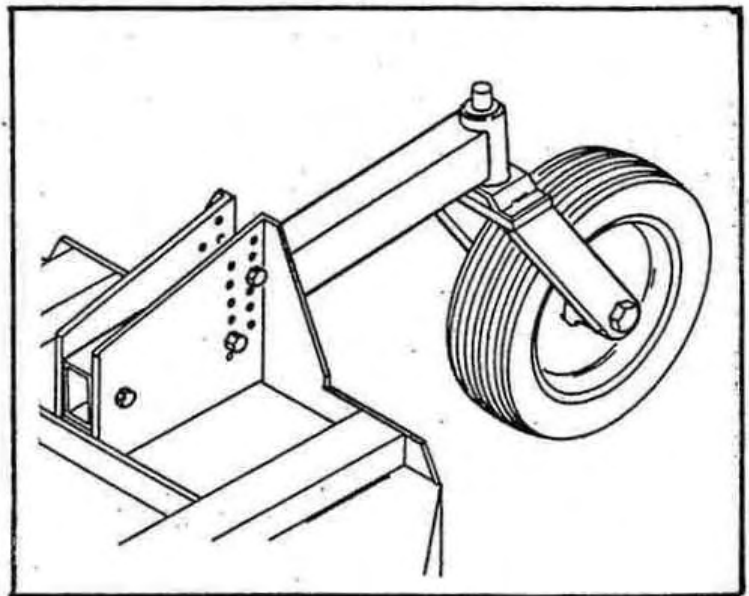

WHEEL HEIGHT

7. Align the unit with the working area.
8. Starting machine:
 - a. Run the engine at low idle.
 - b. Slowly engage the PTO control to start the machine.
 - c. Slowly bring the engine to the rated PTO speed. Never exceed rated speed.
 - d. Lower the machine to the ground and proceed down the field.

9. Stopping machine:
 - a. Slowly decrease engine speed to low idle.

	WARNING
Never operate Cutter in the raised position.	

- b. Disengage PTO clutch slowly.

	CAUTION
Place all controls in neutral, lower machine, stop engine, set park brake, remove ignition key and wait for all moving parts to stop before dismounting.	

10. Ground speed:

Travel speed can vary between 3 and 8 mph (5 and 13 kph) depending on the grass and terrain conditions. It is the responsibility of the operator to note the condition of the job being done and set the speed to obtain a quality cutting job and maintain control of the machine.

The speed can be increased if a good job is being done.

Decrease speed if you are producing a ragged cut or leaving patches uncut.

11. Operating hints:

- a. Although it is best to cut when it is dry, the cutter works well in wet conditions as well. However, the operator will have to travel slower to do the same quality cutting. It will also be necessary to clean the machine more frequently to prevent caking and clogging of the blade area.
- b. The cutter should always be operated at the rated speed of 540 RPM. The cutting action is generated by the speed of the blade tip. When the speed drops below a certain rate (slowing of the input speed or RPM), the blades start to tear the material rather than cut it and will give a "ragged" looking cut.

	CAUTION
Never exceed PTO speed of 540 RPM	

- c. Vary ground speed by changing gears in the tractor transmission rather than changing the throttle setting. Forward travel speeds can range from 3 to 8 MPH (5 to 13 km/h) or more depending on the type of terrain, grass or crop cover length, moisture level and power available. It is the operator's responsibility to determine and operate the machine at a safe speed at all times.
- d. If the crop or grass is tall, cut it twice to obtain the best results. This allows the unit to cut less material on each pass.
- e. When cutting a new area for the first time, always set the mower to cut high to clear unknown obstructions. If none are found, the cutter can be run lower for the second pass.
- f. Never cut grass shorter than recommended for your weather conditions. Short grass is less able to withstand hot and dry conditions. It is better for it to be cut more often at a longer length than to cut it.
- g. The blades will need sharpening when you see that the grass has not been cut evenly or it looks like the grass has been ripped off.

TRANSPORTING



TRANSPORT SAFETY

1. Make sure you are in compliance with all local regulations regarding transporting equipment on public roads and highways.
2. Make sure the SMV (Slow Moving Vehicle) emblem and all the lights and reflectors that are required by the local highway and transport authorities are in place, are clean and can be seen clearly by all overtaking and oncoming traffic.
3. Do not allow anyone to ride on the Cutter or tractor during transport.
4. Do not exceed 20 mph (32 kph). Reduce speed on rough roads and surfaces.
5. Use retainers on the mounting pins when attaching.
6. Always use hazard flashers on the tractor when transporting unless prohibited by law.

9. Always use hazard flashers on the tractor when transporting unless prohibited by law.
10. Use pilot vehicles front and rear when transporting during times of limited visibility.

When transporting the machine, review and follow these instructions:

1. Be sure all bystanders are clear of the machine.
2. Be sure that the machine is securely attached to the tractor and all retainer pins are installed.
3. Be sure you have installed extra weights on the front of the tractor.
4. Clean the SMV emblem, lights and reflectors and be sure they are working.
5. Be sure you are in compliance with all applicable lighting and marking regulations when transporting. Check with your local authorities.
6. Be sure your machine can clearly be seen by overtaking and oncoming traffic.
7. Keep to the right and yield the right-of-way to allow faster traffic to pass. Drive on the road shoulder if permitted by law.
8. Do not allow riders.

h. The dished shape of the rotating plate under the deck acts as a "stump jumper". The concave shape allows the machine to go over stumps, rocks and other obstacles while operating.

i. Always reduce ground speed when cutting around obstructions or in close quarters.

j. The cutter should always be operated with its trailing wheel riding on the ground and not normally lifted for turns or corners unless the ground is very rough or rutted. If lifted, it should be dropped back on the ground as soon as the maneuvering or rough terrain is past.

k. The cutter has two blades under its frame that are turning at a high rate of speed. With this speed, the blades can pick up objects on the ground and discharge them out from under the frame. It is extremely important that the operator be aware that objects can be discharged in this way and never point the discharge areas toward people, animals or property. These discharged objects are propelled at high rate of speed and are moving fast enough to cause serious injury to people, animals and damage to property. It is better to stop cutting when there are bystanders, especially children, than to take the chance of injury.



ROTATING BLADE



WARNING

The rotating blades can pick up objects and expel them at a high rate of speed. These projectiles can be a hazard to people and property. Always keep deflectors in place. Never operate cutter when there are bystanders, especially children around. Use extra care when operating in populated or congested areas.

If people or children approach the working area, stop machine immediately. Do not restart until the working area is cleared.

l. The manufacturer recommends only operating with chain guard deflectors. These deflectors will reduce the amount of debris or number of objects expelled from under the machine.

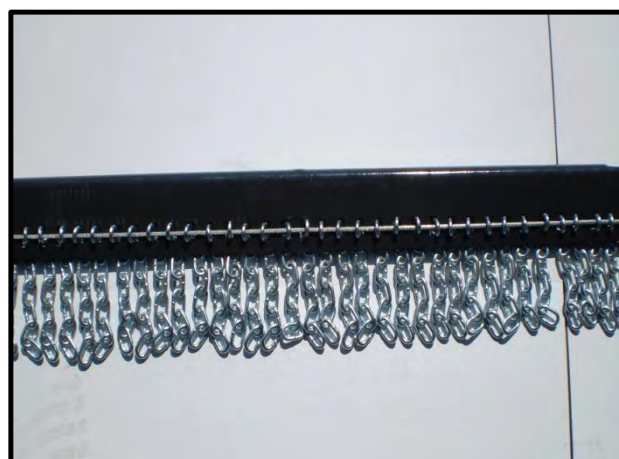

CHAIN GUARD DEFLECTORS

STORAGE



STORAGE SAFETY

1. Store unit in an area away from human activity.
2. Do not permit children to play on or around the stored machine.
3. Store the unit in a dry, level area. Support the frame with planks if required.

After the season's use, the machine should be thoroughly inspected and prepared for storage. Repair or replace any worn or damaged components to prevent any unnecessary down time at the start of next season. To ensure a long, trouble free life, this procedure should be followed when preparing the unit for storage:

1. Clear the area of bystanders, especially small children.
2. Thoroughly wash the machine using a pressure washer to remove all dirt, mud, debris and residue.
3. Inspect the blades and rotor for damage or entangled material. Repair or replace damaged parts. Remove all entangled material.
4. Lubricate all grease fittings. Make sure that all grease cavities have been filled with grease to remove any water residue from the washing.
5. Remove the end of the PTO shaft and store inside.
6. Touch up all paint nicks and scratches to prevent rusting.
7. Move to storage area.
8. Select an area that is dry, level and free of debris.
9. Unhook from tractor.
10. If the machine cannot be placed inside, cover with waterproof tarpaulin and tie securely in place.
11. Store the machine in an area away from human activity.
12. Do not allow children to play on or around the stored machine.

SERVICE AND MAINTENANCE



MAINTENANCE SAFETY

1. Follow ALL the operating, maintenance and safety information in the manual.
2. Support the machine with blocks or safety stands when working beneath it.
3. Follow good shop practices
 - Keep service area clean and dry.
 - Be sure electrical outlets and tools are properly grounded.
 - Use adequate light for the job at hand.
4. Use only tools, jacks and hoists of sufficient capacity for the job.
5. Never work on blades or under the machine unless the tractor engine is off and driveline is disconnected.
6. Wear heavy canvas or leather gloves when handling sharp blades.
7. Make sure all guards are in place and properly secured when maintenance work is completed.
8. Never wear ill-fitting, baggy or frayed clothing when working around or on any of the drive system components.
9. Keep hands, feet, hair and clothing away from moving or rotating parts.
10. Clear the area of bystanders, especially small children, when carrying out any maintenance and repairs or making any adjustments.

FLUIDS AND LUBRICANTS

1. Grease:
Use an SAE multi-purpose high temperature grease with extreme pressure (EP) performance. Also acceptable is an SAE multi-purpose lithium base grease.
2. **Gear Box Oil**
Use 80W-90 gear lube of equivalent for all operating conditions.
3. Storing lubricants
Your machine can operate at top efficiency only if clean lubricants are used. Use clean containers to handle all lubricants. Store them in an area protected from dust, moisture and other contaminants.

GREASING

Use the Maintenance Checklist provided to keep a record of all scheduled maintenance.

1. Use a hand-held grease gun for all greasing.
2. Wipe grease fitting with a clean cloth before greasing, to avoid injecting dirt and grit.
3. Replace and repair broken fittings immediately.
4. If fittings will not take grease, remove and clean thoroughly. Also clean lubricant passageway. Replace any fitting if necessary.

MAINTENANCE

By following a careful service and maintenance program for your machine, you will enjoy many years of trouble-free operation.

TRAILING WHEEL HEIGHT

When setting the height of the trailing wheel, follow this procedure:

1. Clear the area of bystanders especially small children.
2. Raise the 3 point hitch or lift with a hoist until the trailing wheel is slightly off the ground.
3. Stop engine, set park brake, remove ignition key and wait for all moving parts to stop before dismounting.
4. Place large blocks or safety stands under the deck to support the machine.
5. Remove the bolt through the trailing wheel support bracket.
6. Install the bolt through the hole to give the desired machine height.
7. Tighten the bolt to its specified torque.
8. Remove the blocks or safety stands.

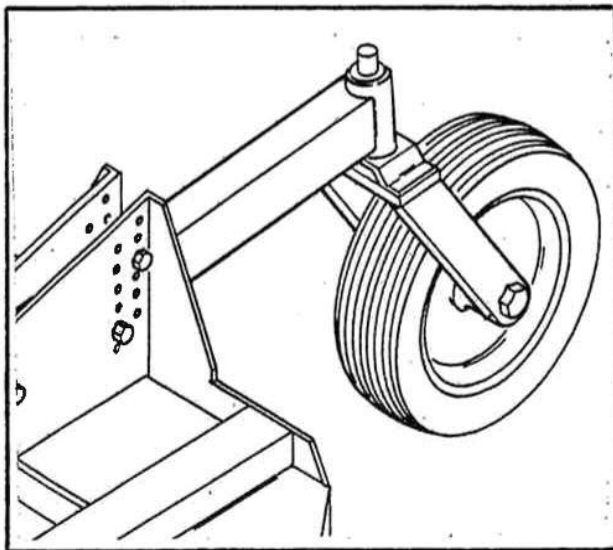

TRAILING WHEEL

SHEAR PIN

A shear pin is located on the gear box input shaft to prevent overloading the drivetrain.

To replace the shear pin, follow this procedure:

1. Clear the area of bystanders especially small children.
2. Stop engine, set park brake, remove ignition key and wait for all moving parts to stop before dismounting.
3. Lift the guard and use a hammer and punch to remove the broken shear pin.
4. Install a replacement shear pin and tighten to the specified torque.
(Use 1/2"x 3" grade 2 hex bolt)



CAUTION

Guard is shown lifted for illustrative purposes only. Do not operate machine with guard lifted.

5. Be sure the plastic shield is adjusted to cover the yoke.
6. Close and secure guard.
7. Safety ring on front of gearbox input shaft should be in groove and inspected for wear. Replace if worn or disfigured.

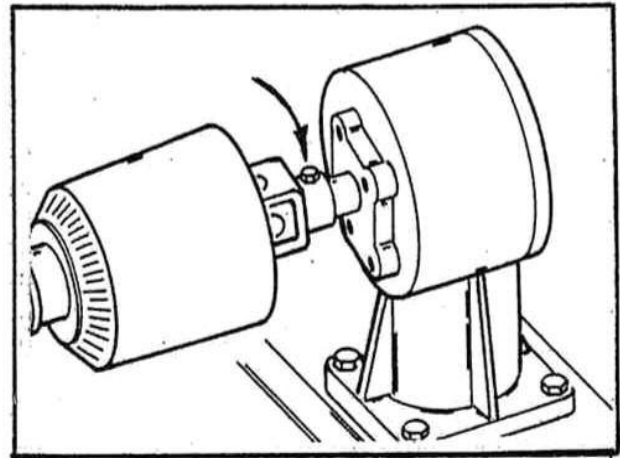

SHEAR PIN

Use only genuine Tebben replacement parts at all times. This shear bolt is designed to protect the machine from overloading.

IMPORTANT

(Use 1/2"x 3" grade 2 hex bolt)

BLADE REPLACEMENT

A blade may become bent, chipped or broken when using and have to be replaced.

When replacing a blade, follow this procedure:

1. Clear the area of bystanders, especially small children.
2. Raise the machine above the ground to provide access to the blades.
3. Stop engine, set park brake, remove ignition key and wait for all moving parts to stop before dismounting.
4. Support the machine with large blocks or safety stands.
5. Remove the nut through the access cover.
6. Push or tap the blade pin down.
7. Remove the old blade and replace with a new one.
8. Tap or drive the blade bolt back into position.
9. Tighten the mounting bolt to its specified torque.
10. The blades and stump jumper assembly are matched at the factory to minimize vibration. In most cases, both blades should be replaced if one requires changing to keep the assembly in balance. This is particularly true if the remaining blade is badly worn.
11. Repeat with other blade.
12. Swing the access cover back over the hole and tighten the nut.



WARNING

Do not operate the machine with the access cover open.

13. Remove the blocks or safety stands from under the frame.

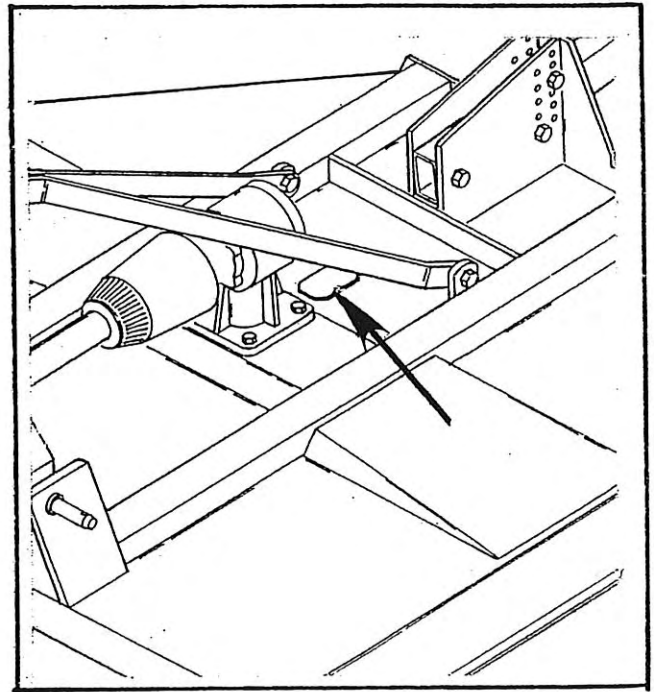

ACCESS COVER

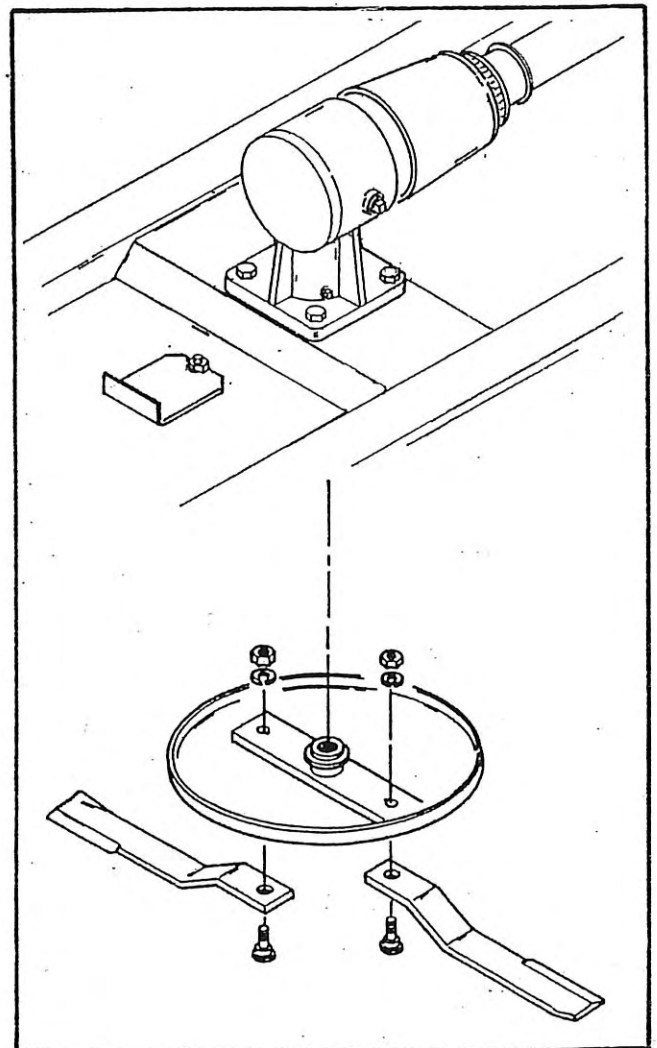

BLADE

DRIVELINE MAINTENANCE

The PTO driveline is designed to telescope to allow for dimensional changes as the machine goes through its operating range. A tubular guard encloses the driving components and is designed to turn relative to the driving components. The driveline should telescope easily and the guard turn freely on the shaft at all times. Annual disassembly, cleaning and lubrication is recommended to insure that all components function as intended. To maintain the driveline, follow this procedure:

1. Remove the driveline from the machine.
2. Pull driveline apart.
3. Use a screwdriver to pry the tabs out of the sleeves on each end. There are 2 tabs per guard.
4. Pull the shaft out of the plastic tubular guard.
5. Use a solvent to clean the male and female portions of the telescoping ends.
6. Apply a light coat of grease to each end.
7. Use a solvent to wash the grooves on each end where the tabs are located. Clean each tab also.
8. Apply a light coat of grease to each groove.
9. Insert the shaft into its respective guard and align the slots with the groove.
10. Insert the tabs through the slots and seat in the groove.
11. Check that each guard turns freely on the shaft.
12. Assemble the driveline.
13. Check that the driveline telescopes easily.
14. Replace any components that are damaged or worn.
15. Install the driveline on the machine.

GEARBOX MAINTENANCE

The heavy duty gearbox used on the Cutter will give many years of trouble-free service with minimal maintenance requirements. Maintain the gearbox by following this procedure:

1. Oil level:
 - a. Remove the level plug from the front of the gearbox.
 - b. The oil should just fill a few of the threads.
 - c. Add through the fill plug if required.

IMPORTANT

Check the oil level only when the unit is cold and the machine is on the level.

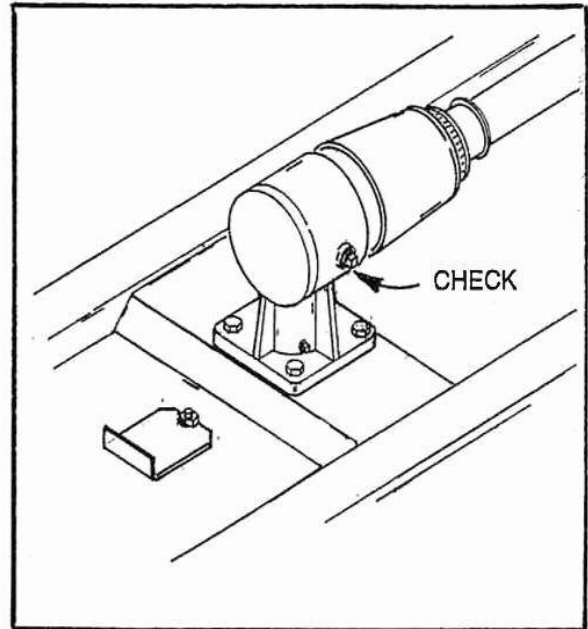

OPTIONAL SLIP CLUTCH MAINTENANCE

An optional slip clutch is available on the machine. Proper clutch operation requires that the friction plates be set at the required pressure and the material be clean. To ensure these requirements, follow this procedure:

1. Before first use or after a long storage, loosen set screw on pressure nut.
2. Back off pressure nut to free clutch plates.
3. Tighten pressure nut until the clutch plates are snug. Then tighten pressure nut another 1/4 turn.



WARNING

Machine is shown with guard lifted for illustrative purposes only. Do not operate machine with guard lifted.

4. Run the driveline at low idle to slip the clutch until it starts to smoke. This will remove the dirt, corrosion and surface gloss from the clutch plate faces.
5. Tighten the pressure nut another 1/2 turn to set the clutch plate pressure.
6. Tighten the set screw in the pressure nut to lock it in place.
7. Normally the clutch will slip at a 20% higher torque after the "run in" than before.
8. Check the temperature of the clutch after running for 20 minutes and every 8 hours after that. If the clutch is hot to the touch or smokes, reset the pressure nut or the clutch plates will burn up and fail. Tighten the pressure nut in 1/4 turn increments and try during operation. Readjust again as required.
9. The clutch should be set so it does not slip during normal operation. It should slip when the unit is overloaded from heavy cutting or when striking an obstruction. If it is set for too high a torque to slip, components will fail.

TROUBLE SHOOTING

The Tebben Rotary Cutter uses a pair of free-swinging blades on a rotor to cut grass and other types of weeds and brush. It is a simple and reliable system that requires minimal maintenance.

In the following section, we have listed many of the problems, causes, and solutions to the problems that you may encounter.

If you encounter a problem that is difficult to solve, even after having read through this trouble shooting guide, please call your local Tebben dealer or distributor. Before you call, please have this operator's manual from your machine and the model/serial number ready.

PROBLEM

CAUSE

SOLUTION

Blade pan and blades don't turn.

Broken shear pin.

Replace shear pin.

Poor cutting job.

Traveling too fast.

Slow down.

Blades dull.

Sharpen blades.

Grooves in grass.

Bent blade, straighten or replace blade.

Machine not level, level machine.

Scalping of grass.

Machine too low, raise machine.

Grass being left.

Traveling too fast, slow down.
Damaged blade, replace.

Gearbox seal leaking.

Oil overheating.
(Improper oil)

Improper oil should be replaced with specified oil (Section 5.1.1)

Worn seal.

Replace seal.

Improper installation of seal.

Replace seal.

Noisy gearbox.

Poor gear mesh.

Remove input shaft and gear, replace worn parts. Reassemble and use shims to give a gear backlash.

Clutch Slips.

Overloaded.
Clutch loose.
Clutch worn out.

Slow travel speed.
Tighten Springs on clutch plates.
Replace clutch components or assembly as required.

ASSEMBLY

The machine is shipped from the factory in a partially disassembled form that allows for easy and convenient shipping.

When preparing for the customer, follow this procedure:

1. Clear the area of bystanders.
2. Use 2 men to guide or direct and handle the heavy and bulky components.'
3. Use a crane, hoist or forklift of capacity and stability to handle the components.
4. Attach to the lifting device, remove tie-downs, lift from the truck and move to the assembly area. Drive slow and keep the machine close to the ground.
5. Remove the mounting frame, pins, gearbox guard and driveline from the frame and lay to the side.
6. Assemble the mounting frame to the front of the machine. Be sure the vertical frame is assembled so the mounting pin hole faces forward.
7. Install the 3 point hitch mounting pins.
8. Tighten the fasteners to their specified torque level.
9. Remove the top 2 cap screws from the input shaft cover.
10. Install the guard and tighten the cap screws to the specified torque (45 ft-lbs).
11. Lift the guard up to expose the input shaft.
12. If equipped with a shear bolt:
 - a. Remove shear pin bolt.
 - b. Clean the PTO driveline yoke and the input shaft.
- c. Remove the front shaft ring and slide the yoke over the shaft.
- d. Install the safety ring in the groove on the end of the input shaft.
- e. Install the shear pin through the input shaft and tighten.
- f. Flip the guard over the input shaft and clip in place.
- g. Check that all fasteners are tight.

13. If equipped with a slip clutch:

- a. Remove the nut on the end of the input shaft.
- b. Install the clutch on splined input shaft.
- c. Tighten nut on the input shaft to secure clutch.
- d. Assemble driveline to clutch. Tighten mounting bolt to their specified torque.
- e. Flip the guard over the input shaft and clip in place.
- f. Check that all fasteners are tight.



WARNING

Machine is shown with guard lifted for illustrative purposes only. Do not operate machine with guard lifted.

OPTIONAL EQUIPMENT

CHAIN GUARD DEFLECTORS

A Chain Guard deflector for the front and rear is available for the Rotary Cutter. Tebben recommends that the machine be equipped with these deflectors to minimize expelled debris.



SLIP CLUTCH

A Slip clutch on the gearbox input shaft is available from the factory. Specify the clutch in place of the shear pin when ordering from the factory.

STANDARD EQUIPMENT AND SPECIFICATIONS

	TC10-400	TC10-500	TC10-600
Cutting Width	48"	60"	72"
Transport Width	52"	64"	76"
Overall Length	80"	98"	108"
Cutting Height	3/4" Min	3/4" Min	3/4" Min
Hitch	Cat. I	Cat. I	Cat. I
Blade Carrier	Pan	Pan	Pan
Horsepower Required	15 Min.	20-40HP	20-40HP
Gearbox Rating: 540 RPM	30HP	40HP	40HP
Blade Tip Speed	12,000	14,000	14,000
Driveline	Cat. III	Cat. III	Cat. III
Deck Thickness	11 Ga.	11 Ga.	11 Ga.
Side Skirt	7 Ga.	7 Ga.	7 Ga.
Weight	430lbs	560lbs	605lbs
Front/Rear Chain Guards	Optional	Optional	Optional

BOLT TORQUE

CHECKING BOLT TORQUE

The tables shown below give correct torque values for various bolts and cap screws. Tighten all bolts to the torques specified in the chart unless otherwise noted. Check tightness of bolts periodically, using bolt torque chart as a guide. Make sure To replace worn out bolts and nuts with the same grade your machine came with.

ENGLISH TORQUE SPECIFICATIONS

Bolt Diameter	Bolt Torque		
	SAE 2	SAE 5	SAE 8
"A"	N.m (lb-ft)	N.m (lb-ft)	N.m (lb-ft)
1/4"	8 (6)	12 (9)	17 (12)
5/16"	13 (10)	25 (19)	36 (27)
3/8"	27 (20)	45 (33)	63 (45)
7/16"	41 (30)	72 (53)	100 (75)
1/2"	61 (45)	110 (80)	155 (115)
9/16"	95 (70)	155 (115)	220 (165)
5/8"	128 (98)	215 (160)	305 (220)
3/4"	225 (165)	390 (290)	540 (400)
7/8"	230 (170)	570 (420)	880 (650)
1"	345 (225)	850 (630)	1320 (970)

Torque figures indicated above are called for non-greased or non oiled threads and heads unless otherwise specified. Therefore, do not grease or oil bolts unless otherwise specified in this manual. When using locking elements, increase torque values by 5%.

Torque values for bolts are identified by their head markings.

IMPORTANT: Locking nuts on cylinders and pivoting components should only be tightened to the point where the bolt no longer turns. Over tightening of these nuts can result in damaged parts.

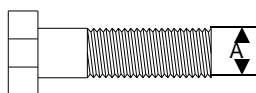
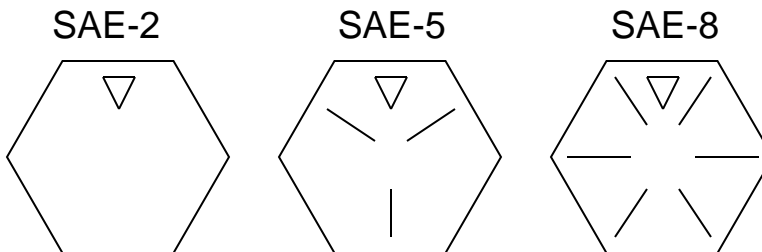

PARTS LIST

This manual contains a parts list for your machine. It is divided into major sections which correspond to the groups shown in the Table of Contents and accompanying illustration.

The first page of each major section lists the contents of that section, each of which consists of exploded views and related tabular listings.

WHEN ORDERING PARTS

Always give your dealer the Model and Serial Number of your machine to assist him in ordering and obtaining the correct parts. Use the exploded view and tabular listing of the area of interest to exactly identify the required part.

USING THE MANUAL

Parts data consists of exploded view illustrations and associated parts list tables which are read as follows:

ITEM

The item number is the identifier number from the illustration. For example, number 3 on an illustration points to a component which is item 3 on the accompanying table.

PART NUMBER

The part number is the number by which the component may be identified and ordered from TEBBEN ENTERPRISES and its network dealers.

DESCRIPTION

This column contains the name and description of the part.

ROTARY CUTTER (ROUND BACK)

MODEL TC10-400 4'

MODEL TC10-500 5'

MODEL TC10-600 6'

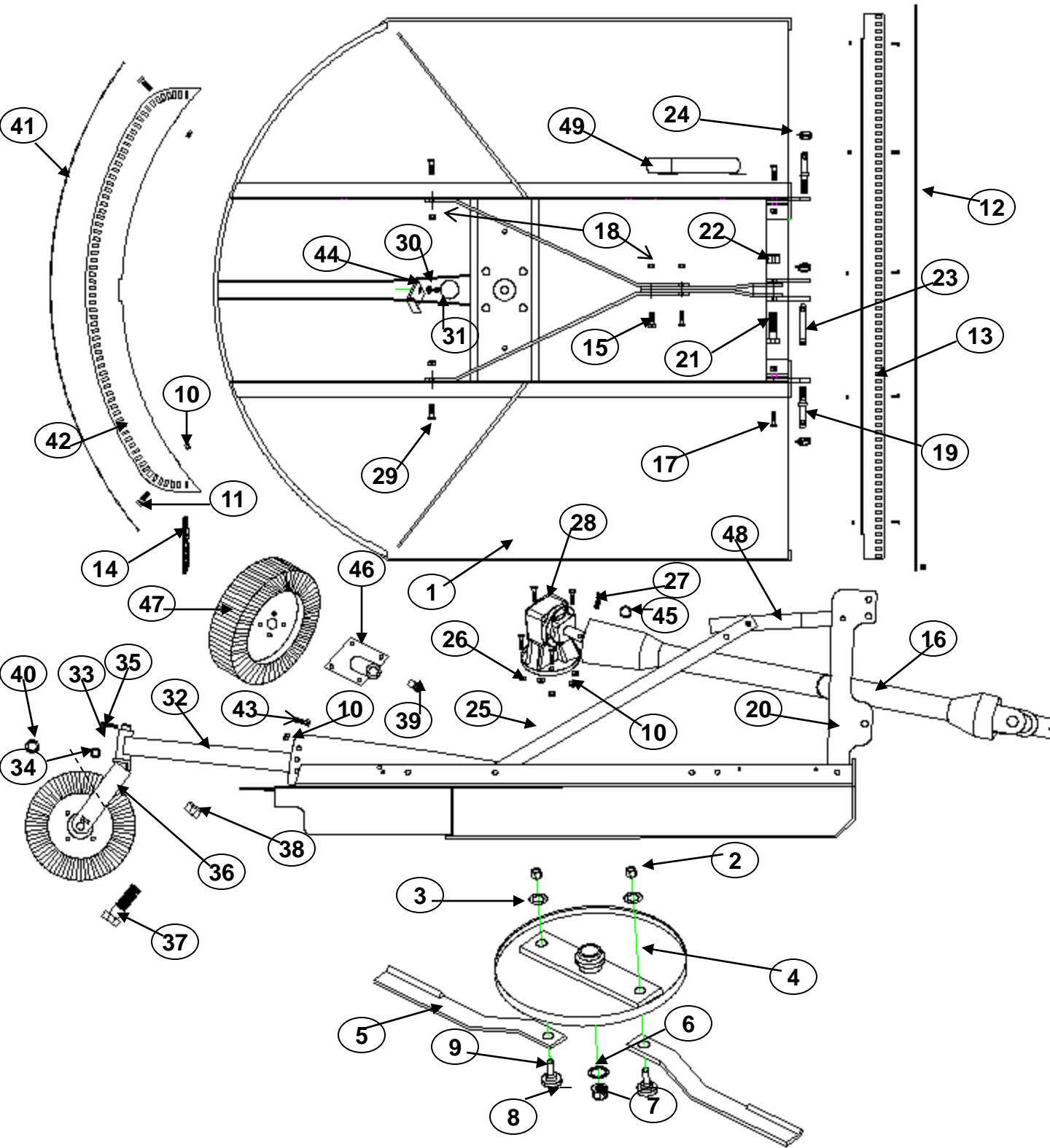

ROTARY CUTTER (ROUND BACK) PARTS LIST

MODEL TC10-400
MODEL TC10-500
MODEL TC10-600

REF.	PART NO.	DESCRIPTION	QTY.
1	64-40010	48" Deck	1
	64-50010	60" Deck	1
	64-60010	72" Deck	1
2	60-912	Blade Bolt Nut	2
3	60-913	Lock washer	2
4	60-750	Stump Jumper Pan	1
5	60-914	Blade, 48" Cut	2
	60-915	Blade, 60" Cut	2
	60-916	Blade, 72" Cut	2
6	64-660	Washer, Shim 1" ID 10 Ga.	1
7	64-661	Castle Nut	1
8	64-662	Cotter Pin	1
9	60-910	Blade Bolt	2
10	60-903	½-13 Center Lock Nut	8
11	60-909	½-13 x 1-1/4 Hex Bolt	7
12	60-4064	Chain Guard Front Cable, 48"	1
	60-5072	Chain Guard Front Cable, 60"	1
	60-6083	Chain Guard Front Cable, 72"	1
13	64-884	Front Chain Guard – 48"	1
13	60-865	Front Chain Guard – 60"	1
	60-989	Front Chain Guard – 72"	1
14	60-869	Chain – 3/16", 7 Links	1
15	60-908	5/8-11 x 2-1/2 Hex Bolt	2
16	60-9517	Driveline – 48" Deck, 40 H.P.	1
	60-9618	Driveline – 60" Deck, 40 H.P.	1
	60-9728	Driveline – 72" Deck, 40 H.P.	1
17	60-837	5/8-11 x 2 Hex Bolt	7
18	60-838	5/8-11 Center Lock Nut	6
19	60-925	Lower 3-Pt Pin w/ Nut & Lock washer	2
20	64-80010L	Upper 3-Pt Arm LH	1
	64-80010R	Upper 3-Pt Arm RH	1
21	60-924	¾-10 x 4 Hex Bolt	1
22	60-925	¾-10 Center Lock Nut	1
23	60-870	Upper 3-Pt Pin	1
24	60-871	Lynch Pin	3
25	64-80013	Brace Arm	2
26	60-901	5/8-11 Nylon Lock Nut	4
27	60-930	½-13 x 3 Hex Bolt Gr. 2 (Shear Bolt)	1
28	60-950	Gearbox, 48" Deck – 40 H.P.	1
	60-960	Gearbox, 60" & 72" Deck - 40 H.P.	1
29	60-898	5/8-11 x 1-1/2 Hex Bolt	2
30	60-905	5/16 Flat Washer	1
31	60-904	5/16-18 Center Lock Nut	1
32	60-725	Rear Arm Weldment	1
33	60-741	Grease Fitting, Drive in	1
34	60-740	Bushing Washer, 1-1/4 ID	1
35	60-742	3/8 x 2-1/4 Expand Pin	1
36	60-700	Wheel Fork	1
37	60-748	1-8 x 8-1/2 Hex Bolt	1
38	60-749	1-8 Hex Nut, Nylon Lock	1
39	60-743S	Steel Bushing	2
40	60-747	Spacer	2

**ROTARY CUTTER (ROUND BACK)
PARTS LIST**

**MODEL TC10-400
MODEL TC10-500
MODEL TC10-600**

REF.	PART NO.	DESCRIPTION	QTY.
41	60-4066	Chain Guard Rear Cable – 48”	1
	60-5068	Chain Guard Rear Cable – 60”	1
	60-6074	Chain Guard Rear Cable – 72”	1
42	64-80048	Rear Chain Guard – 48”	1
	64-80060	Rear Chain Guard – 60”	1
	64-80072	Rear Chain Guard – 72”	1
43	60-902	½-13 x 3 Hx Blt 5NC	1
44	60-875	Access Cover	1
45	60-9001	External Snap Ring	1
46	60-746H	Hub Only W/ Steel Bushings	1
47	60-746L	Laminated Wheel Only	1
48	64-80012	Linkage Arm	1
49	01-473	Operators Manual Container	1

ROTARY CUTTER (ECONOMY)

MODEL TC07-40	40"
MODEL TC07-400	4"
MODEL TC07-500	5"
MODEL TC07-600	6"

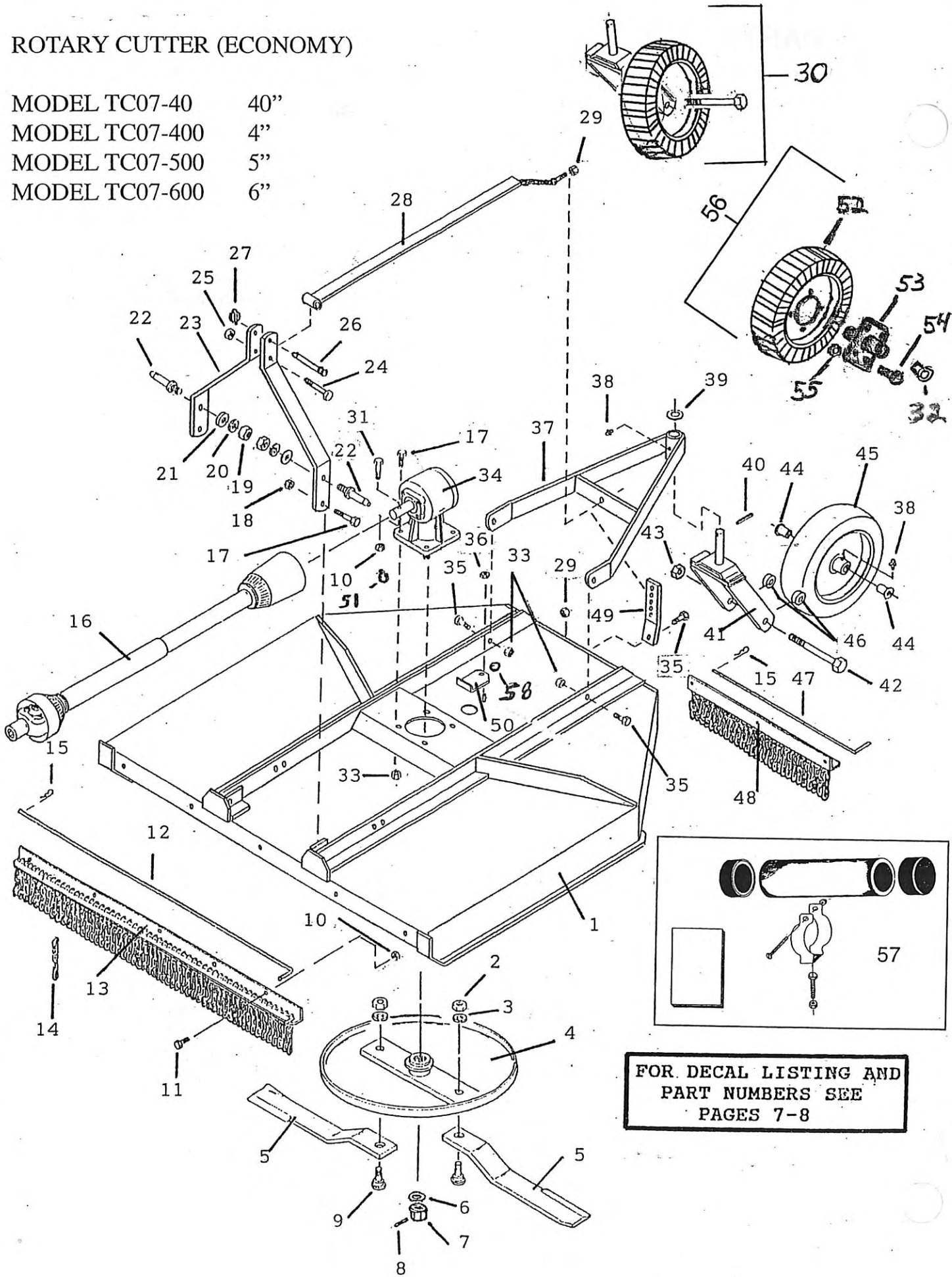

FOR DECAL LISTING AND
PART NUMBERS SEE
PAGES 7-8

ROTARY CUTTER (ECONOMY)

PARTS LIST

MODEL TC07-40
MODEL TC07-400
MODEL TC07-500
MODEL TC07-600

REF	PART NO.	DESCRIPTION	QTY
1	64-407	Deck, 40" (2007 & Newer)	1
	64-4007	Deck, 48" (2007 & Newer)	1
	64-5007	Deck, 60" (2007 & Newer)	1
	64-6007	Deck, 72" (2007 & Newer)	1
2	60-912	Blade Bolt Jam Nut, 1-1/8"	2
3	60-913	Lock Washer, 1-1/8"	2
4	60-750	Stump Jumper Pan	1
5	64-820	Blade, 40" Cut	2
	60-914	Blade, 48" Cut	2
	60-915	Blade, 60" Cut	2
	60-916	Blade, 72" Cut	2
6	64-660	Washer, Shim 1" ID x 10GA	1
7	64-661	Castle Nut, 1" NF	1
8	64-662	Cotter Pin, 3/16 x 2-1/4	1
9	60-910	Blade Mtg Bolt	2
10	60-903	1/2" Hx Nut, Centerlock	1
11	60-909	1/2-13 x 1-1/4 Hx Bolt	Var.
12	60-863	Front Chain Guard Cable - 40"	1
	60-864	Front Chain Guard Cable - 48"	1
	60-865	Front Chain Guard Cable - 60"	1
	60-866	Front Chain Guard Cable - 72"	1
13	64-874	Front Chain Guard - 40"	1
	64-884	Front Chain Guard - 48"	1
	64-885	Front Chain Guard - 60"	1
	64-886	Front Chain Guard - 72"	1
14	60-869	Chain, 7 Links	Var.
15	709	Hairpin	2
16	64-9517	Driveline - 40" & 48" Deck (2007 & Newer)	1
	60-9567	Driveline - 60" Deck (2007 & Newer)	1
	60-9617	Driveline - 72" Deck (2007 & Newer)	1
17	60-837	5/8-11 x 2 Hx Bolt	6
18	60-838	5/8-11 Hx Nut, Centerlock	5
19	60-923	7/8-14 Hx Nut	2
20	60-922	7/8 Lock Washer	2
21	60-921	7/8 Flat Washer	2
22	60-920	Lower 3PT Hitch Pin	2
23	64-800	Upper 3PT Arm	2
24	60-924	3/4-10 x 4 Hex Bolt	1
25	60-925	3/4-10 Hx Nut, Centerlock	1
26	60-870	Upper 3PT Pin	1
27	60-871	Lynch Pin	3
28	64-7407	Lift Strap - 40" Deck (2007 & Newer)	1
	64-7487	Lift Strap - 48" Deck (2007 & Newer)	1
	64-7607	Lift Strap - 60" Deck (2007 & Newer)	1
	64-7727	Lift Strap - 72" Deck (2007 & Newer)	1
29	60-838	5/8-11 Hx Nut, Centerlock	1
30	61-700A	Wheel Assy Complete	1
31	60-930	Shear Bolt - 1/2-13 x 3 Hx Bolt Gr.2	1
32	60-743S	Steel Bushing	2
33	60-901	5/8-11 Hx Nut, Nylock	4
34	60-950	Gearbox, 40" & 48" Deck	1
	60-960	Gearbox, 60" & 72" Deck	1
35	60-898	5/8-11 x 1-1/2 Hx Bolt	3
36	60-904	5/16-18 Hx Nut, Centerlock	1
37	64-7207	Wheel Mount (2007 & Newer)	1
38	60-741	Grease Fitting	1
39	60-740	Bushing Washer, 1-1/4 ID	1
40	60-742	Expand Pin, 3/8 x 2-1/4	1

ROTARY CUTTER (ECONOMY)
PARTS LIST

MODEL TC07-40
MODEL TC07-400
MODEL TC07-500
MODEL TC07-600

REF	PART NO.	DESCRIPTION	QTY
41	60-700	Wheel Fork	1
42	60-748	1-8 x 8-1/2 Hx Bolt	1
43	60-749	1-8 Hx Nut, Nylock	1
44	60-743	Nylon Bushing	2
45	60-745	Rim & Tire (Hard Rubber) OBSOLETE	1
46	60-747	Wheel Spacer	2
47	64-867	Rear Chain Guard Cable - 40" & 60" Deck	1
	64-862	Rear Chain Guard Cable - 48" Deck	1
	64-868	Rear Chain Guard Cable - 72" Deck	1
48	64-894	Rear Chain Guard - 40" & 60" Deck	1
	64-893	Rear Chain Guard - 48" Deck	1
	64-896	Rear Chain Guard - 72" Deck	1
49	64-805	Wheel Height Adjustment Plate	1
50	60-875	Access Cover	1
51	60-9001	External Snap Ring	1
52	60-746L	Laminated Wheel Only	1
53	60-746HN	Hub Only, Cast	1
54	60-746H	Hub Only W/ Steel Bushings	1
55	2109-803	1/2 Hx Nut, NF	4
56	60-746LHNA	Wheel Assy Complete	1
57	64-1010	Manual Container	1
58	60-905	5/16 Flat Washer	1

ROTARY CUTTER (MEDIUM DUTY)

MODEL TC94-400 4'
 MODEL TC94-500 5'
 MODEL TC94-600 6'

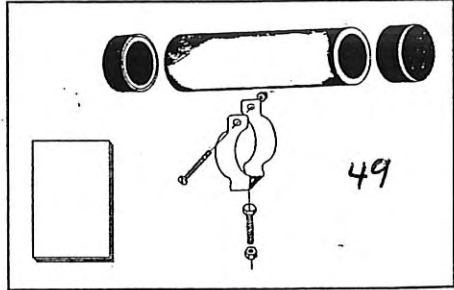
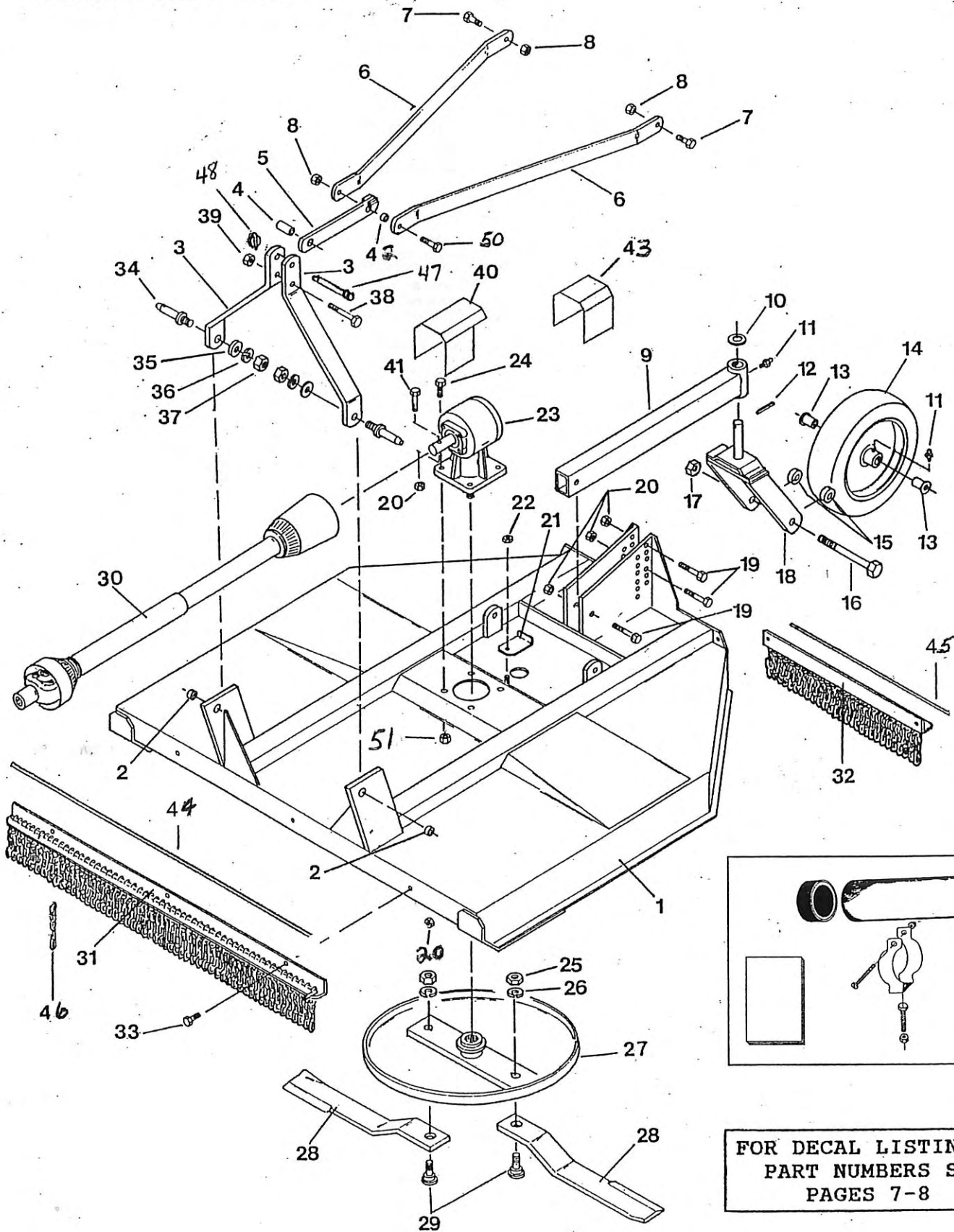

FOR DECAL LISTING AND
 PART NUMBERS SEE
 PAGES 7-8

ROTARY CUTTER (Medium Duty)

PARTS LIST

MODEL TC94-400

MODEL TC94-500

MODEL TC94-600

REF	PART NO.	DESCRIPTION	QTY
1	60-400	Deck, 48"	1
	60-500	Deck, 60"	1
	60-600	Deck, 72"	1
2	60-852	Bushing, 3PT Arm	2
3	60-820	Upright	2
4	60-851	Bushing, Linkage	1
5	60-810	Linkage Arm	1
6	60-805	Attaching Brace - 48"	2
	60-800	Attaching Brace - 60" & 72"	2
7	60-898	5/8-11 x 1-1/2 Hx Bolt	2
8	60-838	5/8-11 Hx Nut, Centerlock	3
9	60-725	Rear Arm Weldment	1
10	60-740	Bushing Washer, 1-1/4 ID	1
11	60-741	Grease Fitting	1
12	60-742	Expand Pin, 3/8 x 2-1/4	1
13	60-743	Nylon Bushing	2
14	60-745	Rim & Tire (Hard Rubber) OBSOLETE	1
15	60-747	Spacer	2
16	60-748	1-8 x 8-1/2 Hx Bolt	1
17	60-749	1-8 Hx Nut, Nylock	1
18	60-700	Wheel Fork	1
19	60-902	1/2-13 x 3 Hx Bolt, Gr. 5	3
20	60-903	1/2-13 Hx Nut, Centerlock	4
21	60-875	Access Cover	1
22	60-904	5/16-18 Hx Nut, Centerlock	1
23	60-950	Gearbox, 48" Deck	1
	60-960	Gearbox, 60" & 72" Deck	1
24	60-837	5/8-11 x 2 Hx Bolt	4
25	60-912	Blade Bolt Jam Nut, 1-1/8	2
26	60-913	Lock Washer, 1-1/8	2
27	60-750	Stump Jumper Pan	1
28	60-914	Blade, 48" Deck	2
	60-915	Blade, 60" Deck	2
	60-916	Blade, 72" Deck	2
29	60-910	Blade Mtg Bolt	2
30	60-951	Driveline - 48" Deck	1
	60-956	Driveline - 60" Deck	1
	60-961	Driveline - 72" Deck	1
31	60-884	Front Guard Deflector - 48" Deck	1
	60-885	Front Guard Deflector - 60" Deck	1
	60-886	Front Guard Deflector - 72" Deck	1
32	60-894	Rear Guard Deflector - 48" Deck	1
	60-895	Rear Guard Deflector - 60" Deck	1
	60-896	Rear Guard Deflector - 72" Deck	1
33	60-909	1/2-13 x 1-1/4 Hx Bolt	Var.
34	60-920	Lower 3PT Hitch Pin	2
35	60-921	7/8 Flat Washer	2
36	60-922	7/8 Lock Washer	2
37	60-923	7/8-14 Hx Nut	2
38	60-924	3/4-10 x 4 Hx Bolt	1
39	60-925	3/4-10 Hx Nut, Centerlock	1
40	60-840	PTO Guard (Bondioli)	1
41	60-930	1/2-13 x 3 Hx Bolt Gr. 2	1
42	60-853	Bushing	1
43	60-843	PTO Guard (ITG. or Omni)	1

ROTARY CUTTER (Medium Duty)

PARTS LIST

MODEL TC94-400

MODEL TC94-500

MODEL TC94-600

<u>REF</u>	<u>PART NO.</u>	<u>DESCRIPTION</u>	<u>QTY</u>
44	60-864	Front Chain Guard Cable - 48"	1
	60-865	Front Chain Guard Cable - 60"	1
	60-866	Front Chain Guard Cable - 72"	1
45	60-862	Rear Chain Guard Cable - 48"	1
	60-867	Rear Chain Guard Cable - 60"	1
	60-868	Rear Chain Guard Cable - 72"	1
46	60-869	Chain, 7 Links	Var.
47	60-870	Upper 3PT Pin	1
48	60-871	Lynch Pin	3
49	64-1010	Manual Container	1
50	60-908	5/8-11 x 2-1/2 Hx Bolt	1
51	60-901	5/8-11 Hx Nut, Nylock	4

ROTARY CUTTER (HEAVY DUTY)

MODEL TC94-500-MC 5'
 MODEL TC94-600-MC 6'
 MODEL TC94-700-MC 7'

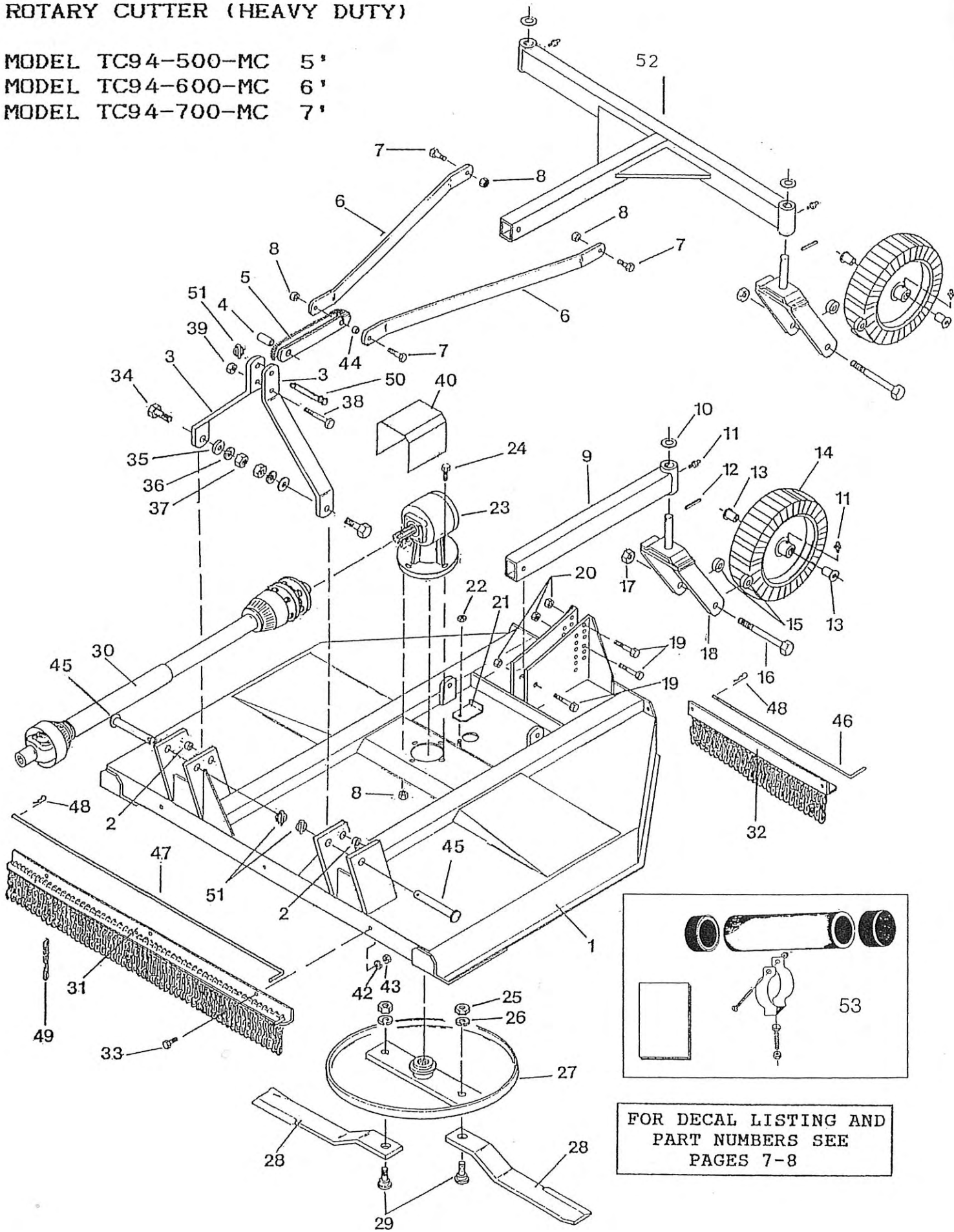

FOR DECAL LISTING AND
 PART NUMBERS SEE
 PAGES 7-8

**ROTARY CUTTER (HEAVY DUTY)
PARTS LIST**

MODEL TC94-500MC
MODEL TC94-600MC
MODEL TC94-700MC

REF	PART NO.	DESCRIPTION	QTY
1	60-500MC	Deck - 60"	1
	60-600MC	Deck - 72"	1
	60-700MC	Deck - 84"	1
2	60-852	Bushing, Upright	2
3	60-820	Upright	2
4	60-851	Bushing, Large	1
5	60-813	Linkage Arm	1
6	60-800	Attaching Brace	2
7	60-908	5/8-11 x 2-1/2 Hx Bolt	1
8	61-625	3/4-10 Hx Nut, Nylock	4
9	60-725	Rear Arm Weldment	1
10	60-740	Bushing Washer, 1-1/4	1
11	60-741	Grease Fitting, Drive In	1
12	60-742	Expand Pin, 3/8 x 2-1/4	1
13	60-743S	Steel Bushing	2
14	60-746	Rim & Tire (Laminated)	1
15	60-747	Spacer	2
16	60-748	1-8 x 8-1/2 Hx Bolt	1
17	60-749	1-8 Hx Nut, Nylock	1
18	60-700	Wheel Fork	1
19	60-902	1/2-13 x 3 Hx Bolt	3
20	60-903	1/2-13 Hx Nut, Centerlock	3
21	60-875	Access Cover	1
22	60-904	5/16-18 Hx Nut, Centerlock	1
23	60-975	Gearbox - 60" & 72" Deck	1
	60-985	Gearbox - 84" Deck	1
24	60-934	3/4-10 x 2-1/2 Hx Bolt	4
25	60-912	Blade Bolt Jam Nut, 1-1/8	2
26	60-913	Lock Washer, 1-1/8	2
27	60-755	Stump Jumper Pan	1
28	60-915	Blade - 60" Deck	2
	60-916	Blade - 72" Deck	2
	60-987	Blade - 84" Deck	2
29	60-910	Blade Mtg Bolt	2
30	60-976	Driveline - 60" Cutter	1
	60-981	Driveline - 72" Cutter	1
	60-986	Driveline - 84" Cutter	1
31	60-855	Front Guard Deflector - 60" Deck	1
	60-886	Front Guard Deflector - 72" Deck	1
	60-887	Front Guard Deflector - 84" Deck	1
32	60-894	Rear Guard Deflector - 60" Deck	1
	60-895	Rear Guard Deflector - 72" Deck	1
	60-988	Rear Guard Deflector - 84" Deck	1
33	60-909	1/2-13 x 1-1/4 Hx Bolt	Var.
34	60-907	7/8-9 x 2-1/2 Hx Bolt	2
35	60-921	7/8 Flat Washer	2
36	60-922	7/8 Lock Washer	2
37	60-923	7/8-9 Hx Nut	2
38	60-924	3/4-10 x 4 Hx Bolt	1
39	60-925	3/4-10 Hx Nut, Centerlock	1
40	60-845	PTO Guard	1
43	60-903	1/2-13 Hx Nut, Centerlock	Var.
44	60-853	Bushing	1
45	60-991	Lower 3PT Pin	2

**ROTARY CUTTER (HEAVY DUTY)
PARTS LIST**

MODEL TC94-500MC
MODEL TC94-600MC
MODEL TC94-700MC

<u>REF</u>	<u>PART NO.</u>	<u>DESCRIPTION</u>	<u>QTY</u>
46	60-865	Front Chain Guard Cable - 60" Deck	1
	60-866	Front Chain Guard Cable - 72" Deck	1
	60-989	Front Chain Guard Cable - 84" Deck	1
47	60-867	Rear Chain Guard Cable - 60" Deck	1
	60-868	Rear Chain Guard Cable - 72" Deck	1
	60-990	Rear Chain Guard Cable - 84" Deck	1
48	709	Hair Pin, 711 (OBSOLETE)	N/A
49	60-869	Chain, 7 Links	Var.
50	60-870	Upper 3PT Pin	1
51	60-871	Lynch Pin	3
52	60-965	Tail Wheel Frame	1
53	64-1010	Manual Container	1

OPTIONAL PULL TYPE HITCH ASSEMBLY
TC94-500-MC, TC94-600-MC, TC94-700-MC

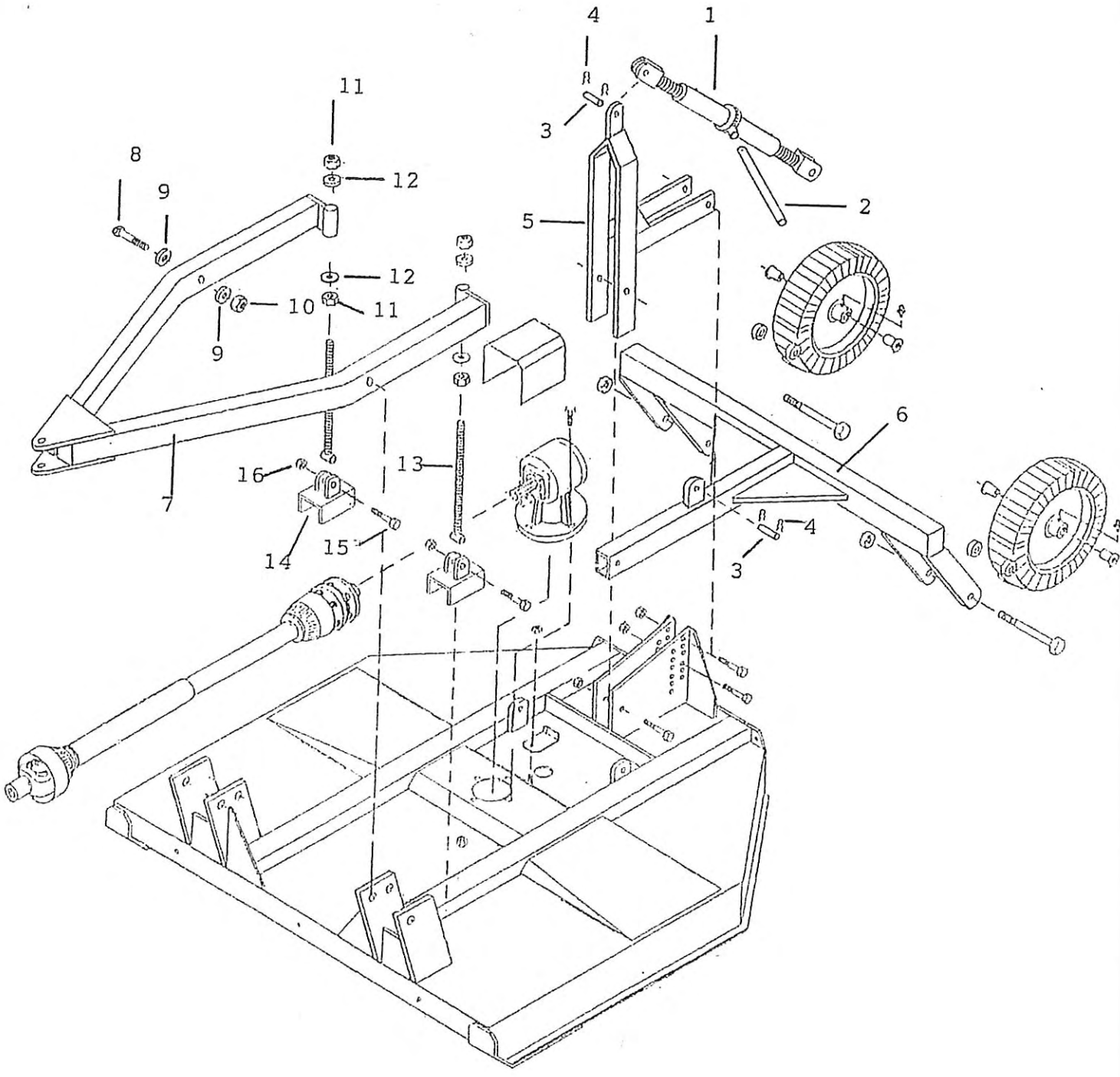

**OPTIONAL PULL TYPE HITCH ASSEMBLY
TC94-500MC, TC94-600MC, TC94-700MC**

REF	PART NO.	DESCRIPTION	QTY
1	61-665	Screw Jack (Complete)	1
2	61-663	Screw Jack Handle	1
3	61-667	Hitch Pin	2
4	61-66	Keeper	4
5	60-948	Height Adjustment Bracket	1
6	60-955	Trail Wheel Frame (Non Swivel)	1
7	60-993	Hitch	1
8	60-1000	7/8"-9 x 4" Hx Bolt	2
9	60-921	7/8" Flat Washer	4
10	60-1001	7/8"-9 Hx Nut, Centerlock	2
11	CT84-67	1"-8 Hx Nut	4
12	CT84-68	1" Flat Washer	4
13	60-940	Threaded Rod NC.	2
14	60-943	Channel Shoe	2
15	TM76-00-44	5/8"-11 x 3" Hx Bolt	2
16	TM76-00-43	5/8"-11 Hx Nut, Centerlock	2

**GEAR BOX (40 HP.)
ECONOMY & MEDIUM DUTY CUTTERS**

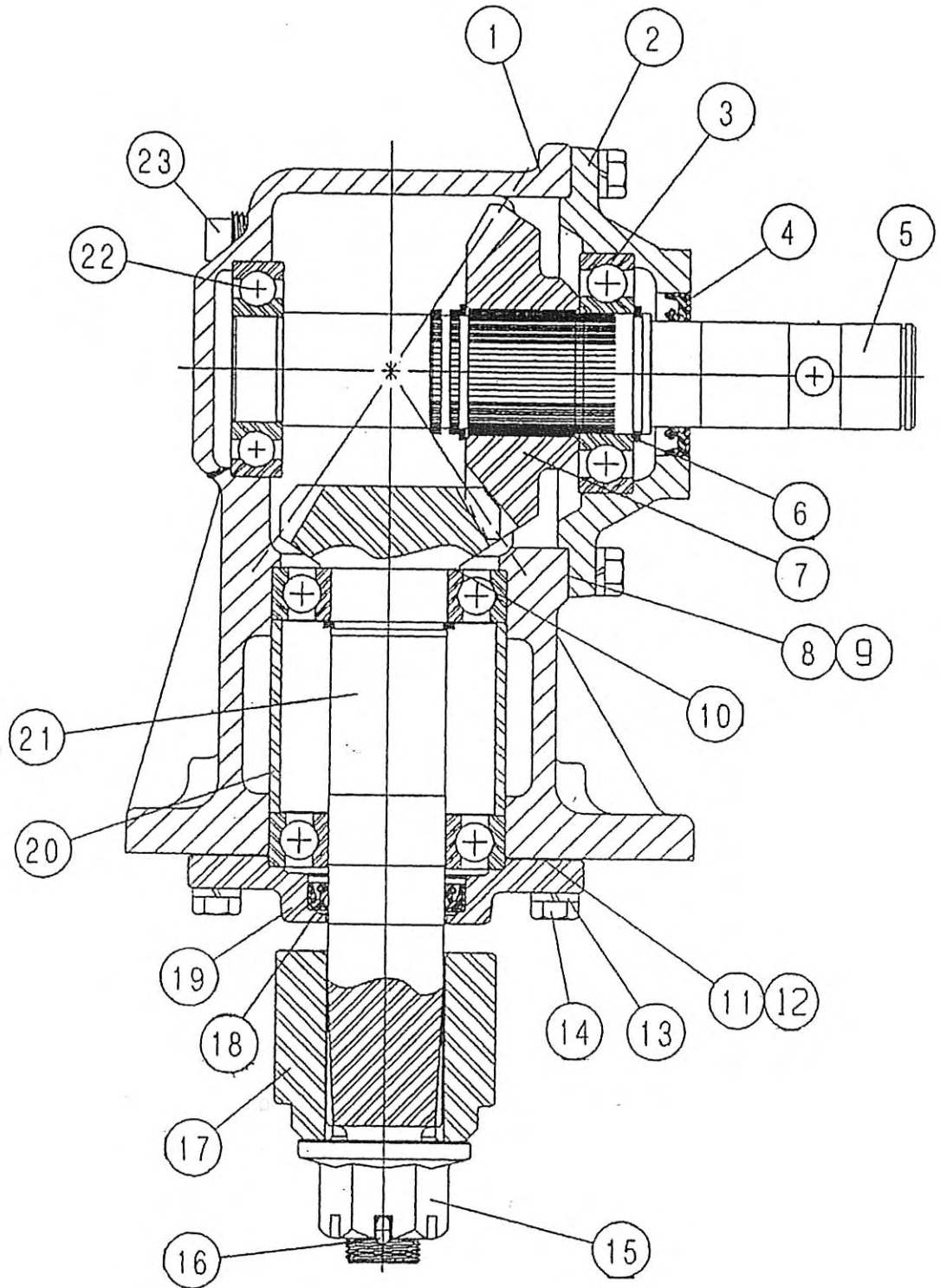

MODELS

ECONOMY

MEDIUM

TC96-40	3.5'
TC96-400	4'
TC96-500	5'
TC96-600	6'

TC94-400	4'
TC94-500	5'
TC94-600	6'

**GEAR BOX (40 HP.)
ECONOMY & MEDIUM DUTY CUTTERS**

REF.	PART NO.	QTY.	DESCRIPTION
1	18-010	1	HOUSING
2	20-007	1	INPUT CAP
3	04-003	3	BALL BEARING 208K
4	05-002	1	INPUT SHAFT SEAL
5	02-010	1	INPUT SHAFT
6	21-012	3	RETAINING RING
7	03-001	1	22 TOOTH INPUT GEAR, TC96-500, TC96-600, TC94-500, TC94-600
	03-003	1	29 TOOTH INPUT GEAR, TC96-40, TC96-400, TC94-400
8	08-004A	VAR.	INPUT GASKET (0.30)
9	08-004B	VAR.	INPUT GASKET (0.13)
10	17-004	1	STEEL SHIM (0.20)
11	08-005A	VAR.	OUTPUT CAP GASKET (0.30)
12	08-005B	VAR.	OUTPUT CAP GASKET (0.13)
13	07-001	10	LOCKASHER, 3/8"
14	06-008	10	CAP SCREW, 3/8"-16X1"
15	11-008	1	SLOTTED FLANGE, HEXNUT, 1" - 14
	11-007	1	SLOTTED HEXNUT
	07-005	1	BLADE HUB WASHER
16	12-003	1	COTTER PIN
17	15-001	1	BLADE HUB
18	05-005	1	OUTPUT SHAFT SEAL
19	20-003	1	OUTPUT CAP
20	10-002	1	OUTPUT BEARING SPACER
21	03-002	1	15 TOOTH OUTPUT SFT & PINION, TC96-500, TC96-600, TC94-500 TC94-600
	03-004	1	15 TOOTH OUTPUT SFT & PINION, TC96-40, TC96-400, TC94-400
22	04-004	1	BALL BEARING 207K
23	09-002	1	OIL FILL PLUG, 1/2"
24	09-005	1	OIL LEVEL PLUG, 1/8"

**GEARBOX (75 HP.)
HEAVY DUTY CUTTERS**

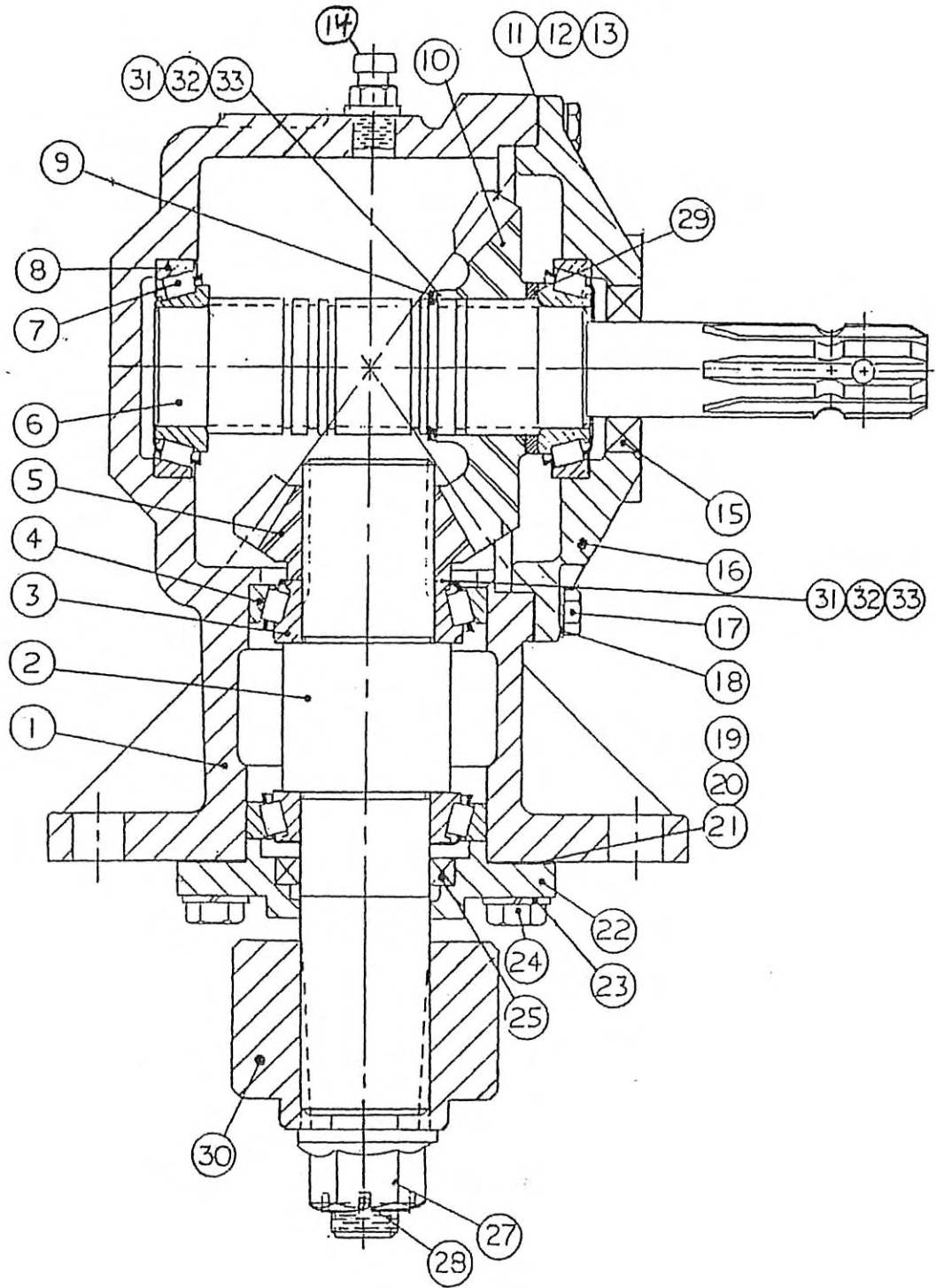

MODELS

TC94-500-MC	5'
TC94-600-MC	6'
TC94-700-MC	7'

HEAVY DUTY CUTTERS

01-114 5', 6' HD CUTTER & 7', 8', & 10' DBL CUTTERS

01-115 7' HD CUTTER

REF.	PART NO.	QTY.	DESCRIPTION
1	18-027	1	HOUSING
2	02-053	1	OUTPUT SHAFT
3	04-010	2	#368 BEARING CONE
4	04-009	2	#362 BEARING CUP
5	03-061	1	OUTPUT PINION 13 TOOTH, TC94-500MC, TC94-600MC
	03-062	1	OUTPUT PINION 14 TOOTH, TC94-700MC
6	02-054	1	INPUT SHAFT
7	04-007	2	#LM603049 BEARING CONE
8	04-008	2	#LM603014 BEARING CUP
9	21.001	1	RETAINING RING
10	03-060	1	INPUT GEAR 19 TOOTH, TC94-500MC, TC94-600MC
	03-063	1	INPUT GEAR 17 TOOTH, TC94-700MC
11	08-006	VAR.	INPUT CAP GASKET 0.30
12	08-007	VAR.	INPUT CAP GASKET 0.25
13	08-008	VAR.	INPUT CAP GASKET 0.40
14	09-011	1	S PSI-M18 X 1.5 BREATHER
15	05-014	1	INPUT SHAFT OIL SEAL
16	20-026	1	INPUT CAP
17	06-017	8	3/8"-16 UNC. 1-1/4 CAP SCREW
18	07-001	8	LOCKWASHER, 3/8"
19	08-001	VAR.	OUTPUT CAP GASKET 0.30
20	08-002	VAR.	OUTPUT CAP GASKET 0.25
21	08-003	VAR.	OUTPUT CAP GASKET 0.40
22	20-025	1	OUTPUT CAP
23	07-010	4	LOCKWASHER, 1/2"
24	06-018	4	1/2" -13UNCX 1-1/2 CAP SCREW
25	05-003	1	OUTPUT SHAFT OIL SEAL
26	09-012	1	M18X1.5 OIL LEVEL PLUG
27	11-008	1	1" - 14 FLANGED NUT
28	12-003	1	COTTER PIN
29	10-027	1	GEAR SPACER, TC94-500MC, TC94-600MC
	10-028	1	GEAR SPACER, TC94-700MC
30	15-006	1	2-1/2" BLADE HUB
31	17-001	1	SHIM .040
32	17-002	1	SHIM .030
33	17-003	1	SHIM .050

2007 & Newer Driveshaft
Economy & Medium Duty Cutters

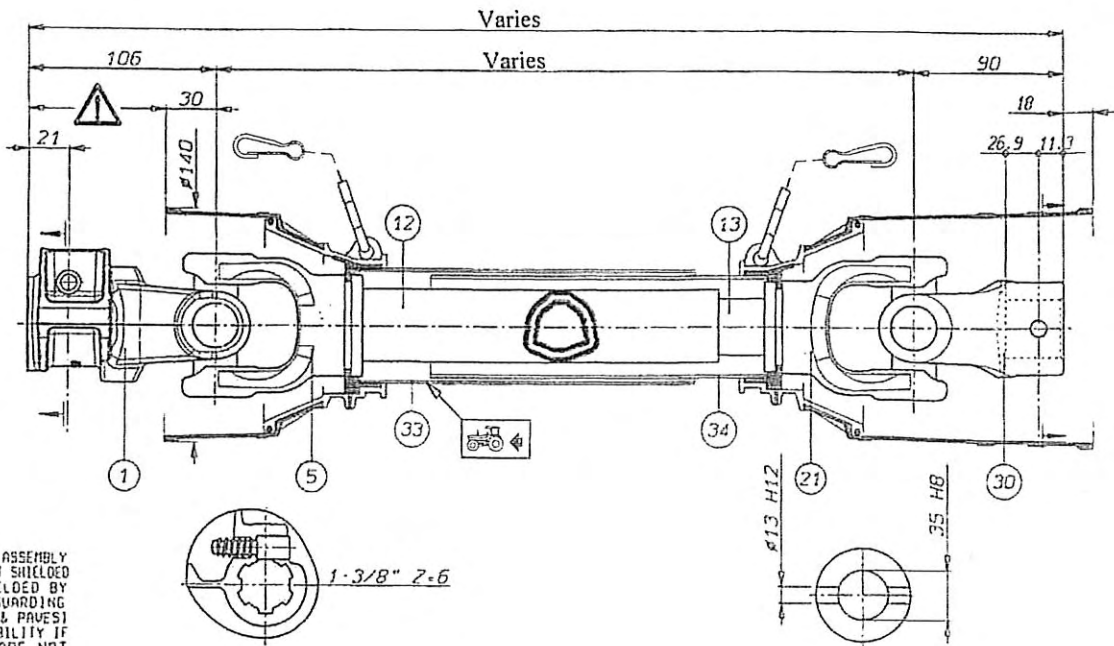

WARNING!
SECTIONS OF THE ASSEMBLY MARKED  ARE NOT SHIELDED AND MUST BE SHIELDED BY AN INTERACTIVE GUARDING SYSTEM. BOHDI (L) & PAVESI DECLINES RESPONSIBILITY IF PROPER GUARDS ARE NOT PROVIDED OR MAINTAINED.

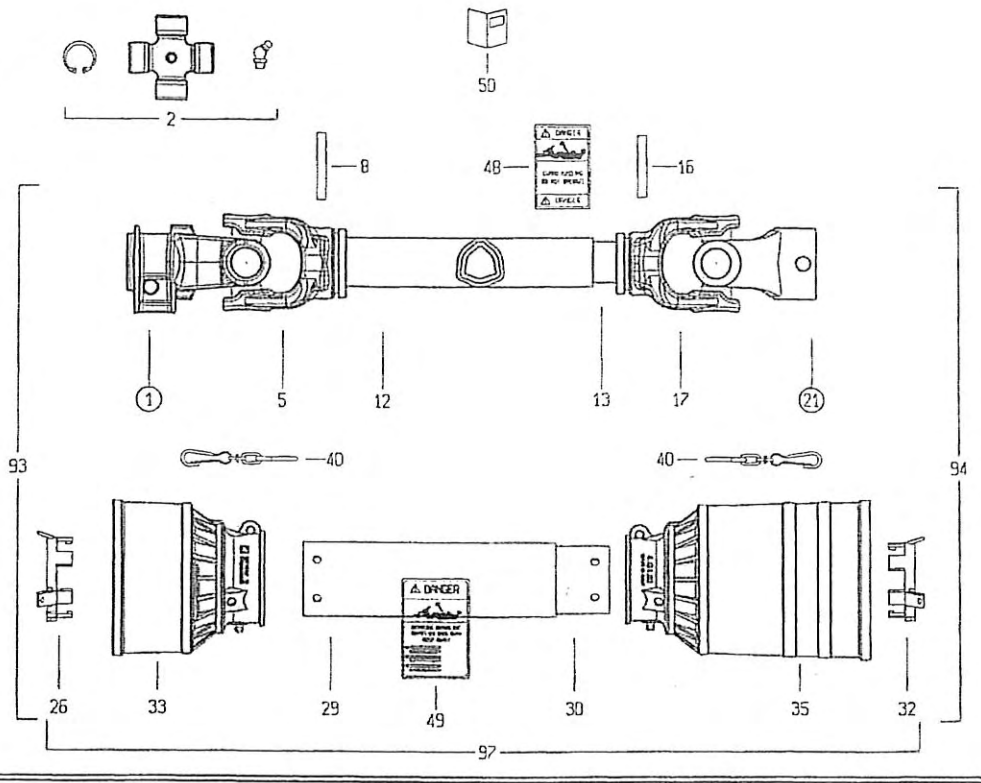

①

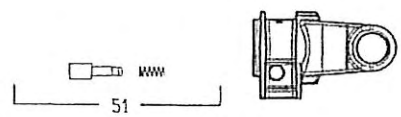

**2007 & Newer Driveshaft
Economy & Medium Duty Cutters**

	60-9517	60-9567	60-9617	TEBBEN DRIVESHAFT ASSEMBLY PART#	
	40" & 48"	60"	72"		
Ref.	Part#	Part#	Part#	Qty Req'd	Description
1	5070E0355	5070E355	5070E355	1	YOKE #4/S4 1-3/8" z6 SHROUDED PIN (007)
2	4120E0011R25	4120E0011R25	4120E0011R25	2	CROSS KIT #4 27x74.6 ZERK IN BODY
5	204046851	204046851	204046851	1	YOKE #4 OUTER TUBE
8	341038000R10	341038000R10	341038000R10	1	FLEXIBLE ROLL PIN #3/4 OUTER 8x60MM
12	225120470	225120600	225120750	1	CARDAN DRIVE TUBE OUTER
13	225100470	225100600	225100750	1	CARDAN DRIVE TUBE INNER
16	341048000R10	341048000R10	341048000R10	1	FLEXIBLE ROLL PIN #3/4 1.-2. 0 8x55MM
17	204046852	204046852	204046852	1	YOKE #4 INNER TUBE
21	211044955	211044955	211044955	1	YOKE #4 RB CUTTER 1/2" PH 63481
26	255040005R02	255040005R02	255040005R02	1	SHEILD SUPPORT #3-4 OUTER 4G502
29	236680417	236680547	236680697	1	SAFETY TUBE
30	236670417	236670547	236670697	1	SAFETY TUBE
32	255040006R02	255040006R02	255040006R02	1	SHEILD SUPPORT #3-4 INNER 4G602
33	517040030	517040030	517040030	1	O. CONE SHEILD CONE #3-4 OUTER STD (F1)
35	517040024	517040024	517040024	1	I. CONE SHEILD CONE #3-4 INNER (F4)
40	252000050R02	252000050R02	252000050R02	2	SHEILD CHAIN S-HOOK + 60 MM CLIP
48	399143000	399143000	399143000	1	DANGER LABEL - OUTER DRIVE TUBE
49	399141000	399141000	399141000	1	DANGER/SHEILD LABEL - OUTER PLASTIC TUBE
50	399A10000	399A10000	399A10000	1	INSTRUCTION BOOKLET USA
51	40300000R10	40300000R10	40300000R10	1	COMPLETE PUSH PIN 1-3/8" Z6/Z21
93	7E14061UC007	7E14074UC007	7E14089UC007	1	
94	8I14061UC002	8I14074UC001	8I14089UC001	1	
97	4F0406111UC	4F0407407UC	4F0408903UC	1	

2006 & OLDER
 DRIVE SHAFT & SLIP CLUTCH
 ECONOMY & MEDIUM DUTY CUTTERS

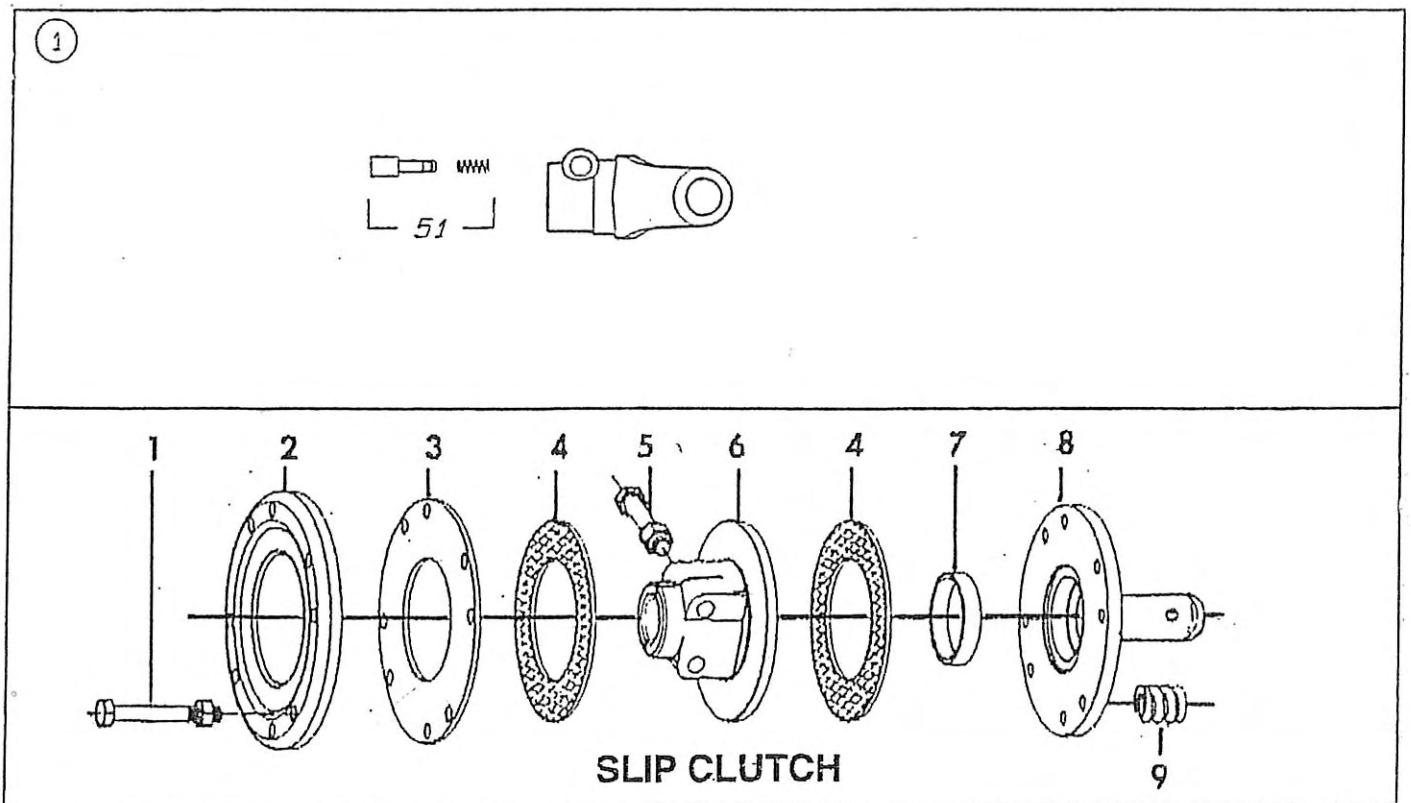
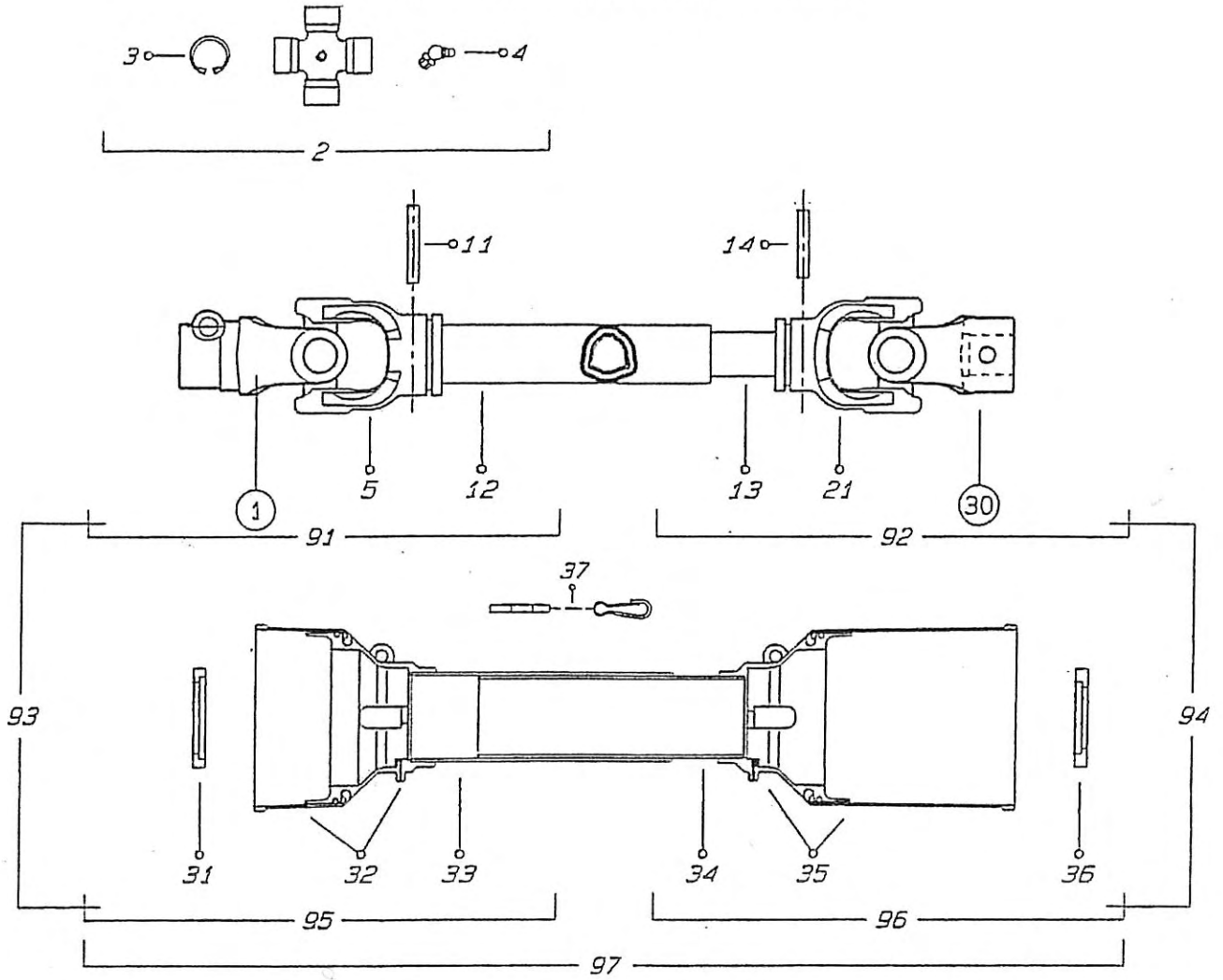

2006 & OLDER
DRIVE SHAFT & SLIP CLUTCH
ECONOMY, ROUND BACK & MEDIUM DUTY CUTTERS

REF. NO	40" & 4' PART NO.	5' PART NO.	6' PART NO.	DESCRIPTION
1	0800403	SAME - 4'	SAME - 4'	YOKE
2	08204	SAME - 4'	SAME - 4'	CROSS JOURNAL ASSY.
3	09802027	SAME - 4'	SAME - 4'	CIRCLIP
4	09840081002	SAME - 4'	SAME - 4'	GREASE FITTING
5	08004021	SAME - 4'	SAME - 4'	OUTER TUBE YOKE
11	098700860	SAME - 4'	SAME - 4'	FLEXIBLE PIN
12	09881433470	09881433600	09881433740	CM. CARDAN TUBE
13	09881364470	09881364600	09881364740	CM. CARDAN TUBE
14	098700855	SAME - 4'	SAME - 4'	FLEXIBLE PIN
21	08004011	SAME - 4'	SAME - 4'	INNER TUBE YOKE
30	0800401K60	SAME - 4'	080401K60	YOKE
31	0265140005	SAME - 4'	SAME - 4'	O . BEARING 4
32	0256040324	SAME - 4'	SAME - 4'	O . BASIC CONES B4
33	0988966B4083	0988966B4096	0988966B4110	CM. SAFETY TUBE
34	0988961B4083	0988961B4096	0988961B4110	CM. SAFETY TUBE
35	0256040325L	SAME - 4'	SAME - 4'	I . BASIC CONES B4
36	0265140006	SAME - 4'	SAME - 4'	I. BEARING 4
37	0252000001	SAME - 4'	SAME - 4'	CHAINS
51	0986014047	SAME - 4'	SAME - 4'	COMPLETE PUSH BUTTON
91	B408302	B409602	B411002	HALF SHAFT
92	B408301K60	B409601L60	B411001K60	HALF SHAFT
93	B4083E2	B4096E2	B4110E2	HALF SHAFT
94	B4083E1K60	B4096E1K60	B4110E1K60	HALF SHAFT
95	083E040832	083E040962	083E041102	HALF SAFETY GUARD
96	083E040831L	083E040961L	083E041101L	HALF SAFETY GUARD
97	083E04083L	083E04096L	083E04110L	SAFETY GUARD

SLIP CLUTCH

REF.	P/N	DESCRIPTION
1	1341080	BOLT W/NUT 10 MM X 80 MM
	3371080	BOLT ONLY 10 MM X 80 MM
	3660010	NUT
2	1135007	PRESSURE PLATE - OUTER
3	1135008	PRESSURE PLATE - INNER 180 MM
4	1805010	FRICITION DISK - 140 MM
5	1341270	BOLT, W/NUT & WASHER
	3371270	BOLT ONLY 12 MM X 70 MM
	3970012	LOCK WASHER 12 MM
	3560012	NUT, 12 MM
6	1706308	HUB, SMOOTH 1-3/8"
7	1705009	SLEEVE
8	1706309	FLANGE, W/ SMOOTH SHAFT
9	1215012	TENSION SPRING

DRIVE SHAFT HEAVY DUTY CUTTERS

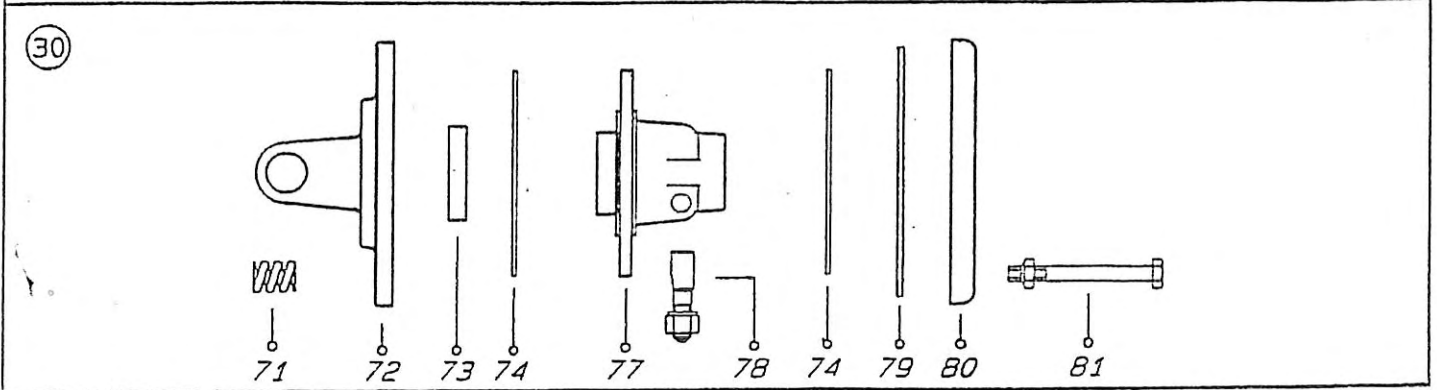
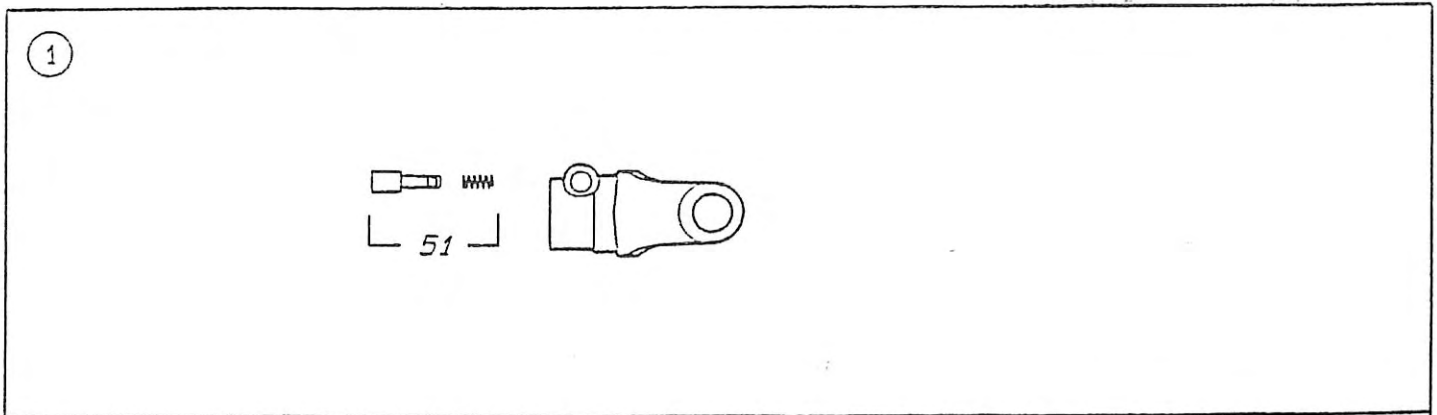
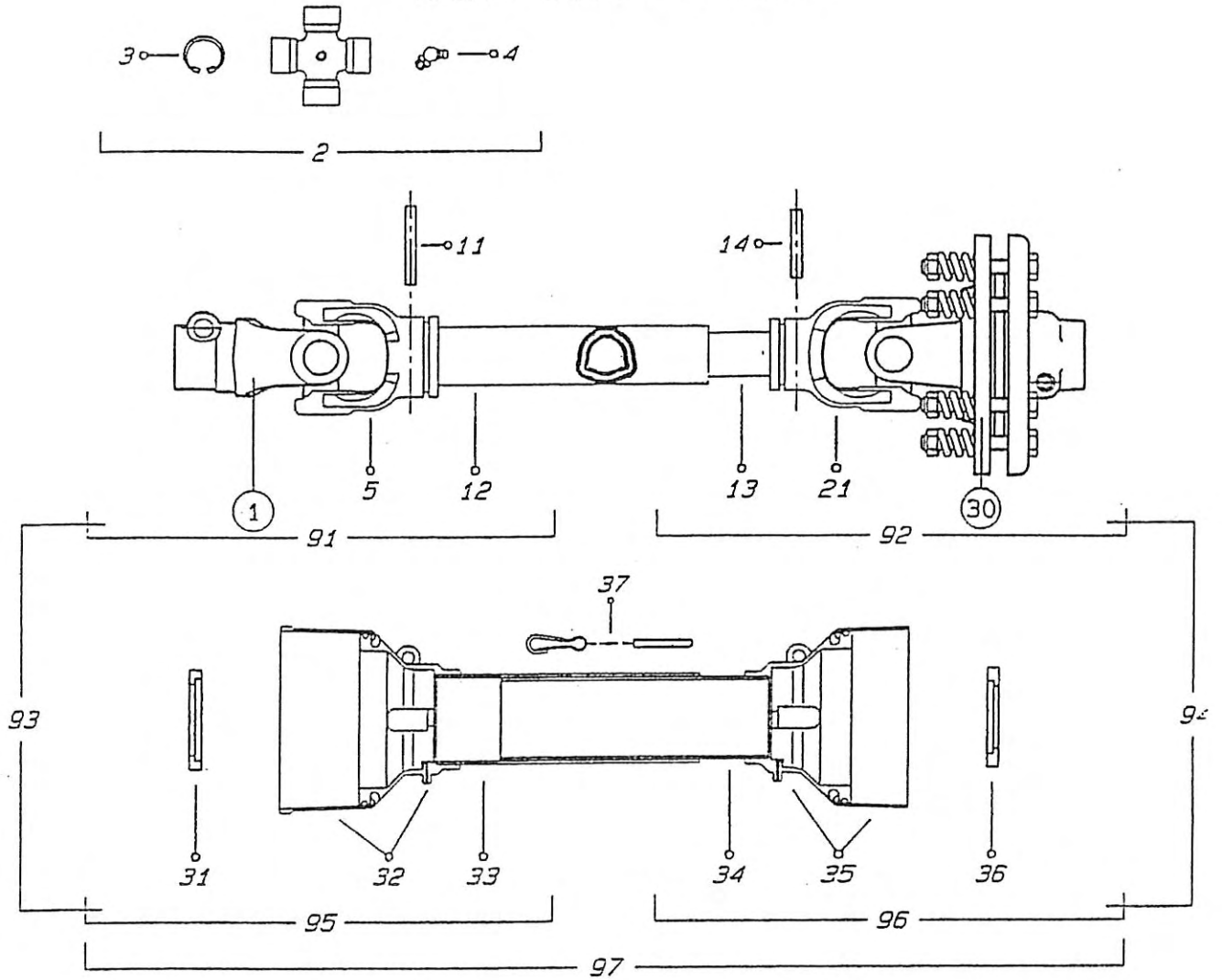

**DRIVE SHAFT
HEAVY DUTY CUTTERS**

REF.	P/N-5'	P/N-6'	P/N-7'	DESCRIPTION
1	0800503	SAME-5'	0800603	QUICK RELEASE YOKE
2	08205	SAME-5'	08206	CROSS JOURNAL SET
3	099802030	SAME-5'	SAME-5'	CIRCLIP
4	099840081002	SAME-5'	SAME-5'	GREASE NIPPLE
5	08005021	SAME-5'	08006021	OUTER TUBE YOKE
11	098700870	SAME-5'	098701080	FLEXIBLE PIN OUTER TUBE
12	09881523100	SAME-5'	09881544100	OUTER CARDAN TUBE
13	09881454100	SAME-5'	SAME-5'	INNER CARDAN TUBE
14	098700865	SAME-5'	098701070	FLEXIBLE PIN INNER TUBE
21	08005011	SAME-5'	0800611	INNER TUBE YOKE
30	086205	SAME-5'	086206	FRICITION CLUTCH
31	0265250005	0265050005	0265260005	OUTER BEARING
32	0256050324	SAME-5'	SAME-5'	OUTER BASIC CONE
33	0988981B5094	0988981B5110	0988981B6133	OUTER SAFETY TUBE
34	0988975B5094	0988975B511	0988975B6133	INNER SAFETY TUBE
35	0256050325C	SAME-5'	SAME-5'	INNER SHORT CONE
36	0265250006	0265050006	0265260006	INNER BEARING
37	025200001	SAME-5'	SAME-5'	CHAIN
51	0986014047	SAME-5'	SAME-5'	COMPLETE PUSH BUTTON
71	09845257033	SAME-5'	SAME-5'	SPRING
72	086920105	SAME-5'	086920106	FLANGE YOKE
73	0981554125	SAME-5'	SAME-5'	BUSH
74	09833160	SAME-5'	SAME-5'	LINING
77	0869207060	SAME-5'	SAME-5'	HUB
78	0408000029	SAME-5'	SAME-5'	CONIC SCREW
79	0869219	SAME-5'	0869112	INNER PLATE
80	0869212	SAME-5'	SAME-5'	PRESSURE PLATE
81	099510085B	SAME-5'	SAME-5'	SCREW AND NUT
91	B509402	B511002	B613302	OUTER HALF SHAFT (W/O GAURD)
92	B509401255	B511001255	B613301255	INNER HALF SHAFT (W/O GAURD)
93	B5094E2	B5110E2	B6133E2	OUTER HALF SHAFT (WITH GAURD)
94	B5094E1255	B5110E1255	B6133E1255	INNER HALF SHAFT (WITH GAURD)
95	083E050942	083E051102	083E061332	OUTER HALF GAURD
96	083E050941C	083E051101C	083E061331C	INNER HALF SHORT GAURD
97	083E05094SC	083E05110SC	083E06133SC	COMPLETE GAURD