



Tebben Enterprises - 10009 Highway 7 SE - Clara City, Minnesota 56222

Tel: (320)847-2200

Fax: (320)847-3112

# OPERATOR'S MANUAL AUTOMATIC RESET DEEP TILL & TRASH CUTTER



PART NO. TM76-02

## WARRANTY

**Tebben Enterprises of Clara City, Minnesota 56222**, warrants that its products and their components will be free from defects in material and workmanship for a period of one (1) year from the date of original purchase when used as intended and under normal service and conditions. This warranty is limited to the replacement of any defective part by **Tebben Enterprises**, provided that any such defective part must be returned to **Tebben Enterprises**, TRANSPORTATION PREPAID, accompanied by a letter setting forth the nature of the defect. If the part is found to be defective by reason of materials or workmanship, **Tebben Enterprises**, shall replace the part, but shall not be responsible for its re-installation.

This Warranty does not cover or apply to any products or component parts which have been tampered with, modified or altered in any way or which have been subject to misuse, negligence, involved in an accident, or damaged by an act of God.

## EXCLUSION OF WARRANTIES

TEBBEN ENTERPRISES MAKES NO WARRANTIES OF MERCHANTABILITY OR FITNESS FOR ANY PARTICULAR PURPOSE IN RESPECT TO ITS PRODUCTS OR COMPONENT PARTS. TEBBEN ENTERPRISES SHALL NOT BE LIABLE FOR ANY CONSEQUENTIAL OR INCIDENTAL DAMAGES FROM ANY BREACH OF WARRANTY, INCLUDING, BUT NOT LIMITED TO, LOSS OF PROFITS, INCONVENIENCE, AND THE COST OF RENTAL OR REPLACEMENT EQUIPMENT. NO AGENT, EMPLOYEE OR REPRESENTATIVE OF TEBBEN ENTERPRISES HAS THE AUTHORITY TO BIND IT TO ANY AFFIRMATION, STATEMENT OR WARRANTY CONCERNING ITS PRODUCTS AND THEIR COMPONENT PARTS EXCEPT AS SPECIFICALLY SET FORTH HEREIN.

BE SURE THE MACHINE IS RAISED ALL THE WAY OUT OF THE GROUND BEFORE TURNING.  
WARRANTY VOID IF NOT DONE PROPERLY.



R.R.2, BOX 140 WEST HWY. 7 CLARA CITY, MINN. 56222  
(612) 847-3512 OR (612) 847-2200  
FAX (612) 847-3112

# TABLE OF CONTENTS

SAFETY RULES .....	1-3
OPERATION.....	4-6
ASSEMBLY INSTRUCTIONS.....	9-11
ASSEMBLY (OPTIONAL EQUIPMENT).....	12-14
HYDRAULIC SYSTEM.....	15-17
SHANK SPACING.....	18-21
DECAL LISTING.....	22
MAIN FRAME ASSEMBLY PARTS BREAKDOWN.....	23-24
SINGLE FRAME ASSEMBLY PARTS BREAKDOWN.....	25-26
TRASH CUTTER FRAME ASSEMBLY PARTS BREAKDOWN.....	27-28
DISK SPRING ASSEMBLY PARTS BREAKDOWN.....	29-30
SPRING COULTER ASSEMBLY PARTS BREAKDOWN.....	30-31
SHANK ASSEMBLY (1979-1983), (1976-1978).....	32-33
SHANK ASSEMBLY (1984, 1985-1989).....	34-35
SHANK ASSEMBLY (1990 & NEWER).....	36-37
RIDGE RIPPER PARTS BREAKDOWN.....	38-39
POLE HITCH PARTS BREAKDOWN.....	40
EXTENSIONS & 7 SHANK 24" FRAME CONVERSION KIT.....	41
LEVELATOR.....	42-43
WELDED HYDRAULIC CYLINDERS (1976-1989).....	44
TIE ROD HYDRAULIC CYLINDERS (1990-1994).....	45
TIE ROD HYDRAULIC CYLINDERS (1995 & NEWER).....	46
DISC LEVELER.....	47



# SAFETY

## SAFETY ALERT SYMBOL

This Safety Alert symbol means **ATTENTION! BECOME ALERT! YOUR SAFETY IS INVOLVED!**



The Safety Alert symbol identifies important safety messages on the implement and in the manual. When you see this symbol, be alert to the possibility of personal injury or death. Follow the instructions in the safety message.

### SIGNAL WORDS:

Note the use of the signal words **DANGER**, **WARNING** and **CAUTION** with the safety messages. The appropriate signal word for each message has been selected using the following guide-lines:

### SAFETY

**YOU** are responsible for the **SAFE** operation and maintenance of your implement. **YOU** must ensure that you and anyone else who is going to operate, maintain or work around the implement be familiar with the operating and maintenance procedures and related **SAFETY** information contained in this manual. This manual will take you step-by-step through your working day and alerts you to all good safety practices that should be adhered to while operating this equipment.

Remember, **YOU** are the key to safety. Good safety practices not only protect you but also the people around you. Make these practices a working part of your safety program. Be certain that **EVERYONE** operating this equipment is familiar with the recommended operating and maintenance procedures and follows all the safety precautions. Most accidents can be prevented. Do not risk injury or death by ignoring good safety practices.

- Implement owners must give operating instructions to operators or employees before allowing them to operate the implement, and at least annually thereafter per OSHA regulation 1928.57.
- The most important safety device on this equipment is a **SAFE** operator. It is the operator's responsibility to read and understand **ALL** Safety and Operating instructions in the manual and to follow these. All accidents can be avoided.
- A person who has not read and understood all operating and safety instructions is not qualified to operate the machine. An untrained operator exposes themselves and bystanders to possible serious injury or death.
- Do not modify the equipment in any way. Unauthorized modification may impair the function and/or safety and could affect the life of the equipment.
- Think **SAFETY!** Work **SAFELY!**

**DANGER** - An immediate and specific hazard which **WILL** result in severe personal injury or death if the proper precautions are not taken.

**WARNING** - A specific hazard or unsafe practice which **COULD** result in severe personal injury or death if proper precautions are not taken.

**CAUTION** - Unsafe practices which could result in personal injury if proper practices are not taken, or as a reminder of good safety practices.

### GENERAL SAFETY

1. Read and understand the Operator's Manual and all safety signs before operating, maintaining or adjusting the implement.



2. Install and properly secure all shields and guards before operating.

3. Have a first-aid kit available for use should the need arise and know how to use it.



4. Have a fire extinguisher available for use should the need arise and know how to use it.



5. Clear the area of people and remove foreign objects from the machine before starting and operating.

6. Stop tractor engine, disengage PTO clutch, set park brake, remove ignition key and wait for all moving parts to stop before servicing, adjusting, repairing or unplugging.

7. Review safety related items with all operators annually.

8. Wear suitable ear protection for prolonged exposure to excessive noise.



## OPERATING SAFETY

1. Read and understand the Operator's Manual and all safety signs before operating, servicing, adjusting or unplugging.
2. Do not allow riders on the implement or tractor during field operation or transport.
3. Keep hands, feet, hair and clothing away from all moving and/or rotating parts.
4. Stop tractor engine, place hydraulic controls in neutral, set park brake, remove ignition key and wait for all moving parts to stop before servicing, adjusting, repairing or unplugging.
5. Ensure that all tractor controls are in neutral before starting.
6. Clear the area of all bystanders, especially children, before starting.
7. Be careful when working around or maintaining a high-pressure hydraulic system. Wear proper eye and hand protection when searching for a high pressure leak. Use a piece of wood or cardboard as a backstop when searching for a pin hole leak in a hose or line.
8. Before applying pressure to the hydraulic system, make sure all components are tight and that hoses and couplings are not damaged.
9. Stay away from overhead obstructions and power lines during set-up and operation. Electrocutation can occur without direct contact.
10. Review all safety instructions annually.

## TRANSPORT SAFETY

1. Read and understand ALL the information in the Operator's Manual regarding procedures and SAFETY when operating the implement in the field or on the road.
2. Make sure the SMV (Slow Moving Vehicle) emblem and all the lights and reflectors that are required by the local highway and transport authorities are in place, are clean and can be seen clearly by all overtaking and oncoming traffic.
3. Do not allow riders on any part of the machine during either field operation or road and highway travel.
4. Always use hazard warning flashers on tractor when transporting unless prohibited by law.

## MAINTENANCE SAFETY

1. Review the Operator's Manual and all related Maintenance, Operating and SAFETY information annually with all personnel who will be working with, maintaining or operating the implement.
  2. Stop tractor engine, place hydraulic controls in neutral, set park brake, remove ignition key before servicing, adjusting, repairing or unplugging.
  3. Be careful when working around or maintaining a high-pressure hydraulic system. Wear proper eye and hand protection when searching for a high pressure hydraulic leak. Use a piece of wood or cardboard as a backstop when searching for a pin hole leak in a hose or steel line.
  4. Before applying pressure to a hydraulic system, make sure all components are tight and that steel lines, hoses and couplings are not damaged.
  5. Seek immediate medical attention if a high-pressure concentrated stream of hydraulic fluid pierces the skin, as toxic reaction and infection could develop.
  6. Keep hands, feet, clothing and hair away from all moving and/or rotating parts.
  7. Clear the area of all bystanders, especially children, when carrying out any maintenance or making adjustments on the systems of components.
  8. Place stands or blocks under the frame before working beneath the machine.
- Think SAFETY! Work SAFELY!

## HYDRAULIC SAFETY

1. Always place all tractor hydraulic controls in neutral before dismounting.
  2. Make sure that all components in the hydraulic system are kept in good condition and are clean.
  3. Replace any worn, cut, abraded, flattened or crimped hoses and metal lines.
  4. Do not attempt any makeshift repairs to the hydraulic lines, fittings or hoses by using tape, clamps or cements. The hydraulic system operates under extremely high-pressure. Such repairs will fail suddenly and create a hazardous and unsafe condition.
  5. Wear proper hand and eye protection when searching for a high-pressure hydraulic leak. Use a piece of wood or cardboard as a backstop instead of hands to isolate and identify a leak.
  6. If injured by a concentrated high-pressure stream of hydraulic fluid, seek medical attention immediately. Serious infection or toxic reaction can develop from hydraulic fluid piercing the skin surface.
  7. Before applying pressure to the system, make sure all components are tight and that lines, hoses and couplings are not damaged.
- Think SAFETY! Work SAFELY!

## STORAGE SAFETY

1. Store the unit in an area away from human activity.
2. Do not permit children to play around the stored unit.

## TIRE SAFETY

1. Failure to follow proper procedures when mounting a tire on a wheel or rim can produce an explosion which may result in serious injury or death.
2. Do not attempt to mount a tire unless you have the proper equipment and experience to do the job.
3. Have a qualified tire dealer or repair service perform required tire maintenance.

# OPERATION

## TO THE NEW OPERATOR OR OWNER

Read this manual carefully to learn how to operate the machine safely and how to set it to provide maximum field efficiency. The manual will take you step-by-step through your working day. By following the operating instructions in conjunction with a good maintenance program, your implement will provide many years of trouble-free service.



### OPERATING SAFETY

1. Read and understand the Operator's Manual and all safety signs before operating, servicing, adjusting, or unplugging.
2. Do not allow riders on the tractor.
3. Install and secure all guards and shields before starting or operating.
4. Keep hands, feet, hair and clothing away from all moving and/or rotating parts.
5. Stop tractor engine, place hydraulic controls in neutral, set park brake, remove ignition key and wait for all moving parts to stop before servicing, adjusting, repairing or unplugging.
6. Ensure that all tractor controls are in neutral before starting.
7. Clear the area of all bystanders, especially children, before starting.
8. Be careful when working around or maintaining a high-pressure hydraulic system. Wear proper eye and hand protection when searching for a leak. Use a piece of wood or cardboard as a backstop.
9. Stay away from overhead obstructions and power lines during set-up and operation.

## ATTACHMENT TO TRACTOR

The implement should always be parked on a level, dry area that is free of debris and foreign objects. Follow this procedure when attaching.

1. Clear the area of bystanders and remove foreign objects from the machine and working area.
2. Make sure there is enough room to back the tractor up to the hitch point.
3. Start the tractor and slowly back it up to the hitch point.
4. Stop the tractor engine, place all controls in neutral, set park brake and remove ignition key before dismounting.
5. The hydraulics should be connected. To connect, proceed as follows:

- a. Use a clean cloth or paper towel to clean the couplers on the ends of the hoses. Also clean area around the couplers on the tractor.

### IMPORTANT

Always exercise extreme care and cleanliness when connecting and operating a hydraulic system. Contaminants introduced into the system due to carelessness can cause rapid wear of internal components and possible system failure.

- b. Remove the plastic plugs from the couplers and insert the male ends. Be sure to match the high and return pressure lines to one valve bank.
- c. Connect the remaining couplers. Be sure to match the system with the desired control lever on the tractor.

### NOTE

If the direction of motion is wrong, reverse the coupler connections or operate the control lever in the opposite direction.

## How The Automatic Reset Leaf Spring Works

LEAF SPRING REDUCES IMPACT  
PRESSURE — MINIMIZES BREAKAGE

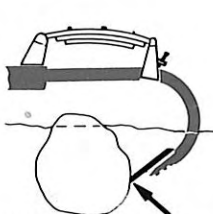

POINT PRESSURE-1500 LBS.

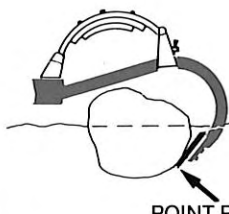

POINT PRESSURE  
ONLY 1100 LBS. (APPROX.)

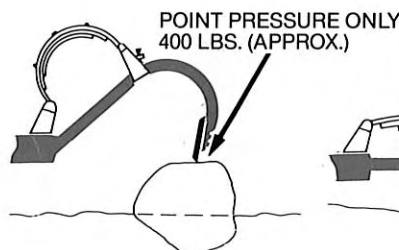

POINT PRESSURE ONLY  
400 LBS. (APPROX.)

SPRING LEAVES  
CAN BE ADDED TO  
INCREASE POINT PRESSURE  
FOR HEAVIER LAND  
WITH ADEQUATE  
HORSEPOWER

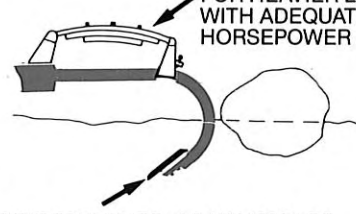

POINT PRESSURE-AGAIN 1500 LBS.



# OPERATION AND SERVICE

## TRACTOR PREPARATION

The rear tractor tires should be inflated and ballast added according to the tractor operators manual. The tractor drawbar should be locked in the center position for road transport but free to swing during field operation. Check the tractor hydraulic oil reservoir and add oil as required.

## IMPLEMENT PREPARATION

To hitch your tractor to the deep till, use the following procedure:

"Carefully" back your tractor into place and attach the clevis to drawbar. Use the correct size drawpin for the clevis.

Clean all hydraulic couplings and connect to the tractor couplings. **NOTE: Use all one style tractor couplings to prevent system lock up.** The deep till should "raise" when the hydraulic lever is moved "forward" and "lower" when moved "back".

Before raising and lowering the deep till be certain that the lift cylinders are functioning properly, fittings are not leaking, and there is no air left in the hydraulic system.

## CHARGING THE HYDRAULIC SYSTEM

**IMPORTANT:** When first using or transporting the deep till, it is necessary to charge the hydraulic lines and cylinders with approximately five to ten gallons of hydraulic oil as follows:

A) Charging a new deep till which has not been previously charged with hydraulic oil.

- 1) Charge the wheel cylinders by holding the tractor hydraulic lever rearward until the unit raises up on its wheels. (Note: This is a slave hydraulic system. It is necessary to hold the tractor lever rearward for 30-60 seconds to allow oil to flow through the complete system.) Lower the unit by moving hydraulic level forward. Repeat this procedure several times to insure the slave system is purged of air. Check the tractor hydraulic reservoir and add oil as required.

B) Recharging the hydraulic system of a machine which has been previously charged but has been in storage or disconnected from the tractor.

- 1) Raise the unit onto its wheels and hold the tractor hydraulic lever rearward for 30-60 seconds to purge the slave system of air.



**CAUTION:** All hydraulically or mechanically elevated components must be blocked to prevent accidental lowering or must be lowered to the ground when adjustments or repairs are made or when not in use.

## IMPLEMENT TRANSPORT

Prior to transporting the deep till, the wheel cylinders should be recharged, and the transport safety locks installed as follows. The tractor operator himself should perform the locking operations and he should be the only person in the tractor cab or around the unit for safety. Begin by raising the unit on its wheels and holding the tractor hydraulic lever rearward for 30-60 seconds to purge air from the slave system. Install the main axle safety locks.

**NOTE:** Never transport a trail type implement with the tractor drawbar free to swing.

**IMPORTANT:** Prior to transporting the unit always check wheel lug bolt tightness. Lug bolts should be torqued to 85-90 ft/lbs. When unit is new, the lug bolts should be retorqued every 4 or 5 miles or road transport until they are properly seated.



**ALWAYS COMPLY WITH ALL STATE, FEDERAL AND LOCAL LAWS WHEN TRANSPORTING THE FIELD CULTIVATOR ON THE PUBLIC ROADWAYS.**

**DRIVE AT REASONABLE SPEEDS TO INSURE YOUR SAFETY. SLOW DOWN BEFORE MAKING SHARP TURNS OR USING THE BRAKES. DRIVE SLOWLY OVER ROUGH GROUND, SIDE HILLS, AND AROUND CURVES TO AVOID TIPPING.**

## S.M.V. SYMBOL

The SMV bracket (Slow Moving Vehicle) is a recommended attachment that must be added to your deep till. Check state and local laws regarding the placement and use. When transporting over public roadways, the SMV symbol must be used for protection of both the tractor and motor vehicle operators.

USE THE SMV (SLOW MOVING VEHICLE) EMBLEM FOR WARNING VEHICLES APPROACHING FROM THE REAR. PROTECT THE SMV SYMBOL AND KEEP IT CLEAN.

## CYLINDER TRANSPORT LOCK AND DEPTH CONTROL

**Transport Locks:** To lock in transport position, extend cylinders and place transport lock over cylinder rod. Lock in place with cotter pin and hairpin.

**Depth Control:** One set of donut type Depth Stops are provided for each machine. One set equals 4 different length stops. Depth stops must be placed on the #1 cylinder. The #1 cylinder is the master and the other cylinders do not need them. When your Deep Till has more than 2 cylinders, 2 sets of stops will be provided. These should be placed on the #1 cylinder and also on the opposite end cylinder to provide assured depth control.

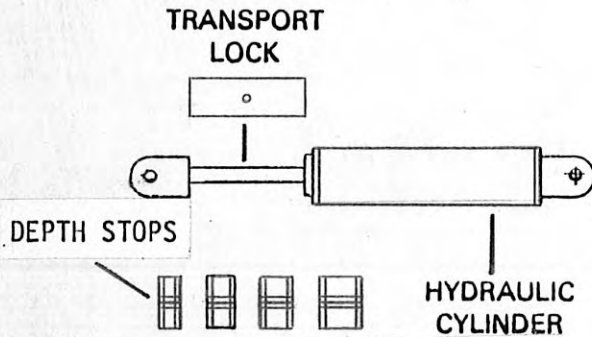

Determine operating depth and use stops accordingly.

### FIELD OPERATION

**INSTRUCT ALL OPERATORS OF THE PROPER AND SAFE OPERATION OF THE MACHINE. REVIEW THE OPERATOR'S MANUAL FOR CORRECT PROCEDURES.**

### POLE HITCH OPERATION

In preparation for field use the transport safety locks must be disengaged. The tractor operator himself should perform the disengaging of the transport safety locks. For safety, the tractor operator should be the only person around the field cultivator or in the tractor cab. First move the tractor lever which controls the axle cylinders rearward to fully extend those cylinders and relieve the transport lock pins so they may be easily removed.

Move the hydraulic lever to lower the cultivator to the ground until teeth are running at the desired depth. Adjust the hitch so the frame is parallel with the ground and all teeth are cutting the same depth. Select proper speed (3½ to 5 MPH) for best results.

**NOTE:** The axles are synchronized for raising and lowering the unit when the system is charged with oil. Should the axles become irregular in depth in field operation causing uneven depth of tillage, raise the unit and hold the tractor hydraulic lever until all axle lift cylinders are fully extended. This will return the axle cylinders to their proper synchronization.

Speed should be reduced at the ends of the field and when turning. Do not make high speed turns at anytime, either in the field or in transport.

**NOTE:** When pulling this implement in the field, always allow the tractor drawbar to swing free.

**NOTE:** Always raise the deep till completely out of the ground when making turns in operation.

### 3 PT. HITCH OPERATION

Lower the chisel plow into the ground and pull it a few feet at the approximate depth. Check the frame for levelness from front to rear. Level the frame on 3 pt. models by adjusting the upper linkage until all teeth are cutting level.

Set the depth by adjusting the gauge wheels on the chisel plow. The gauge wheels should apply a slight pressure against the soil.



**CAUTION: NEVER ALLOW ANYONE TO RIDE ON THE DEEP TILL.**

It is important to keep all bolts tight at all times. Check them frequently during the first few hours of operation. After break-in period, check them periodically.

### LUBRICATION

Proper lubrication of moving parts is essential in maintaining the proper operation of the deep till. Carry out the following procedures to insure proper lubrication.

1. Repack all wheel bearings once a year with a lithium base grease.
2. Inspect all bearing seals for cracks or signs of wear. Replace seals that are not in good order.
3. Lubricate the axle bearings daily with a lithium base grease.
4. Lubricate the shank assembly daily with a lithium base grease.

# ASSEMBLY

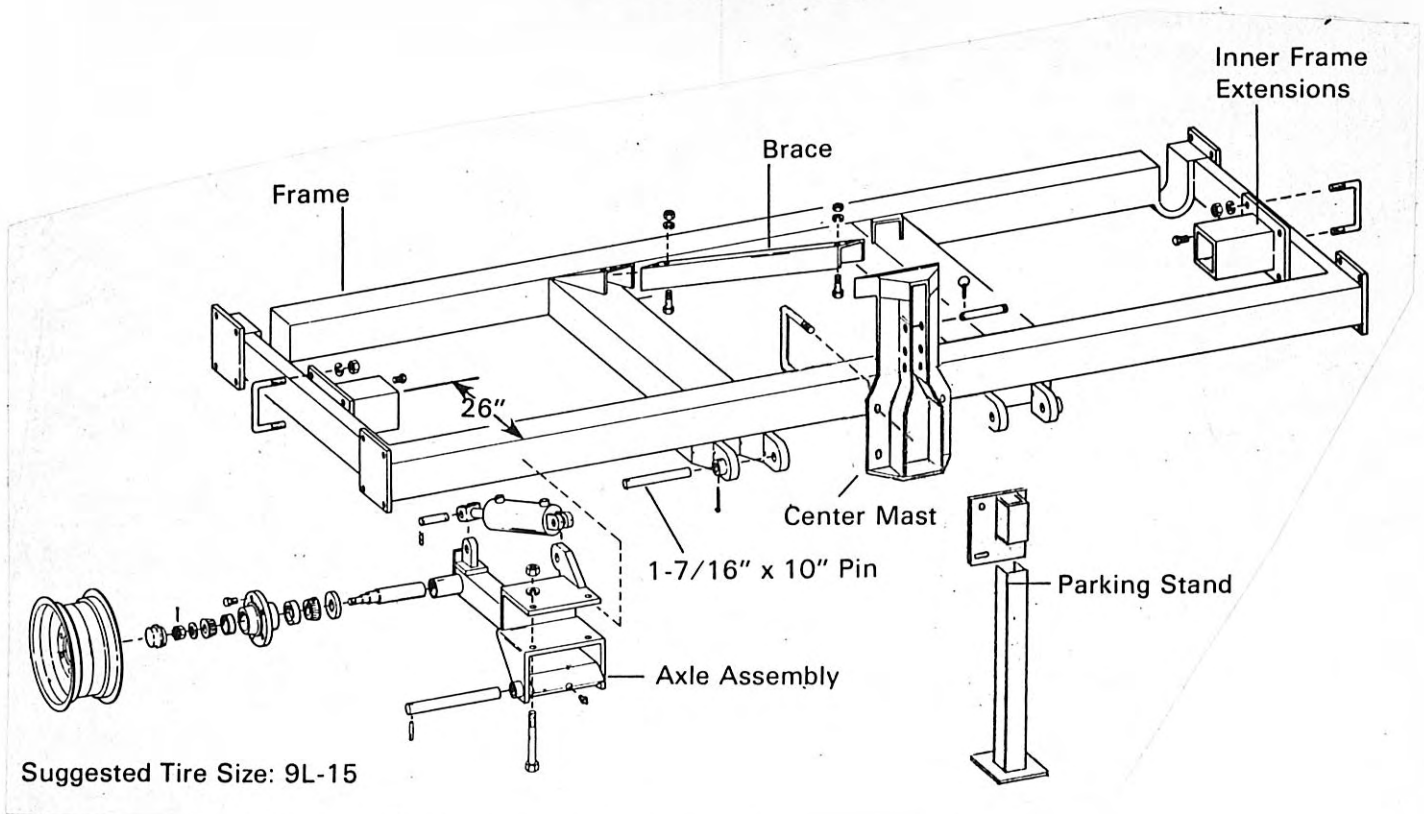

## MAIN FRAME ASSEMBLY

Set the frame on stands for ease in assembly. Assembly should be carried out in an open and flat area.

Locate the center of the chisel plow frame and mark it. Assemble the center mast over the center mark. Loosely attach the center mast to the frame using  $2\frac{3}{4}$ " x  $8\frac{1}{2}$ " x 5 x  $8\frac{1}{2}$ " bolts, lock washers and nuts. On the left side of the center mast attach the parking stand using the center mast u-bolts. Do not tighten bolts yet.

**NOTE:** The right and left hand side of the unit is designated when facing the direction of travel when in operation.

Assemble the center mast braces to the main frame and center mast using four  $\frac{5}{8}$ " x  $1\frac{1}{2}$ " carriage bolts, lock washers, and nuts. Repeat for the other brace. Tighten all bolts at this time.

For 15" Spacing Models

Mount the inside frame extensions to the end bars of the frame as shown. The shank mounting tube should be 26" from the front frame member to the front of the mounting tube.

Assemble the axle mounting bracket to the front frame member. Loosely bolt in place with two  $\frac{3}{4}$ " x 7" bolts, lock washers and nuts. Mount the rim to the axle hub. Refer to the shank spacing chart as to location of the wheels. Mount the wheels within  $\frac{1}{4}$ " of the frame and the extensions as shown in shank spacing chart.



## SINGLE BEAM FRAME ASSEMBLY 3, 5, 7 SHANK

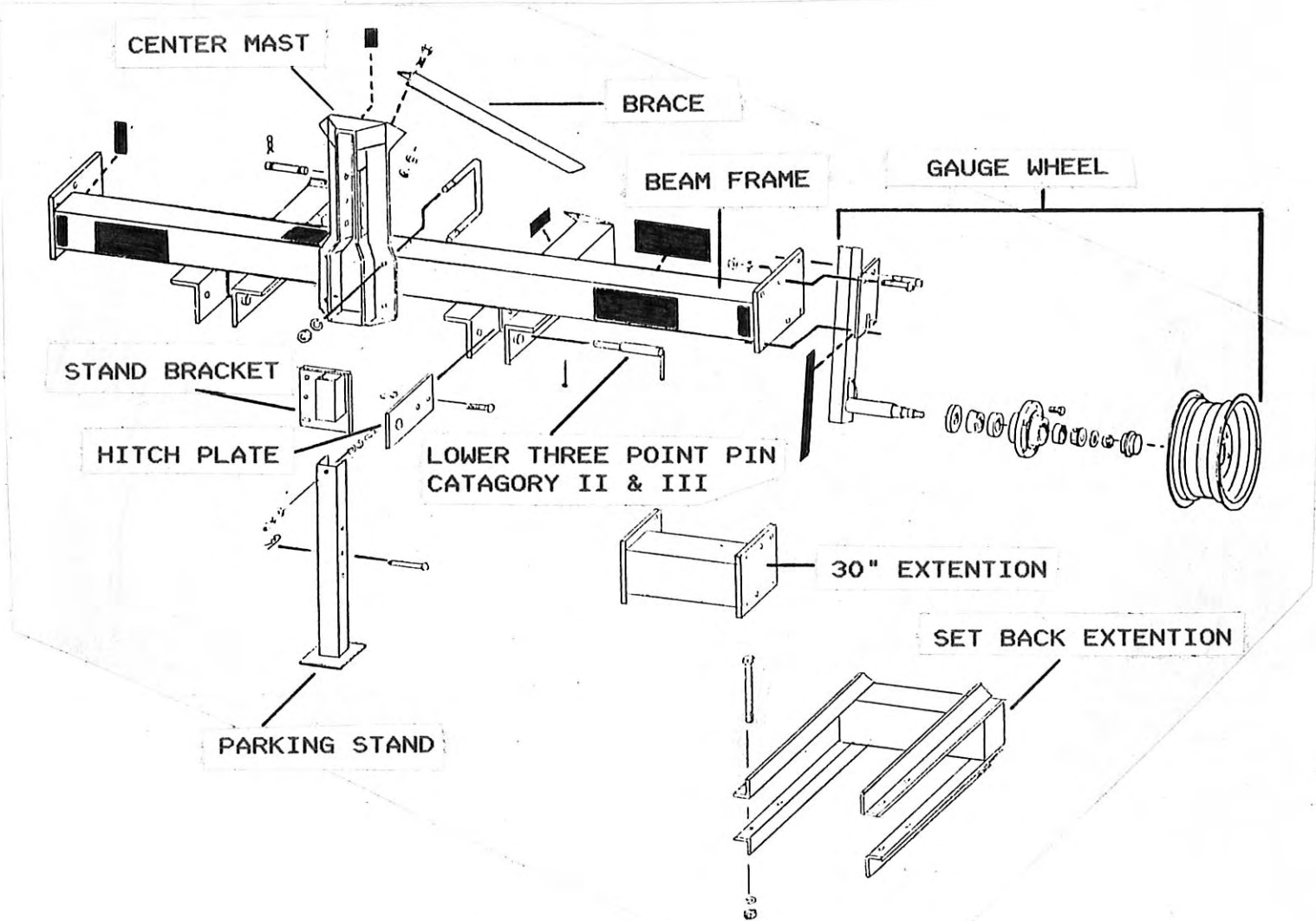

Set the beam frame on stands, 7" side on bottom, for ease in assembly. Assembly should be carried out in an open area.

Locate the center of the beam and mark it. Mount the center mast over the center mark. Attach center mast to beam using four 3/4" x 4" hex bolts, lock washers and nuts. On the left side of the center mast mount the parking stand using the center mast u-bolt. Do not tighten bolts securely.

Assemble the center mast braces to the center mast and beam using 5/8" x 1-1/2" bolts, lock washers and nuts. Tighten all bolts at this time.

Mount the gauge wheels to the end of the beam as shown using 5/8" x 3-1/2" x 3" x 3-1/2" u-bolts and lock washers and nuts. Mount the rims to the axle hubs. Suggested tire size is 6.70 x 15.

Assemble the shank assemblies to the frame as needed for your spacing. Single beam shank spacings are 20" or 30".

When used, mount the set-back extension to frame as shown. One set-back extension behind each center mast brace.

## TRASH CUTTER ASSEMBLY

When mounting trash cutter to single beam frame, first remove the center mast and center mast braces from single beam. You will use the center mast on the trash cutter frame.

Assemble the trash cutter frame to the single beam frame using  $3/4"$  x  $2"$  bolts, lockwashers and nuts. Position the center frame mount between frames as shown. Use  $3/4"$  U-bolts to mount and place the center mast in front of the brace using  $3/4"$  x  $9-1/2"$  bolts to mount.

Attach the center mast braces, left and right, to the center mast and to single beam frame using  $5/8"$  x  $1-1/2"$  bolts to mount. You will have to drive the rear mounting brace down to attach the rear of the mast brace to mounting brace.

Slide the disk gang under the frame as shown. Slide brackets into disk gang frame tube. Mount brackets to trash cutter frame using  $3/4"$  U-bolts. Repeat for other side. Attach the spring leaf group to frame with a  $3/4"$  x  $8"$  bolt and nut. Connect the rear of the spring leaf group to disk frame arm, using  $5/8"$  x  $8-1/2"$  bolt and nut to secure.

Adjust the spring leaf camber by turning adjusting bolts up or down until the center of bolt to center of bolt is  $27"$ . Set the blade depth at  $3"$  by turning the adjusting bolt.

Mount the gauge wheel to the end of the beam using  $5/8"$  x  $3-1/2"$  x  $3"$  x  $3-1/2"$  U-bolts, lockwashers and nuts. Mount the rims to axle hubs. Suggested tire size is  $6.70$  x  $15$ .

Assemble extension to the trash cutter frame with  $3/4"$  x  $2"$  bolts. Assemble the disk group as before.

**CAUTION**



**USE  $5/8"$  LOCKNUTS. DO NOT TIGHTEN SPRING HOLDER CLEVIS TIGHTLY TO SPRING FOR SPRING MUST MOVE FREELY.**

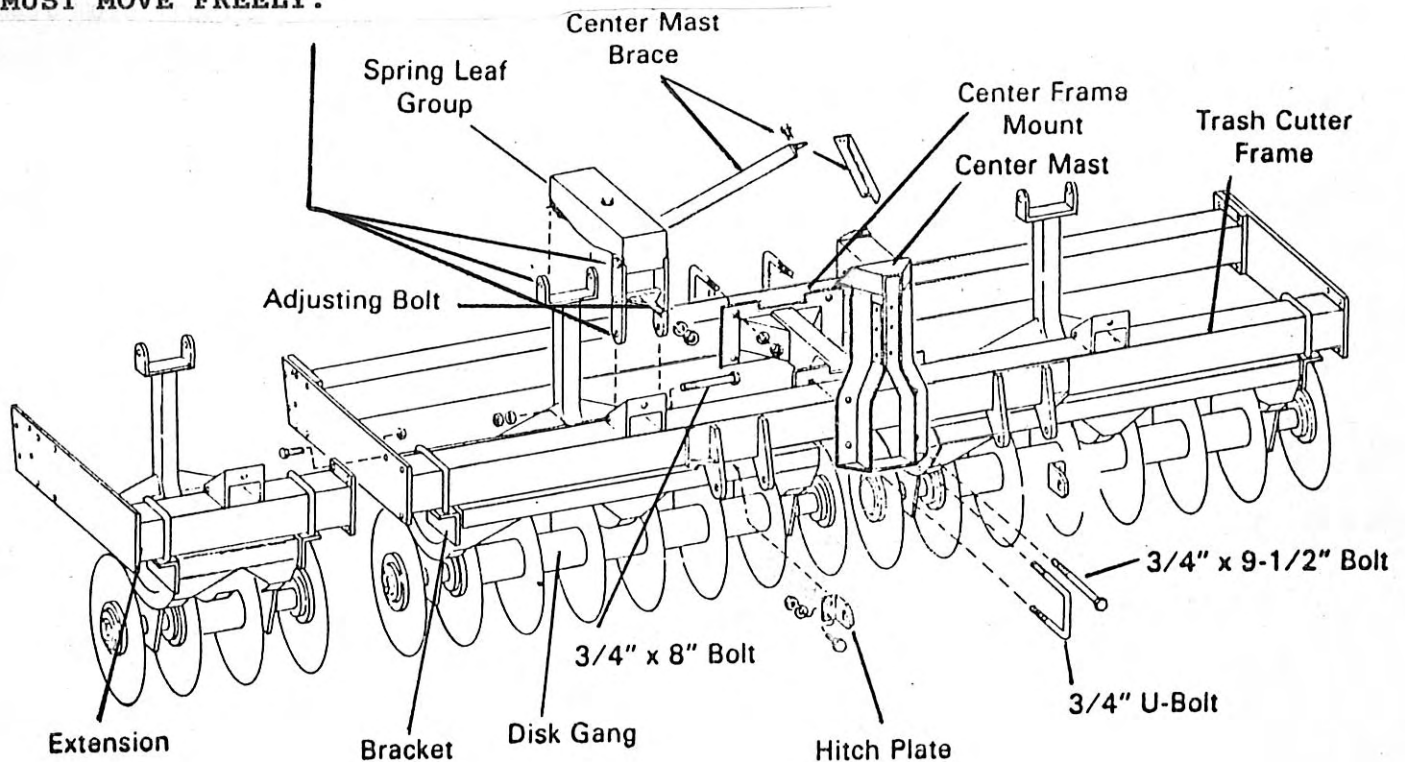

Mount Cat. II & III hitch plate to plate between hitch arms, using  $5/8"$  x  $1-1/2"$  bolts, lockwashers and nuts. Mount one way for Cat. II and turn over for Cat. III.

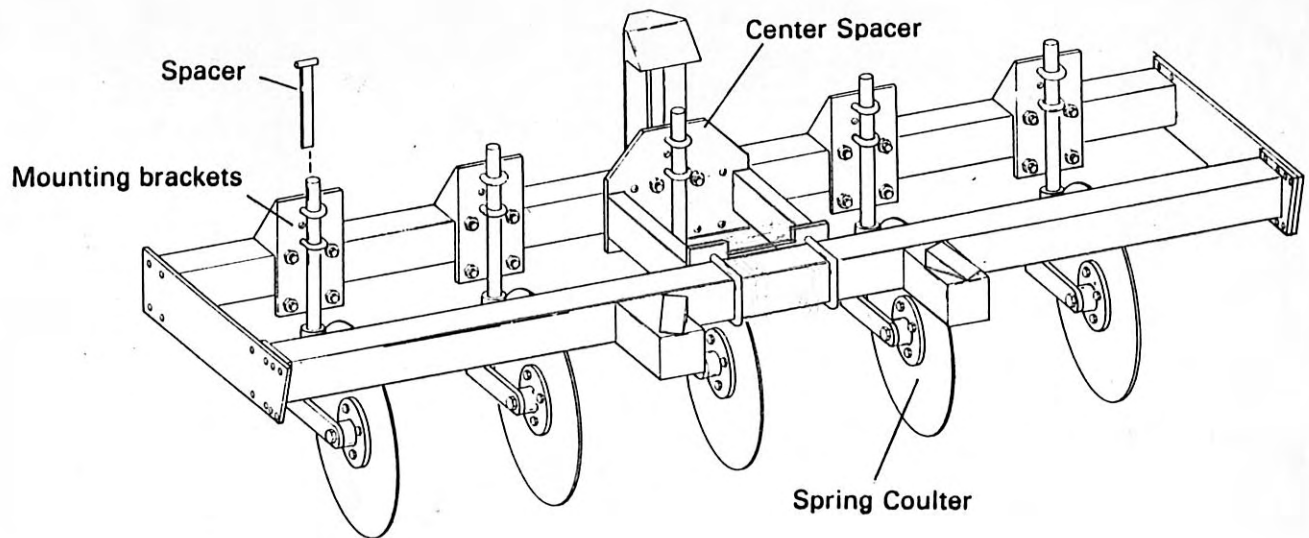

## SPRING COULTER ASSEMBLY

Assemble the center spacer between frame members as shown. Use u-bolts to mount. Before attaching to front frame member, remove the center hitch mast. Reattach the center hitch mast to front frame member using center spacer and bolts.

Attach the center mast braces, left and right, to the center mast and to single beam frame using  $3/4"$  x  $1-1/2"$  bolts to mount. You will have to drive the rear mounting brace down to attach the rear of the mast brace to mounting brace.

Mount the spring couler mounting brackets to rear of front frame member using  $8\ 1/2$  x  $5$  x  $8\ 1/2"$  u-bolts, lock washers and nuts. Space couler mounting brackets out equally across the frame member. Mount a spring couler assembly to the center spacer using u-bolts, spacer, lock washers and nuts. Attach spring coulers to mounting brackets using u-bolts and spacers. Place spacer between bracket and spring couler shaft. Adjust all coulers to desired depth setting by sliding up or down and tightening in position with u-bolts.



## SHANK ASSEMBLY

Refer to the shank spacing chart for correct placement of each shank. The shanks are on 15" or 30" spacings.

Assemble shank mounting bracket using 3/4" x 7" hex bolts. Front plate must be installed between hex bolts and main frame. Tighten set screws.

Attach the shank to the mounting bracket using a 1" x 4" king pin and lock nut. Mount the rear arm to the shank. Place the leaf spring between the arms using 5/8" x 7" carriage bolts and lock nuts.

To adjust the spring pressure turn the adjusting bolt located in the rear leaf spring arm to obtain correct pressure. Camber must be 27" from center of pin to center of pin. Repeat this procedure for each shank mounting.

### IMPORTANT!

Place hydraulic jack on top of the shank and under leaf spring when cambering spring to prevent stripping of adjustment bolt.

Use 5/8" lock nuts. DO NOT TIGHTEN spring holder clevis tightly to spring for spring must move freely.

Assemble the shovel to shank with clipped head plow bolts and nuts. Mount the cover blade assembly to the shank with 5/8" x 3" carriage bolt, lock washer and nut.

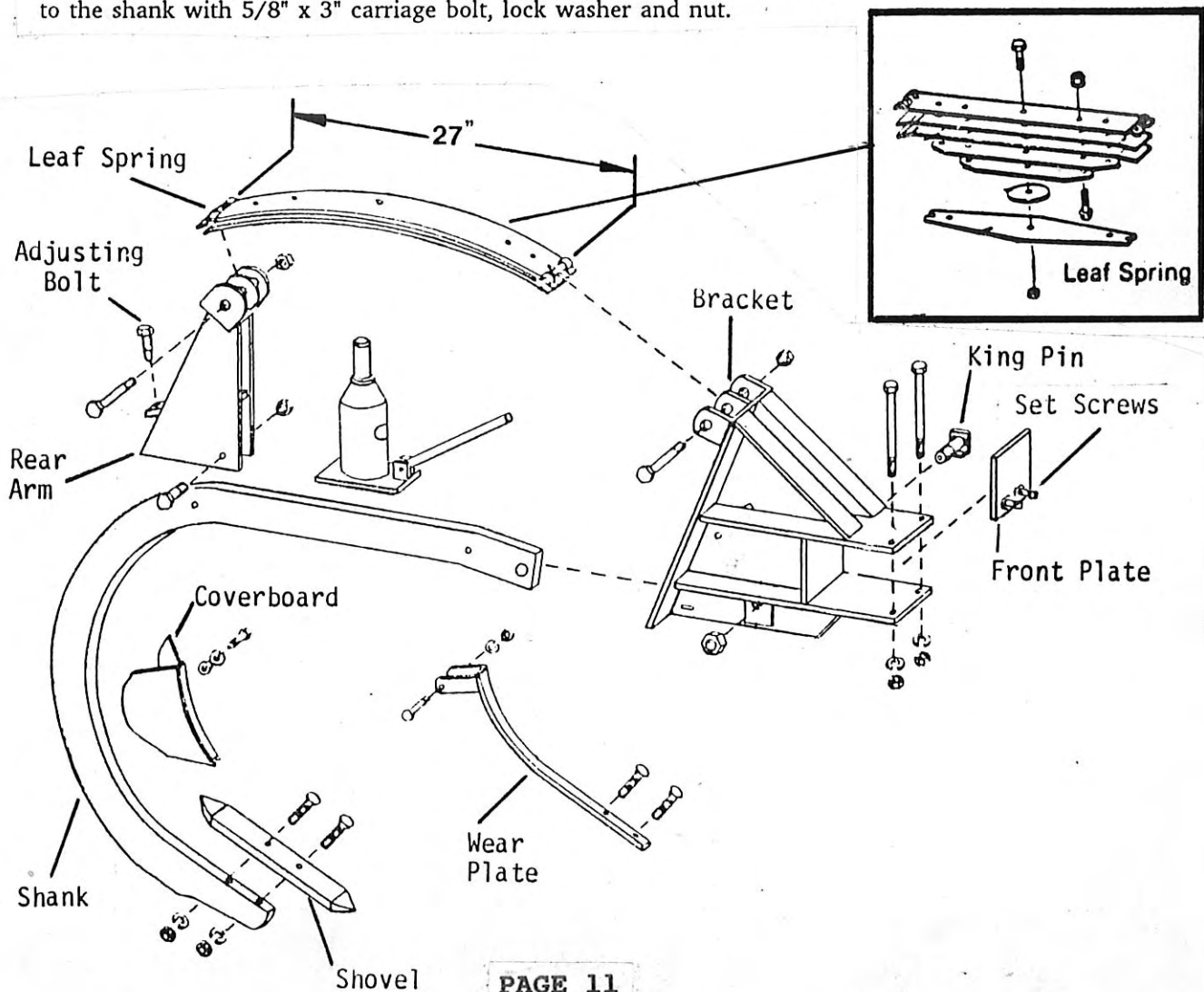

## Ridge Ripper ASSEMBLY

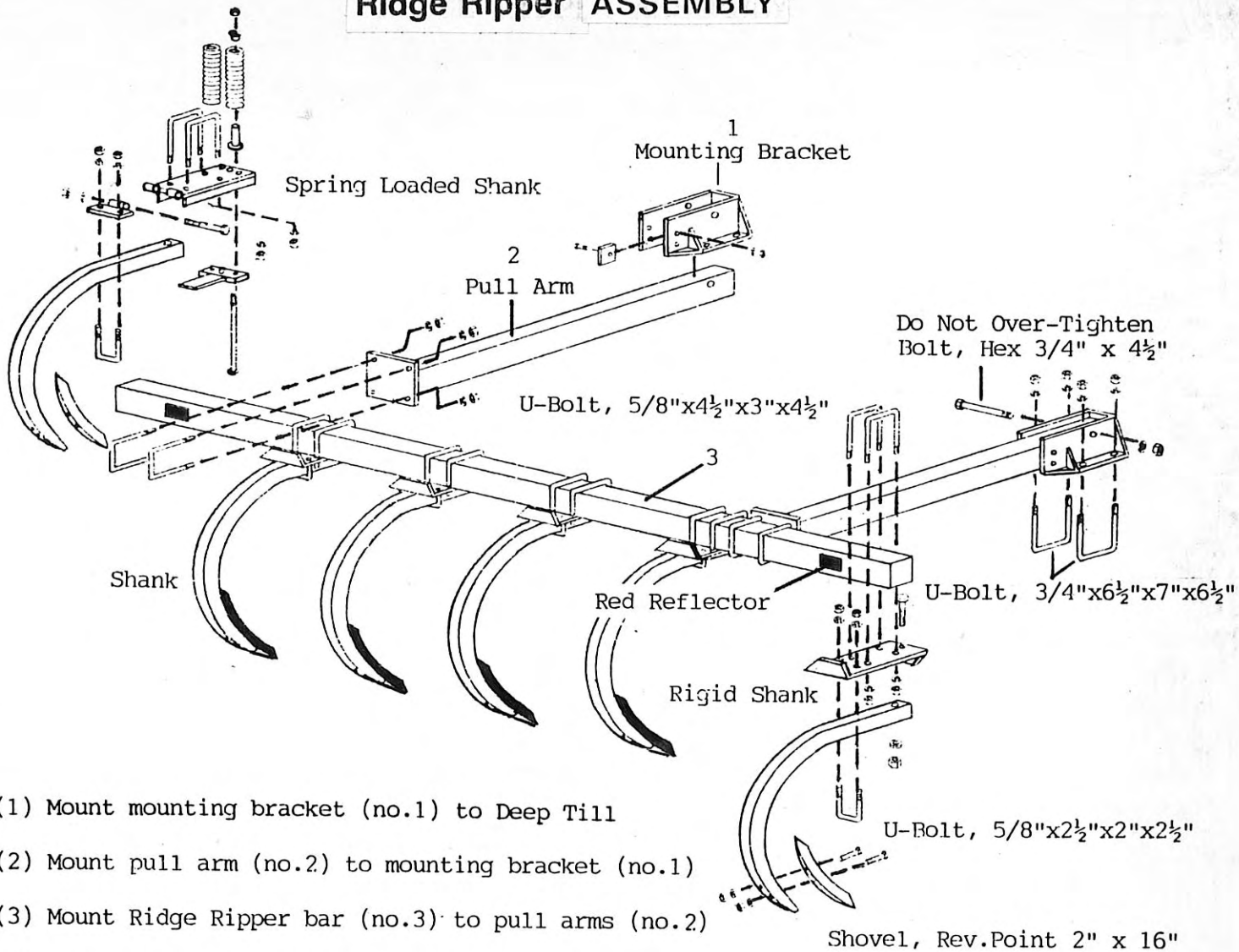

- (1) Mount mounting bracket (no.1) to Deep Till
- (2) Mount pull arm (no.2) to mounting bracket (no.1)
- (3) Mount Ridge Ripper bar (no.3) to pull arms (no.2)
- (4) Mount shank assemblies to bar (no.3)

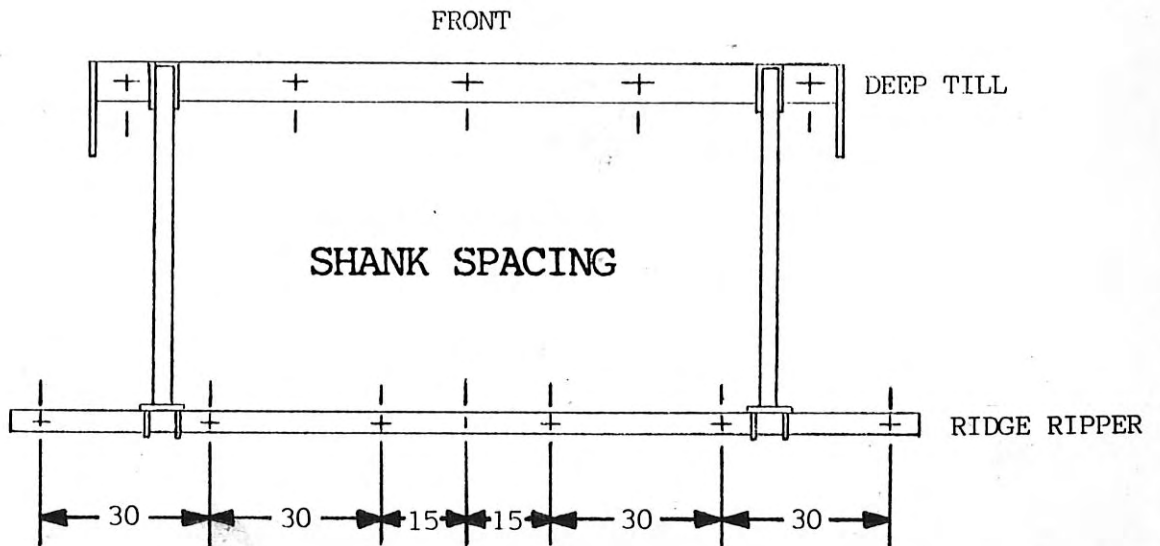

# OPTIONAL EQUIPMENT

## POLE HITCH

Mount the pole to the frame using two 1-7/16" x 10" pins. Connect the arms between the hitch mast and the pole lug. Use a cylinder pin and two hairpin cotters on the pole lug. A 1" x 6" pin and klik pin is used in the hitch mast.

Mount jack to pole with pin. Fold jack up when in storage position and turn down and lock to use in working position.

Adjust the pole to the correct height for tractor drawbar by sliding the arms together. Secure the arms in position with two 5/8" x 3-1/2" bolts, lock washers and nuts. The frame should be level in field position.

The clevis mounts to the pole with a 1-7/16" x 10" clevis pin and 3/8" x 2-1/4" roll pin.

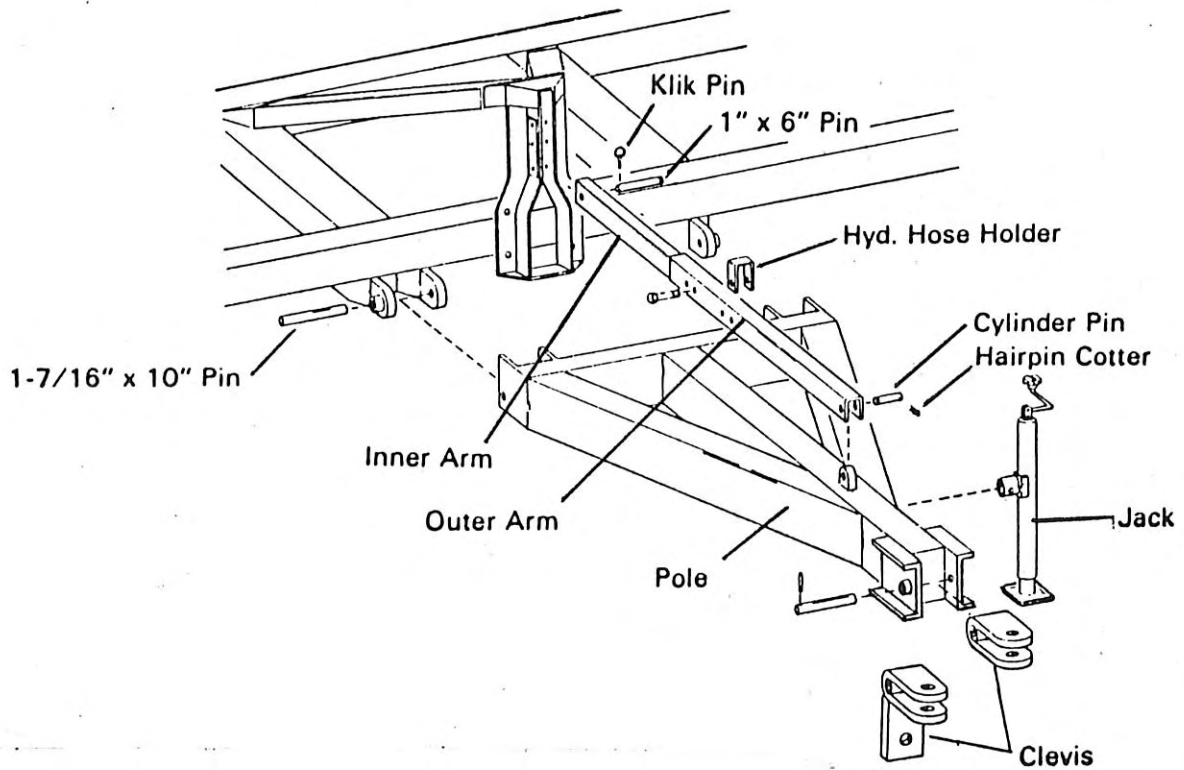



## EXTENSIONS

Extensions are available to increase your basic frame to a size that fits your tractor power. The 11 shank model requires mounting of single extensions to the front frame plate.

There are two types of double extensions. On the 13 shank models only the double drop thru extension is

required. Mount to the frame plates. The 15 and 17 shank models require mounting of both double extensions. Mount the double drop thru extensions to the frame and connect the double extensions to the double drop thru extensions. The 19 shank models require mounting of the single extension to the rear plate of the double extensions.

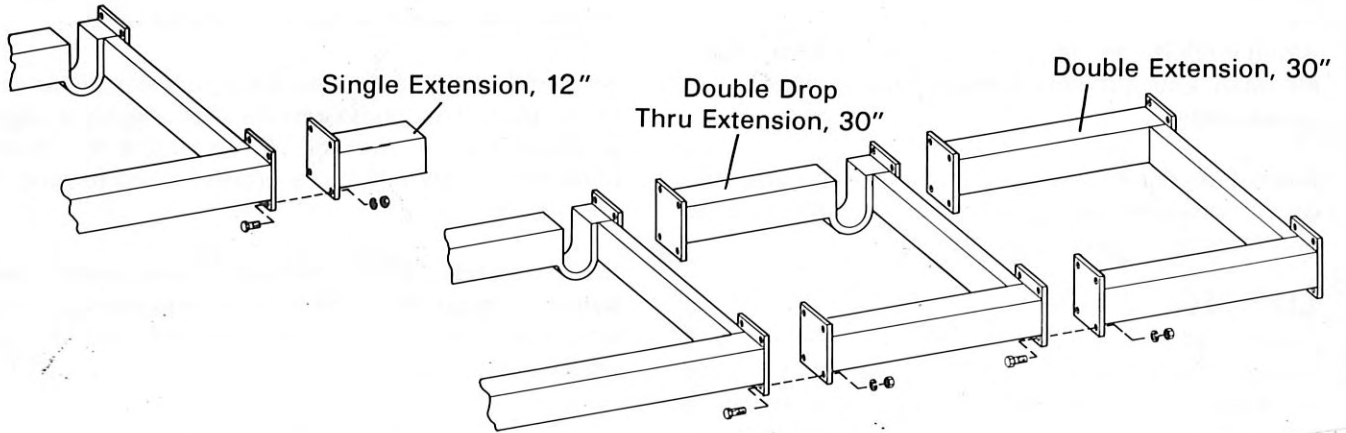

# HYDRAULIC SYSTEM

The chisel plow is equipped with a slave system hydraulic system. Refer to the charts for placement of cylinders and hoses. Mount the cylinders to the axles with cylinder pins and hairpin cotters. Place the cylinder in order of size on the chisel plow. Use the street elbows to connect the hoses to the cylinders. Use a good grade of sealant on all fittings to prevent leaking. The swivel hoses are used between each cylinder. Clamp the hoses to the frame when completed with the tie straps provided.

On pull type models an additional two couplers and 2 - 102" hoses are provided. Tebben does not furnish the quick couplers for the hoses.

**IMPORTANT:** When raising the chisel plow, the cylinder must be extended completely — this activates poppet valve in the cylinder to equalize the unit.

Cylinder #  
Stamped Here

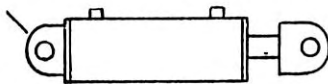

## WARNING

Learn about the series cylinder system before operating because it is different than other hydraulic systems. Purge cylinders well before operating machine by raising and lowering machine, possibly as many as ten (10) times to free system from all air pockets. The oil is fed from large #1 cylinder to small #2 cylinder, etc. There are poppet valves at the top of all cylinders to equalize any difference of oil. Therefore, it is necessary to raise machine all the way out of the ground at each end so as to equalize cylinders again.

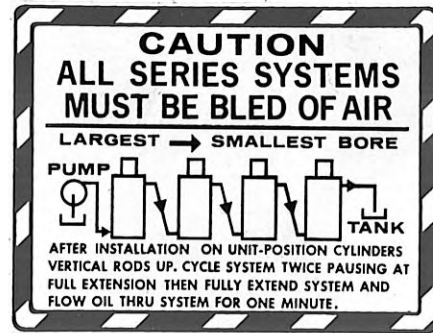

### 13,15 Shank Models (15" Spacing)

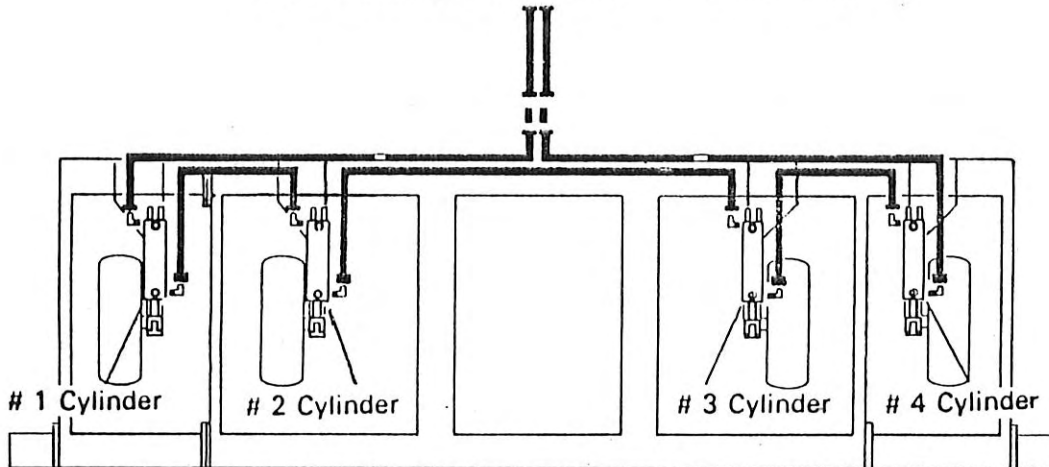

### 17, 19 Shank Models (15" Spacing)

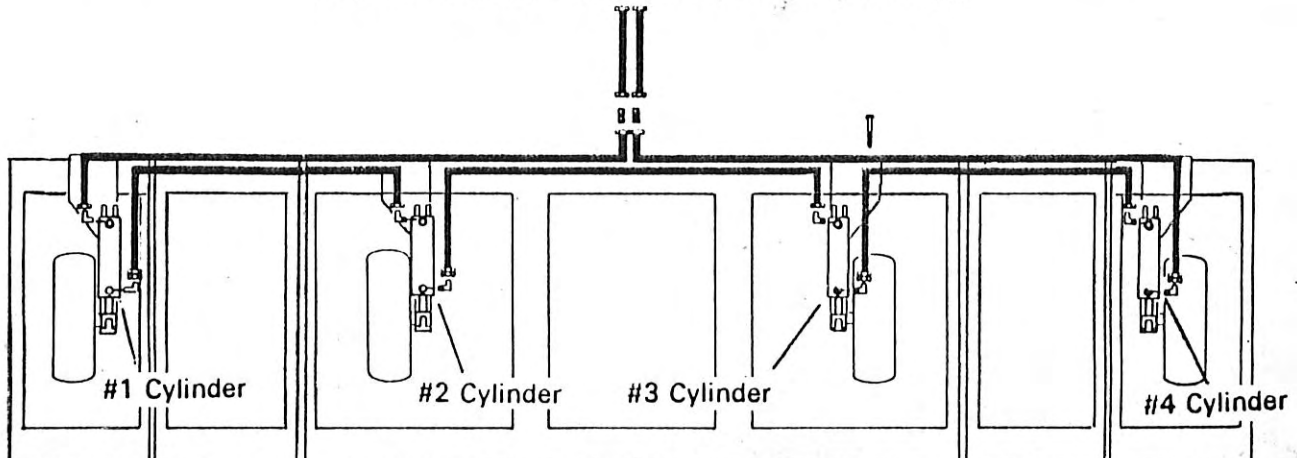

# HYDRAULIC SYSTEM (15", 30" Spacing)

CYLINDER NO.  
STAMPED HERE

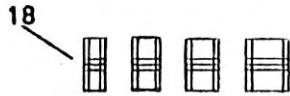
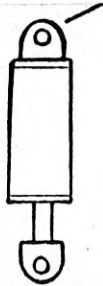

DT5-30, DT7-15,  
DT9-15 & DT11-15  
2 WHEEL MODEL

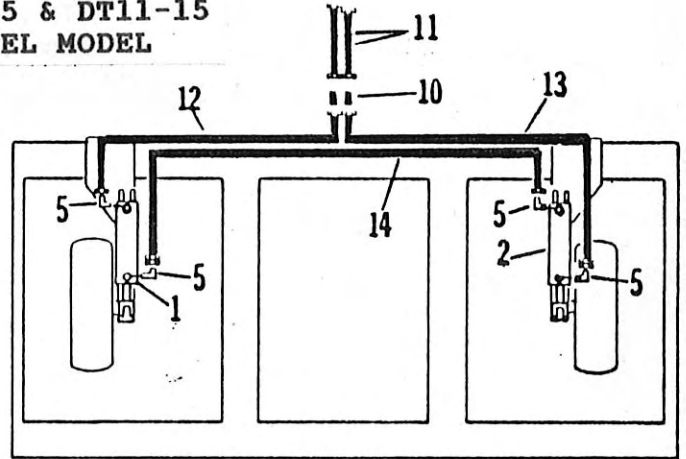

DT7-30, DT13-15,  
DT15-15 4 WHEEL MODEL

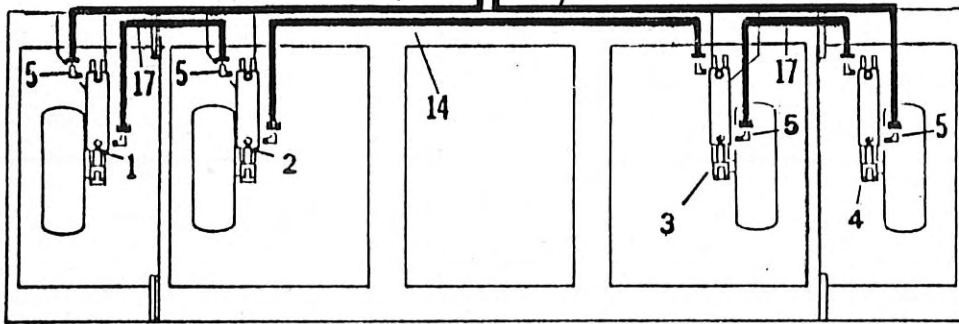
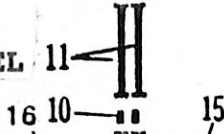

DT9-30, DT11-30  
DT17-15, DT19-15 4 WHEEL MODEL

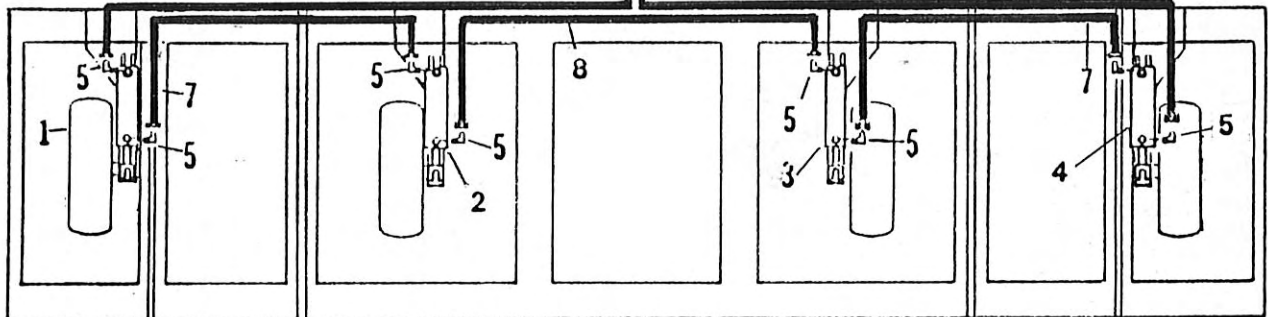
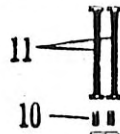



HYDRAULIC SYSTEM (15", 30" SPACING)

REF.	PART NO.	DESCRIPTION	QTY.
1	TM76-00-60	4" CYLINDER #1	1
2	TM76-00-61	3-3/4" CYLINDER #2	1
3	TM76-00-62	3-1/2" CYLINDER #3	1
4	TM76-00-63	3-1/4" CYLINDER #4	1
5	TM76-00-64	STREET ELBOW 3/8"	4
6	TM76-00-65	HOSE, 120"	1
		3/8" TO 3/8" SOLID	
7	TM76-00-66	HOSE, 95"	2
		3/8" TO 3/8" SOLID	
8	TM76-00-67	HOSE, 180"	1
		3/8" SWIVEL TO 3/8" SOLID	1
9	TM76-00-68	HOSE, 134"	
		3/8" SWIVEL TO 1/2" SOLID	
10	TM76-00-69	1/2" COUPLING (PULL-TYPE HITCH)	2
11	TM76-00-70	HOSE, 116" 1/2" MALE TO 1/2" FEMALE (PULL-TYPE HITCH)	2
12	TM76-00-71	HOSE, 70" 3/8" TO 1/2" SOLID	1
13	TM76-00-72	HOSE, 84" SWIVEL TO 1/2" SOLID	2
14	TM76-00-73	HOSE, 120"	1
		3/8" SWIVEL TO 3/8" SOLID	
15	TM76-00-74	HOSE, 114"	2
		3/8" SWIVEL TO 1/2" SOLID	
16	TM76-00-75	HOSE, 100"	1
		3/8" SWIVEL TO 1/2" SOLID	
17	TM76-00-198	HOSE 65" 3/8" SWIVEL TO 3/8" SOLID	3
18	TM76-00-187	ONE SET OF DEPTH STOPS	4

# 15" SHANK SPACING CHART

## 7, 9, 11 Shank Models

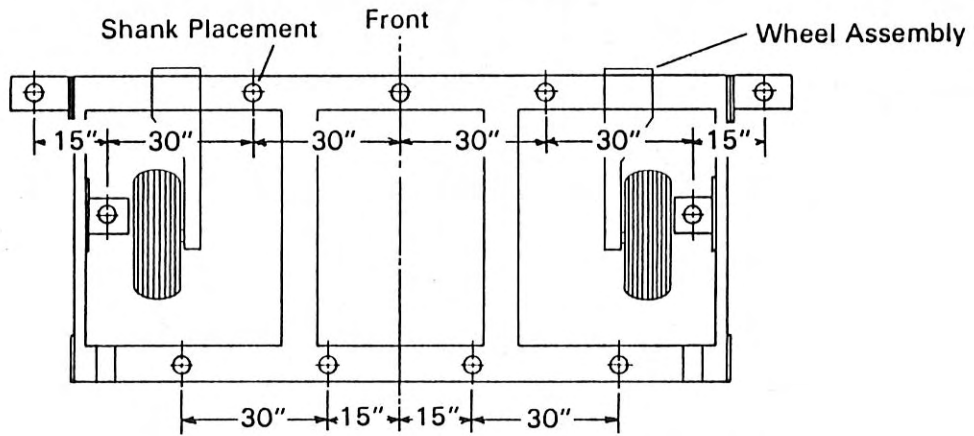

## 13, 15 Shank Models

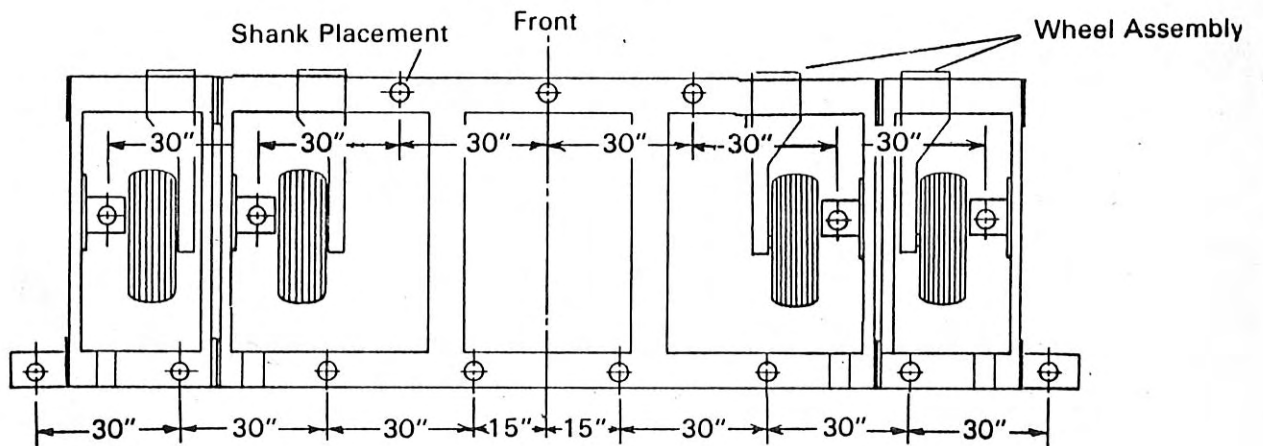

## 17, 19 Shank Models

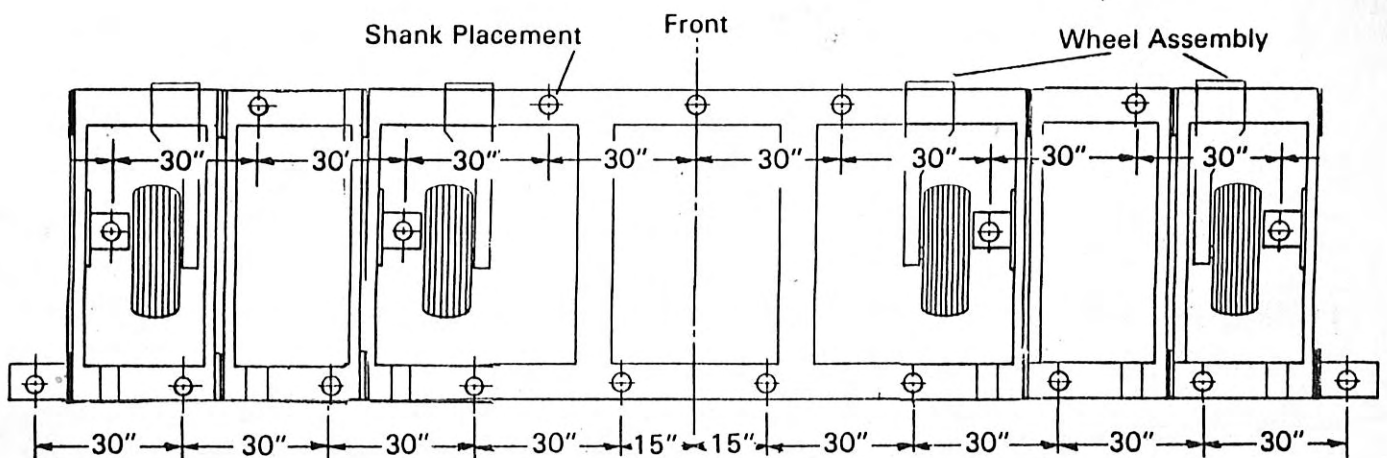

### 7, 9, 11 Shank Models (15" Spacing)

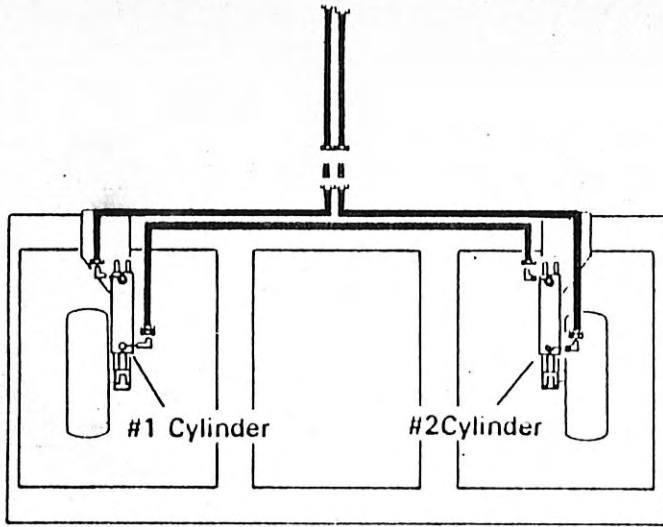

### 5 Shank Model (30" Spacing)

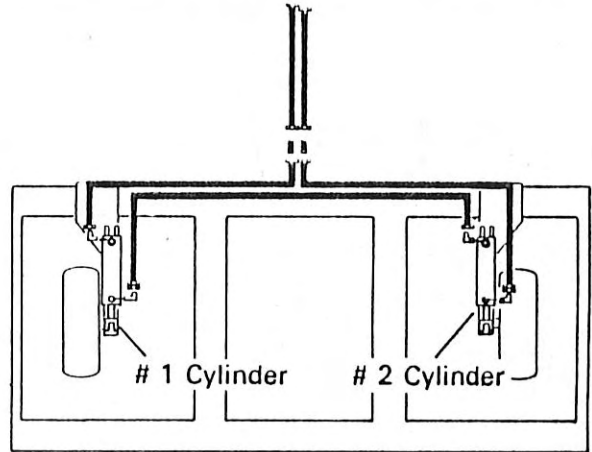

### 9, 11 Shank Models (30" Spacing)

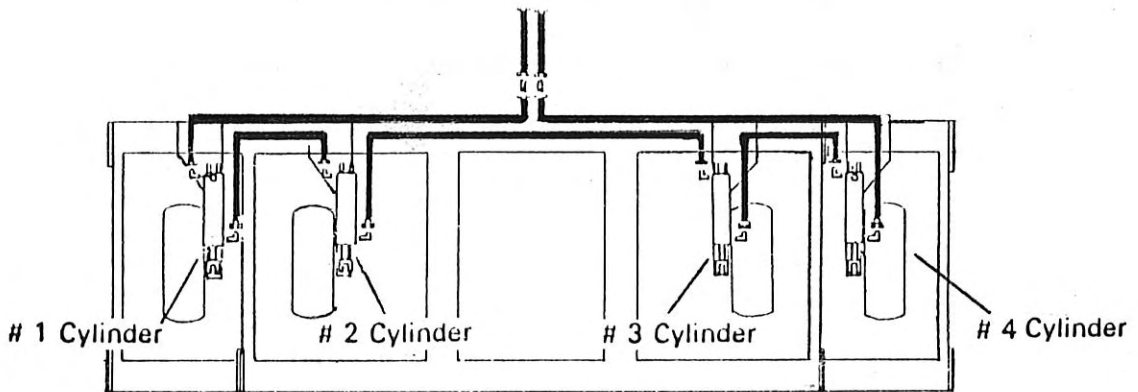

### 9, 11 Shank Models (30" Spacing)

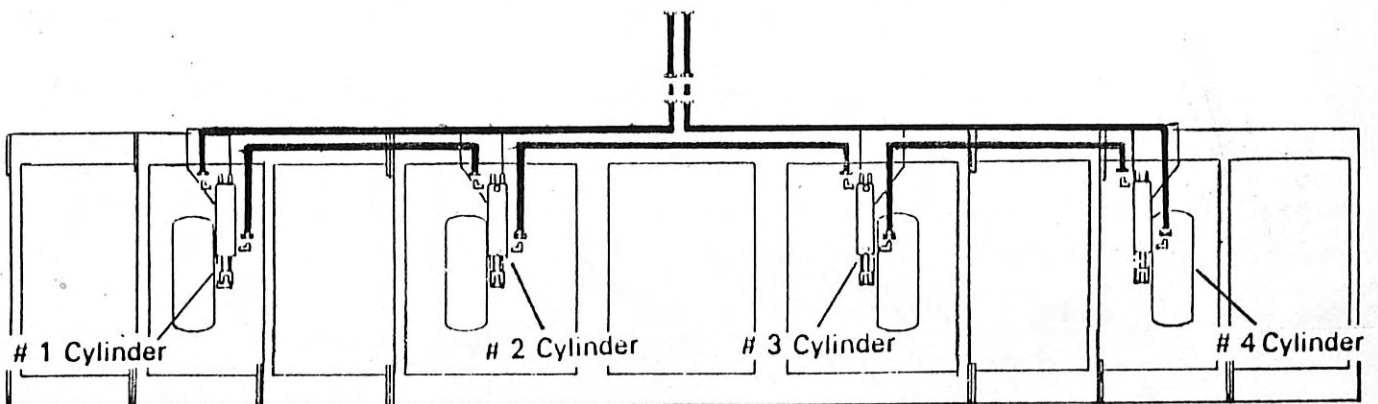



# 30" SHANK SPACING CHART

## 5 Shank Model

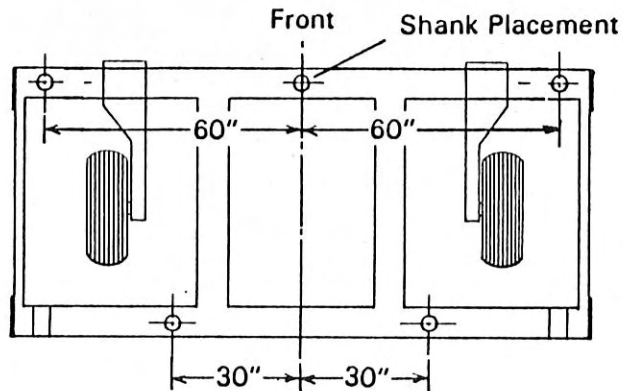

## 7 Shank Model

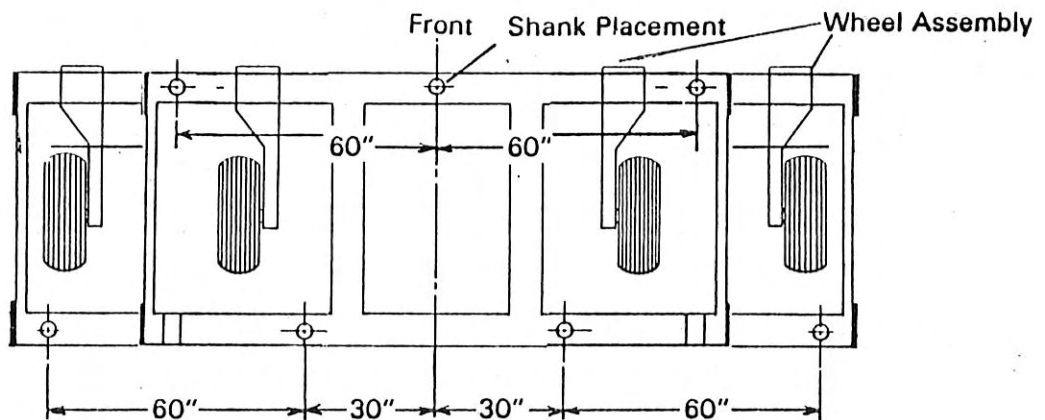

## 9, 11 Shank Models

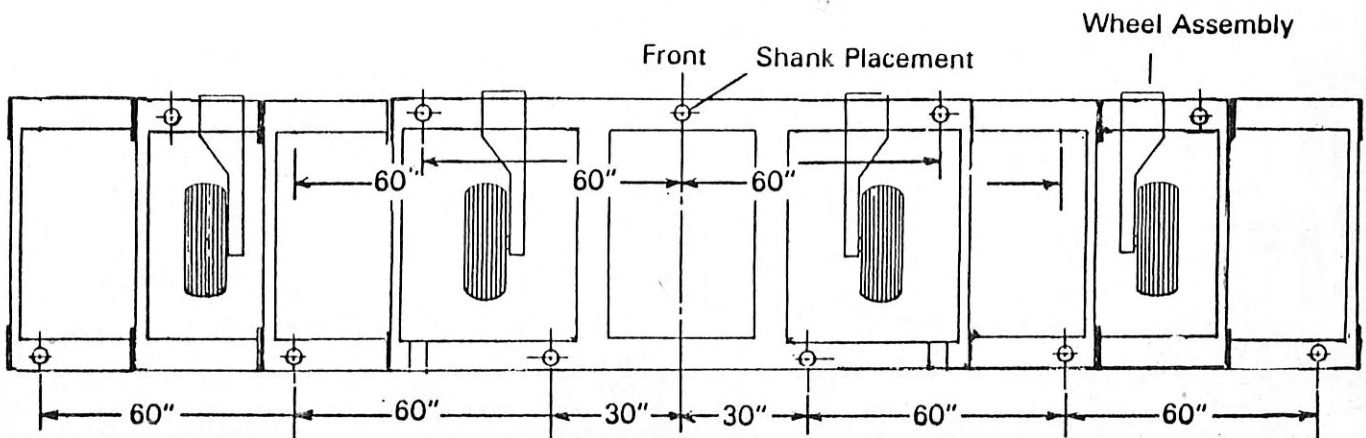

# SINGLE BEAM SHANK SPACINGS

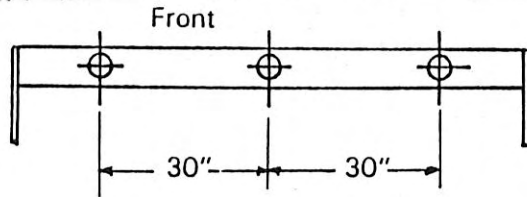

**3 SHANK MODELS**

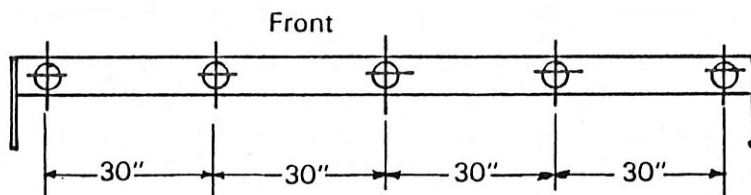

**5 SHANK MODELS**

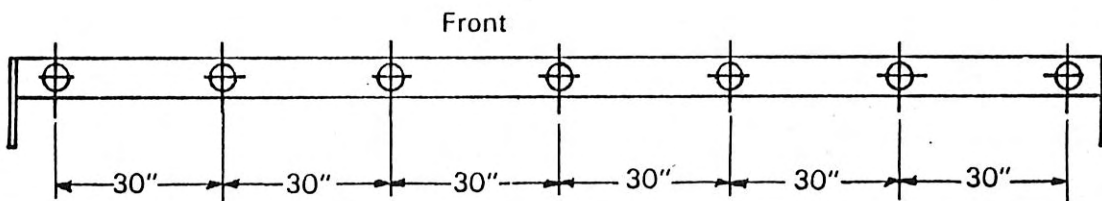

**7 SHANK MODELS**

DECAL LISTING

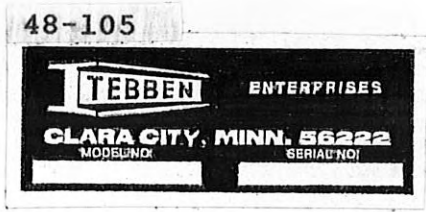

TM76-23

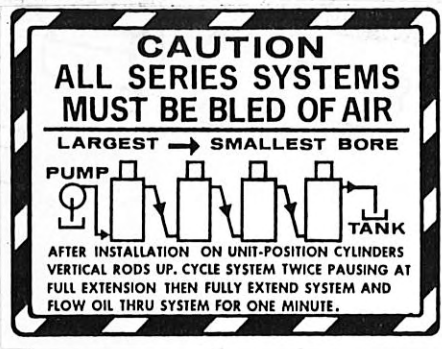

TM76-21

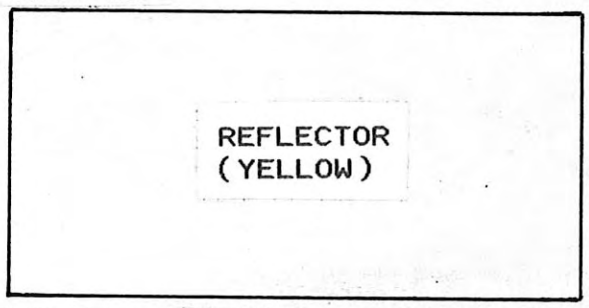

2109-501



48-104



TM76-15

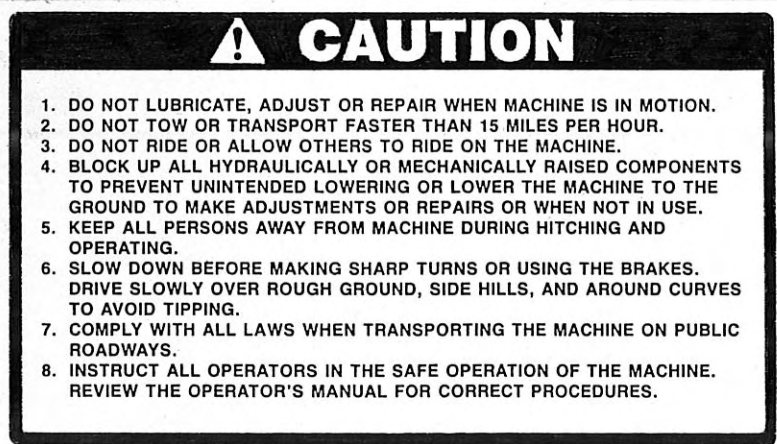

TM76-22

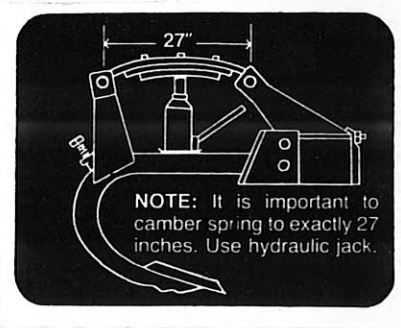

TM76-12



TM76-20

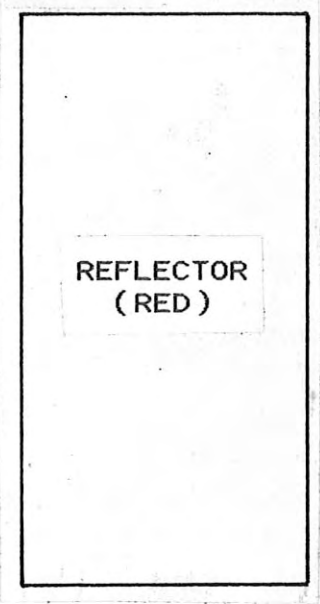

# MAIN FRAME ASSEMBLY

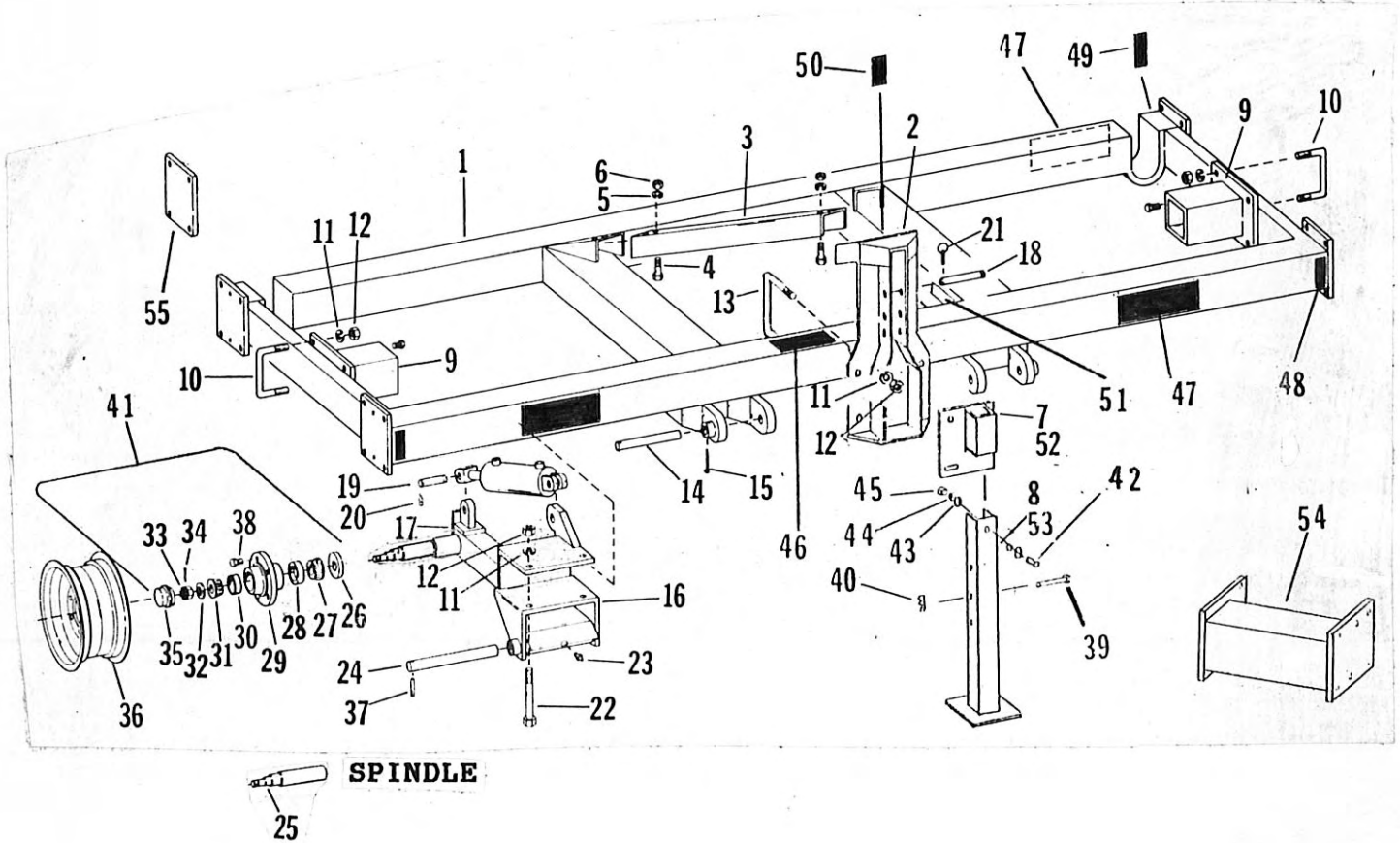



MAIN FRAME ASSEMBLY

REF.	PART NO.	DESCRIPTION	QTY.
1	TM76-00-01	MAIN FRAME WITH DROP U'S	1
	TM76-00-200	MAIN FRAME LESS DROP U'S	1
2	TM76-246	CENTER MAST	1
3	TM76-00-03	BRACE, MAST	2
4	TM76-00-04	BOLT, 3/4" X 1 1/2"	8
5	TM76-00-11	WASHER, LOCK 3/4"	8
6	TM76-00-12	NUT, HEX, 3/4"	8
7	TM76-00-194	STAND BRACKET/SQUARE TUBE	1
8	TM76-00-195	PARKING STAND/SQUARE TUBE	1
9	TM76-00-09	EXTENSION SETBACK 7"	2
10	TM76-00-10	U-BOLT 3/4" X 4" X 5" X 4"	4
11	TM76-00-11	WASHER, LOCK 3/4"	12
12	TM76-00-12	NUT, HEX, 3/4"	14
13	TZ75-00-24	3/4"X8 1/2"X5X8 1/2" U-BOLT	2
14	TM76-00-14	PIN, 1-7/16" DIA X 10"	2
15	TM76-00-15	COTTER KEY 5/16" X 3-1/4"	2
16	TM76-00-16R	BRACKET, AXEL MTG (RH) SHOWN	1
	TM76-00-16L	BRACKET, AXLE MTG (LH)	1
17	TM76-00-17R	AXLE HOUSING (RH) SHOWN	1
	TM76-00-17L	AXLE HOUSING (LH)	1
18	TM76-00-55	PIN, UPPER 3 PT.	
19	TM76-00-125	PIN, CYLINDER	2
20	TM76-00-126	HAIRPIN COTTER	4
21	TM76-00-59	KLIK PIN	1
22	TM76-00-18	BOLT, HEX, 3/4" X 7	2
23	TM76-00-19	GREASE FITTING POUND IN	1
24	TM76-00-20	PIN 1-7/16" DIA. X 12-1/2"	2
25	TM76-00-21	SPINDLE	1
26	TM76-00-22	SEAL	1
27	TM76-00-23	CONE, INNER	1
28	TM76-00-24	CUP, INNER	1
29	TM76-00-25	HUB, (W/CUPS) 6 BOLT	1
30	TM76-00-26	CUP, OUTER	1
31	TM76-00-27	CONE, OUTER	1
32	TM76-00-28	WASHER	1
33	TM76-00-29	NUT, SLOTTED	1
34	TM76-00-30	COTTER PIN	1
35	TM76-00-31	CAP, HUB	1
36	TM76-00-32	RIM, 15" X 8" (6 BOLT)	1
37	TM76-00-56	ROLL PIN, 3/8" X 2-1/4"	2
38	TM76-00-92	WHEEL BOLT	5
39	TM76-00-191	PICKER PIN, 1/2 X 3-1/2	1
40	709	HAIRPIN	1
41	TM76-285	HUB ASSY COMPLETE W/BOLT	1
42	910	HEX BOLT 3/8" X 1"	1
43	424	FLAT WASHER 3/8"	2
44	912	LOCK WASHER 3/8"	1
45	425	HEX NUT 3/8"	1
46	TM76-12	CAUTION DECAL	1
47	TM76-21	TEBBEN DECAL 4 1/2" X 9"	4
48	TM76-20	REFLECTOR YELLOW	2
49	TM76-20	REFLECTOR RED	2
50	48-104	FEMA DECAL	1
51	48-105	SERIAL NO.	1
52	TM76-300	STAND BRACKET 1994 CHANNEL	1
53	TM76-281	PARKING STAND SHOWN CHANNEL	1
54	TM76-310	STUB EXTENTION 12"	2
55	TM76-305	END PLATE ONLY	1

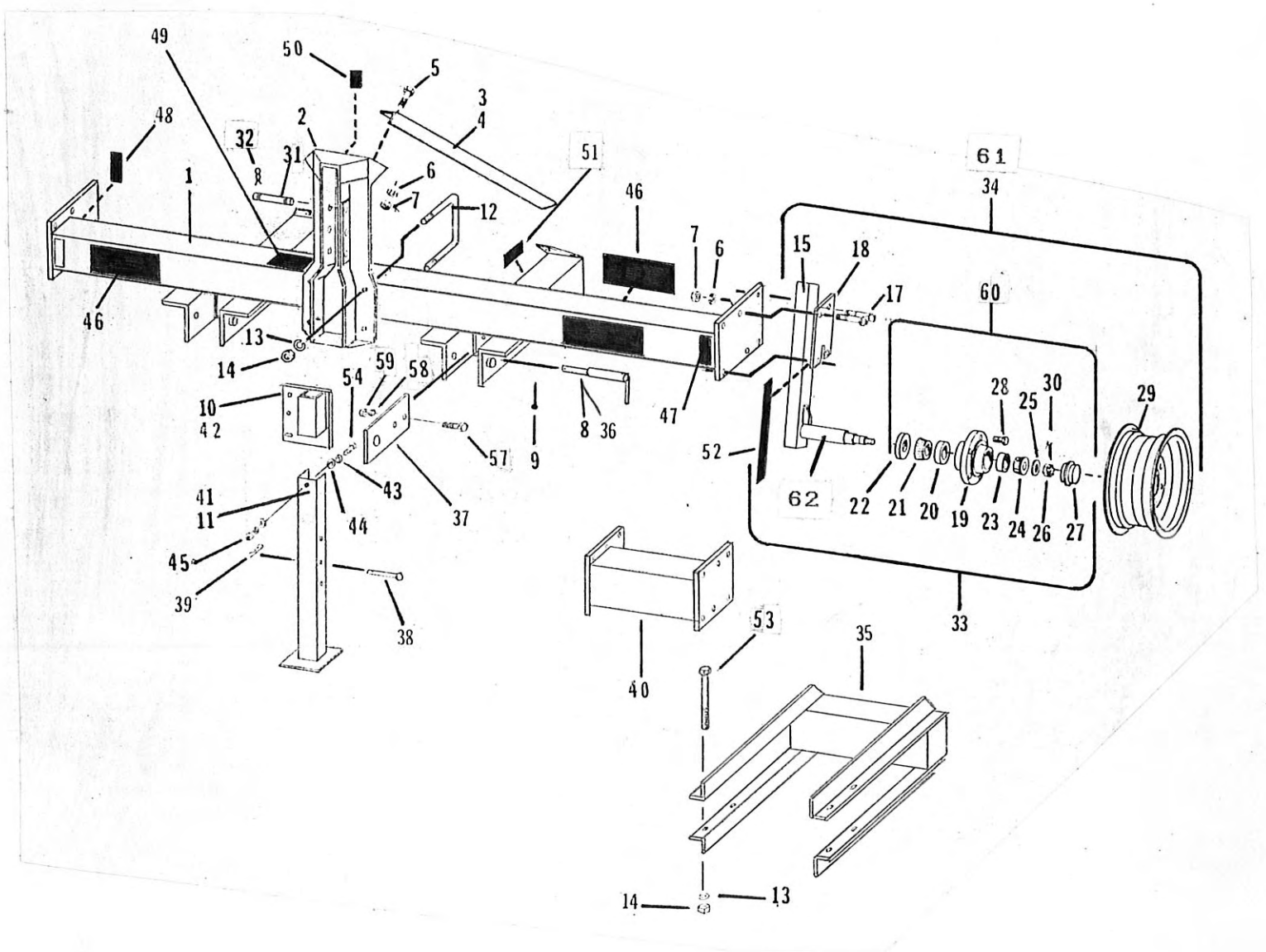

SINGLE FRAME ASSY.

REF.	PART NO.	DESCRIPTION	QTY.
1	TM76-00-128	FRAME, 3 SHANK	1
	TM76-00-129	FRAME, 5 SHANK	1
	TM76-00-146	FRAME, 7 SHANK	1
2	TM76-245	CENTER MAST	1
3	TM76-00-131	BRACE, CENTER MAST, R	1
4	TM76-00-132	BRACE, CENTER MAST, L	1
5	TM76-00-04	BOLT, 3/4" X 1-1/2	8
6	TM76-00-11	WASHER, LOCK, 3/4"	16
7	TM76-00-12	NUT, HEX, 3/4"	16
8	TM76-00-153	PIN, 1-7/16" X 9" CAT. 3	2
	TM76-00-143	PIN, 1-1/8" X 9", CAT. 2	2
9	TM76-00-15	COT. KEY, 5/16" X 3-1/4"	2
10	TM76-00-194	STAND BRACKET SQUARE TUBE	1
11	TM76-00-195	PARKING STAND SQUARE TUBE	1
12	TZ75-00-24	U-BOLT 3/4 X 8-1/2 X 5 X 8-1/2	2
13	TM76-00-11	WASHER, LOCK 3/4"	4
14	TM76-00-12	NUT, HEX 3/4"	4
15	TM76-00-134	ARM, GAUGE WHEEL WITH SPINDLE	2
17	TM76-00-192	BOLT 3/4" X 4"	8
18	TM76-00-193	PLATE, MOUNTING	2
19	TZ75-00-97	HUB W/CUPS	1
20	TZ75-00-96	CUP, INNER	1
21	TZ75-00-95	CONE, INNER	1
22	TZ75-00-94	SEAL	1
23	TZ75-00-98	CUP, OUTER	1
24	TZ75-00-99	CONE, OUTER	1
25	TZ75-00-103	WASHER, FLAT	1
26	TZ75-00-102	NUT, SLOTTED	1
27	TZ75-00-101	CAP, HUB	1
28	TM76-00-92	WHEEL BOLT	5
29	TM76-00-196	RIM, 15" X 4-1/2" TIRE SIZE: 6:70 X 15	2
30	TZ75-00-100	COTTER PIN 5/16" X 3-1/4"	1
31	TM76-00-55	PIN, UPPER 3 PT.	1
32	TZ75-00-46	HAIRPIN COTTER	2
33	TM76-00-156	GAUGE WHEEL ARM W/HUB	1
34	TM76-00-162	GAUGE WHEEL ASSEMBLY 5 BOLT COMPLETE (1 ONLY)	2
35	TM76-00-157	SET-BACK EXTENSION	2
36	TM76-00-169	CAT. II & III HITCH PIN	2
37	TM76-00-174	PLATE	2
38	TM76-00-191	PIN 1/2" X 3 1/2" PICKER	1
39	709	HAIRPIN	1
40	TM76-00-189	30" STUB EXT.	2
41	TM76-281	PARKING STAND SHOWN (CHANNEL)	1
42	TM76-300	STAND BRACKET SHOWN (CHANNEL)	1
43	424	FLAT WASHER 3/8"	2
44	912	LOCK WASHER 3/8"	2
45	425	HEX NUT 3/8"	1
46	TM76-12	TEBBEN, DECAL 4 1/2" X 9"	4
47	TM76-21	REFLECTOR YELLOW	2
48	TM76-20	REFLECTOR RED	2
49	TM76-15	CAUTION DECAL	1
50	48-104	FEMA DECAL	1
51	48-105	SERIAL NO.	1
52	2109-501	GAUGE WHEEL DECAL	2
53	TM76-00-18	HEX BOLT 3/4" X 7"	2
54	910	HEX BOLT 3/8" X 1"	1
55	TM76-280	WHEEL SET BACK PLATE	2
56	TM76-305	END PLATE	1
57	TM76-00-137	BOLT 5/8" X 1 1/2" HEX	4
58	TM76-00-5	LOCK WASHER 5/8"	4
59	TM76-00-6	NUT HEX 5/8"	4
60	TM76-286	5 BOLT HUB ASSEMBLY	1
61	TM76-00-262	GUAGE WHEEL ASSY COMPLETE 6 BOLT HUB, SPINDLE, RIM (15 X 6 X 8) 1 ONLY 2 PER MACHINE	2
62	TM76-287	SPINDLE ONLY FOR 5 BOLT HUB	1

# TRASH CUTTER FRAME GROUP

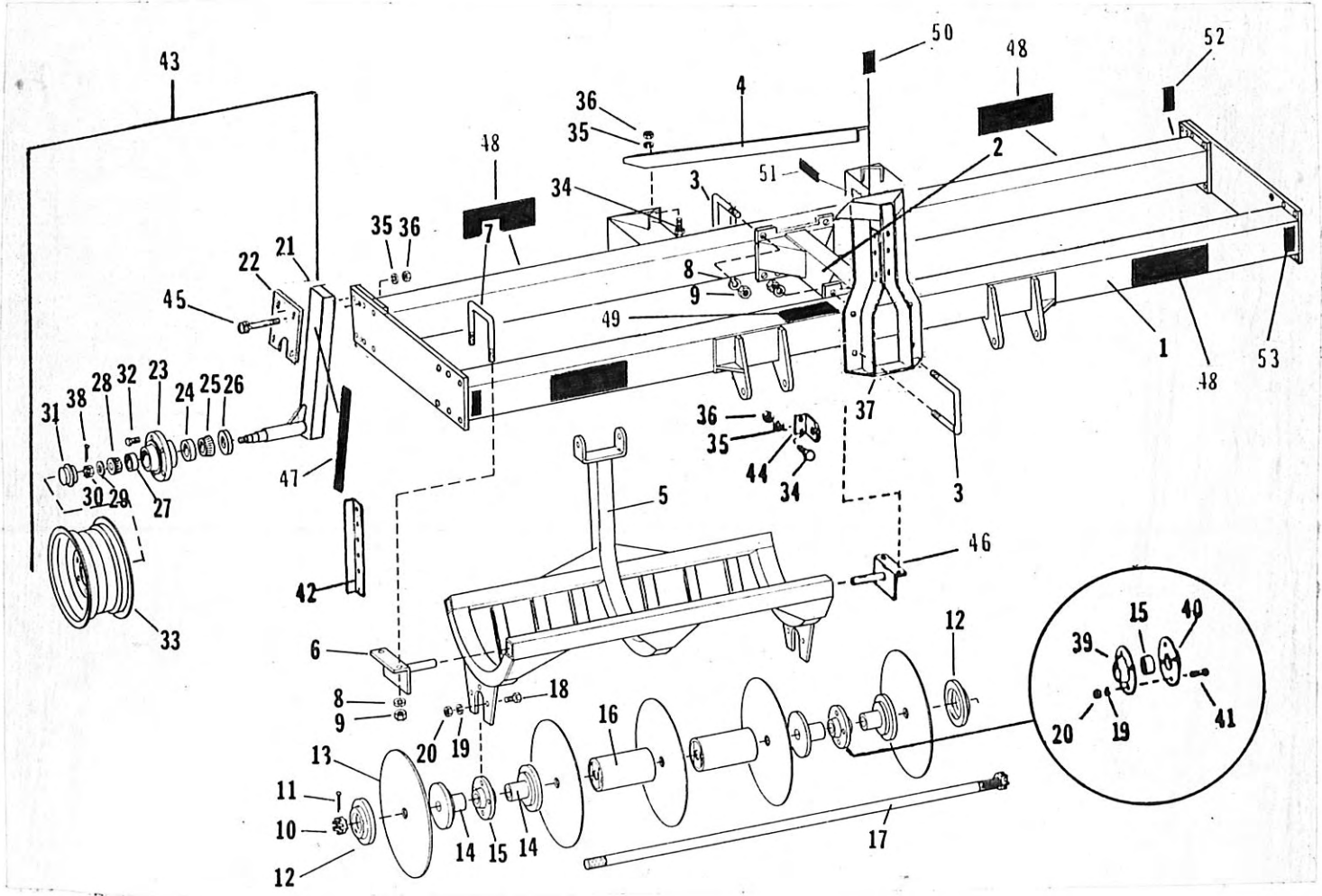



TRASH CUTTER FRAME GROUP

REF.	PART NO.	DESCRIPTION	QTY.
1	TC81-00-501	FRAME, FRONT	1
2	TC81-00-549	CENTER FRAME MOUNT (90 & NEWER)	1
	TC81-00-547	CENTER FRAME MOUNT (84 & NEWER)	1
3	TZ75-00-24	U-BOLT, 3/4" X 8-1/2" X 5" X 8-1/2"	6
4	TC81-00-533	DOUBLE RANK BRACE - 81" (RH.)	1
	TC81-00-503-SR	SINGLE RANK BRACE (RH.)	1
	TC81-00-534	DOUBLE RANK BRACE - 81" (LH.)	1
	TC81-00-504-SR	SINGLE RANK BRACE (LH.)	1
5	TC81-00-505	DISC FRAME, 60"	2
	TC81-00-506	DISC FRAME, 30"	2
6	TC81-00-507-LH	BRACKET, MOUNTING LH.	2
7	TZ75-00-23	U-BOLT, 3/4" X 6-1/2" X 7" X 6-1/2"	4
8	TM76-00-11	WASHER, LOCK, 3/4"	20
9	TM76-00-12	NUT, HEX, 3/4"	20
10	TC81-00-508	NUT, SLOTTED 1-1/2"	1
11	TM76-00-15	COTTER PIN 5/16" X 3-1/4"	1
12	TC81-00-509	END HUB	2
13	TC81-00-510	DISC 20"	8, 4
14	TC81-00-511	SPOOL, HALF	4
15	TC81-00-512	BEARING	2
16	TC81-00-513	SPOOL	5, 1
17	TC81-00-514	SHAFT, 1-1/2" X 64" (5 SHANK)	1
	TC81-00-515	SHAFT, 1-1/2" X 29" (3 SHANK)	1
18	CT84-82	BOLT, HEX, 1/2" X 1-1/2"	6
19	TM76-00-151	WASHER, LOCK, 1/2"	6
20	TM76-00-152	NUT, HEX, 1/2"	6
21	TM76-00-134	ARM, GAUGE WHEEL	2
22	TM76-00-193	PLATE, MOUNTING	2
23	TZ75-00-97	HUB W/CUPS	2
24	TZ75-00-96	CUP, INNER	2
25	TZ75-00-95	CONE, INNER	2
26	TZ75-00-94	SEAL	1
27	TZ75-00-98	CUP, OUTER	1
28	TZ75-00-99	CONE, OUTER	1
29	TZ75-00-103	WASHER, FLAT	1
30	TZ75-00-102	NUT, SLOTTED	1
31	TZ75-00-101	CAP, HUB	1
32	TM76-00-92	BOLT, WHEEL	5
33	TM76-00-196	RIM, 15" X 4-1/2"	2
34	TM76-00-137	BOLT, HEX, 5/8" X 1-1/2"	4
35	TM76-00-05	WASHER, LOCK, 5/8"	4
36	TM76-00-06	NUT, HEX, 5/8"	4
37	TM76-246	CENTER MAST	1
38	TZ75-00-100	COTTER PIN	1
39	TC81-00-530	FANGETTE WITH ZERK	2
40	TC81-00-531	FLANGETTE	2
41	TC81-00-532	CARRIAGE BOLT, 1/2" X 1-1/2"	8
42	TC81-00-536	SCRAPER, 30" - 60" DISKS	2
43	TM76-00-162	GAUGE WHEEL ASSY. COMPLETE	1
44	TC81-00-516	PLATE, CAT. I & II	2
45	TM76-00-192	BOLT, 3/4" X 4"	8
46	TC81-00-507-RH	BRACKET MOUNTING RH	2
47	2109-501	GAUGE WHEEL DECAL	2
48	TM76-12	TEBBEN DECAL 4 1/2" X 9"	4
49	TM76-15	CAUTION DECAL	1
50	48-104	FEMA DECAL	1
51	48-105	SERIAL NO.	1
52	TM76-20	REFLECTOR RED	2
53	TM76-21	REFLECTOR YELLOW	2

# DISK SPRING ASSEMBLY

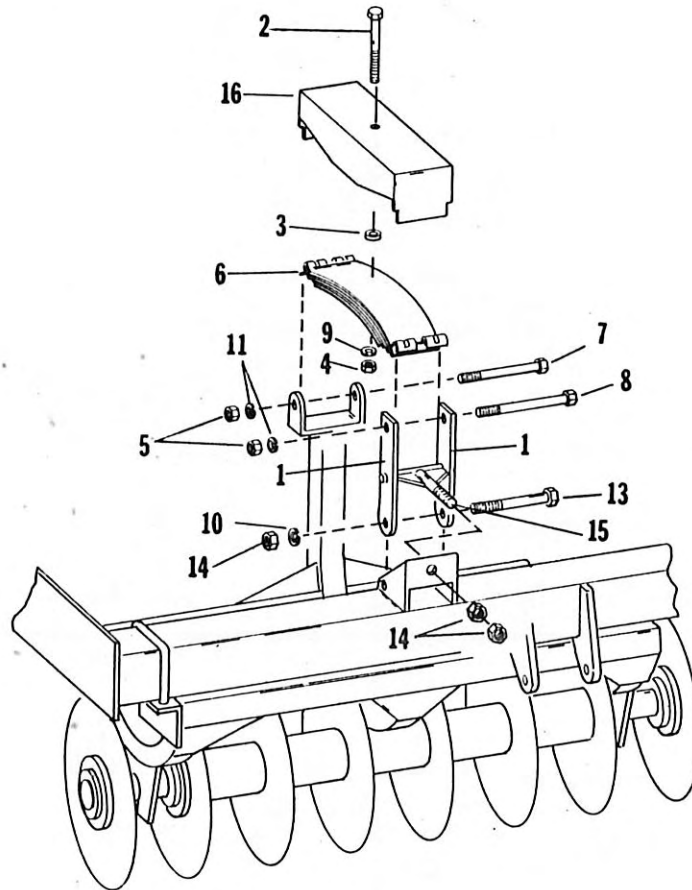

REF.	PART NO.	DESCRIPTION	QTY.
1	TC81-00-517	PLATE	2
2	TC81-00-527	BOLT, 7/16" X 6-1/2" LONG THREAD	1
3	TC81-00-528	BUSHING	1
4	TM76-00-148	NUT, HEX 7/16"	1
5	TM76-00-06	NUT, HEX 5/8"	4
6	TM76-00-38	SPRING ASSEMBLY	1
7	TC81-00-522	BOLT, HEX 5/8" X 8-1/2"	1
8	TC81-00-523	BOLT, HEX 5/8" X 9-1/2"	1
9	TZ75-00-256	WASHER, LOCK 7/16"	1
10	TM76-00-11	WASHER, LOCK 3/4"	1
11	TM76-00-05	WASHER, LOCK 5/8"	4
13	TC81-00-526	BOLT, HEX 3/4" X 8"	1
14	TM76-00-12	NUT, HEX 3/4"	4
15	TC81-00-520	ADJUSTING PIN ASSY.	1
16	TC81-00-529	HOUSING, SPRING ADJ	1

# SPRING COULTER PARTS

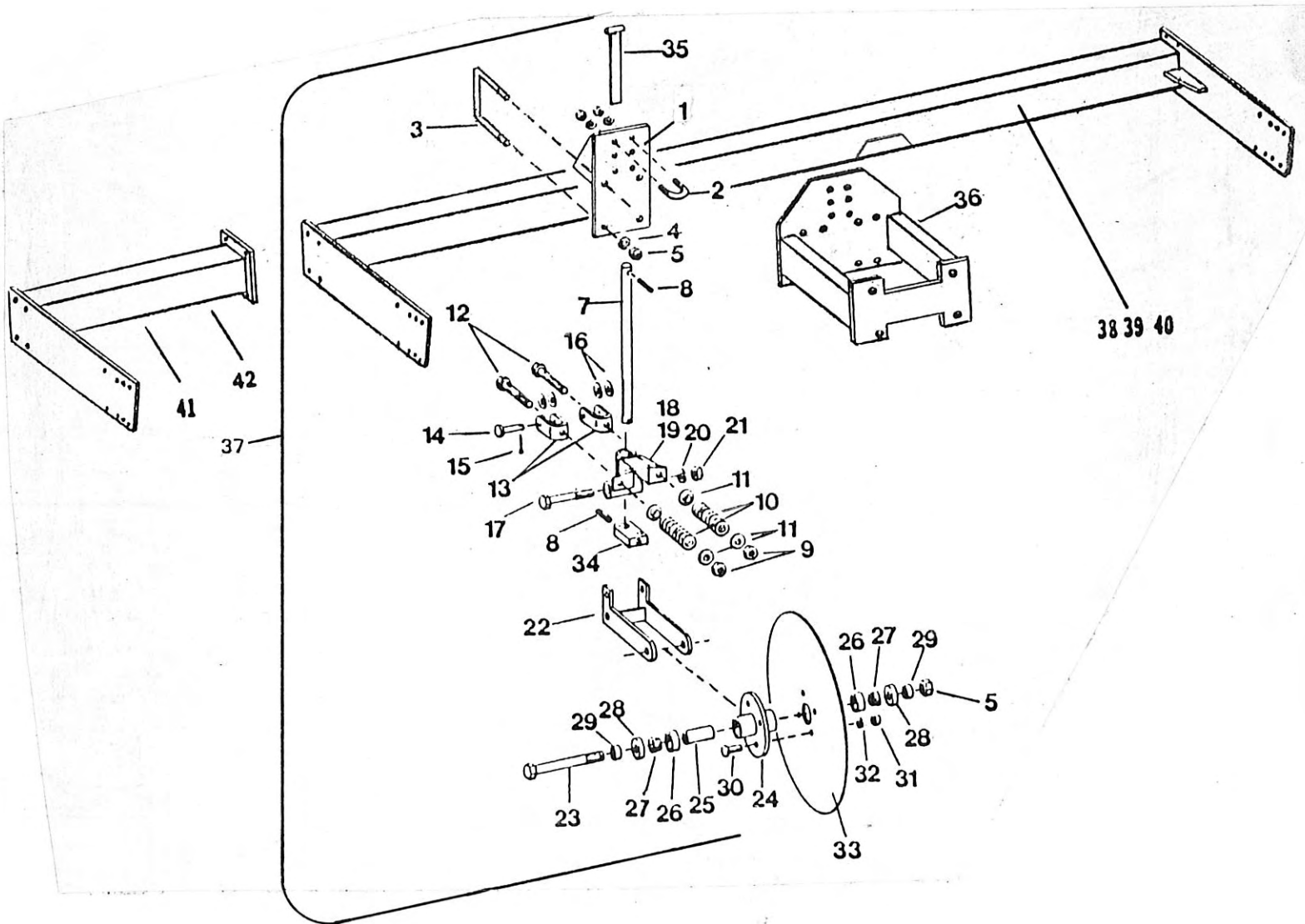

SPRING COULTER PARTS

REF.	PART NO.	DESCRIPTION	QTY.
1	TC81-00-537	MOUNTING BRACKET	1
2	CT84-13	U-BOLT 5/8"	2
3	TZ75-00-24	U-BOLT 3/4" X 8-1/2" X 5" X 8-1/2"	2
4	TZ75-00-41	WASHER LOCK 3/4"	4
5	TZ75-00-40	NUT, HEX 3/4"	5
6			
7	TC81-00-539	SHAFT, 1-1/2" X 23"	1
8	TM76-00-56	ROLL PIN, 3/8" X 2-1/4"	2
9	402	NUT, HEX 5/8" LOCK	2
10	TZ75-00-75	SPRING	2
11	TZ75-00-121	SPRING BUSHING	4
12	TZ75-00-76	BOLT, HEX 5/8" X 9"	2
13	TZ75-00-87	CLEVIS	2
14	CT84-12	CLEVIS PIN, 5/8" X 2"	2
15	TM76-00-40	CLOTTER PIN	2
16	TZ75-00-77	WASHER, FLAT 5/8"	4
17	CT84-34	BOLT, HEX 5/8" X 7-1/2"	1
18	TC81-00-540	BUSHING	1
19	TC81-00-541	HOUSING	1
20	TM76-00-05	WASHER LOCK 5/8"	1
21	TM76-00-06	NUT, HEX 5/8"	1
22	TC81-00-542	FORK COULTER	1
23	TZ75-00-147	BOLT, HEX 3/4" X 7"	1
24	TZ75-00-140	HUB, COULTER	1
25	TZ75-00-143	BUSHING HUB	1
26	TZ75-00-145	CUP, BEARING	2
27	TZ75-00-144	CONE, BEARING	2
28	TZ75-00-143	DUST SEAL	2
29	TZ75-00-142	SPACER	2
30	TZ75-00-141	BOLT, 3/8" X 1-1/4" CARRIAGE	4
31	TZ75-00-83	NUT, HEX 3/8"	4
32	TZ75-00-180	WASHER, LOCK 3/8"	4
33	TZ75-00-82	COULTER, 18" DIA	1
34	TC81-00-543	STOP	1
35	TC81-00-544	SPACER	1
36	TC81-00-550	CENTER SPACER	1
37	TC81-00-535	SINGLE COULTER ASSY	1
38	TC81-00-135	FRAME, FT. 3 SHANK S.C.	1
39	TC81-00-136	FRAME, FT. 5 SHANK S.C.	1
40	TC81-00-138	FRAME, FT. 7 SHANK S.C.	1
41	TC81-00-139R	FRAME, FT. 30" EXT. S.C.	1
	TC81-00-139L	FRAME, FT. 30" EXT. S.C.	1
42	TC81-00-140L	FRAME, FT. 60" EXT. S.C.	1
	TC81-00-140R	FRAME, FT. 60" EXT. S.C.	1



# SHANK ASSEMBLY

1976-1983

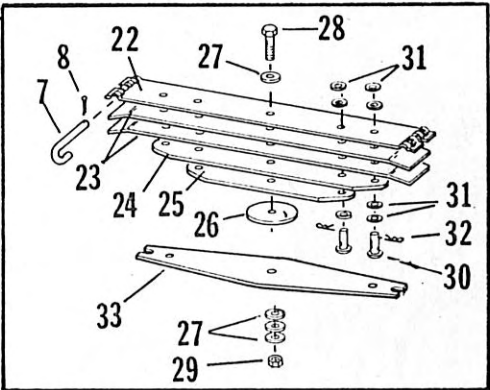
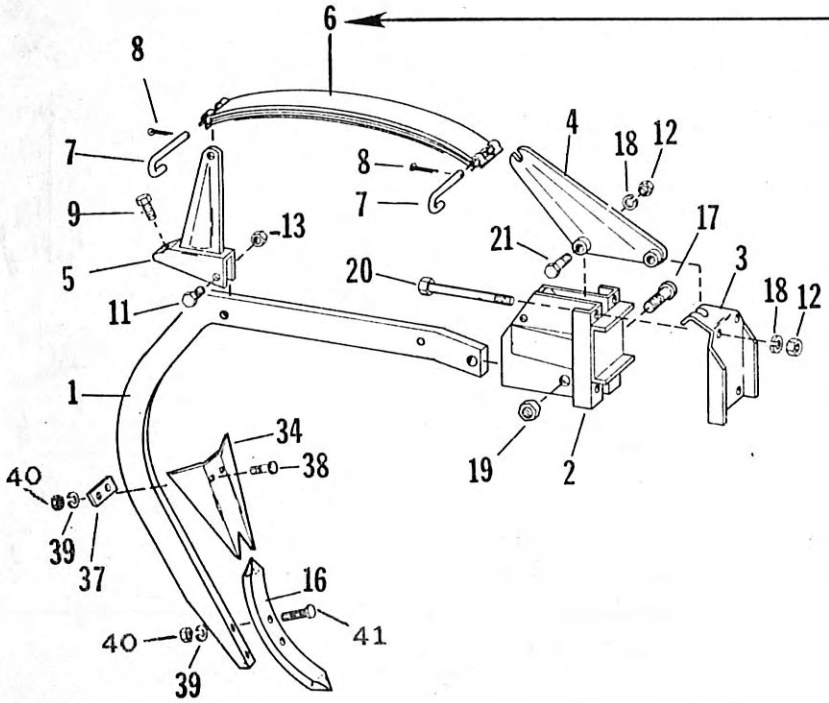

1979 - 1983 SHANK ASSEMBLY

1976 - 1978 SHANK ASSEMBLY

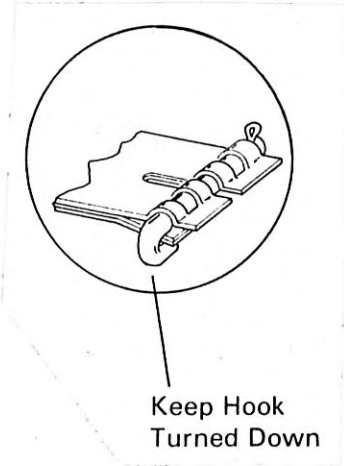

SHANK ASSEMBLY  
1976-1983

REF.	PART NO.	DESCRIPTION	QTY.
1	TM76-00-127	SHANK	1
2	TM76-00-34	BRACKET, MTG.	1
3	TM76-00-35	PLATE, FRONT	1
4	TM76-00-36	ARM, FRONT	1
5	TM76-00-37	ARM, REAR	1
6	TM76-00-38	SPRING, LEAF, COMP.	1
7	TM76-00-39	PIN, SPRING	2
8	TM76-00-40	COTTER PIN	2
9	TM76-00-41	BOLT, ADJUSTING	1
10	TM76-00-05	WASHER, LOCK 5/8"	1
11	TM76-00-42	BOLT, HEX 5/8" X 2-3/4"F	1
12	TM76-00-12	NUT, HEX 3/4"	5
13	TM76-00-43	NUT, HEX 5/8" (LOCK)	1
14	TM76-00-44	BOLT, HEX 5/8" X 3"	2
15	TM76-00-06	NUT, HEX 5/8"	2
16	TM76-00-160	REVERSIBLE POINT W/BOLTS	1
17	TM76-00-46	KING PIN W/ZERK 1" X 3-1/4"	1
18	TM76-00-11	WASHER, LOCK 3/4"	5
19	TM76-00-47	KING PIN NUT, 1"	1
20	TM76-00-13	BOLT, HEX 3/4" X 9-1/2"	1
21	TM76-00-49	BOLT, HEX 3/4" X 3	1
22	TM76-00-81	TOP SPRING LEAF	1
23	TM76-00-82	SPRING LEAF	2
24	TM76-00-83	SPRING LEAF	1
25	TM76-00-84	SPRING LEAF	1
26	TM76-00-85	SPRING LEAF WASHER	1
27	TM76-00-86	WASHER, FLAT 7/16"	4
28	TM76-00-87	BOLT, HEX 7/16" X 2"	1
29	TM76-00-88	NUT, HEX 7/16"	1
30	TM76-00-147	BOLT, 7/16" X 1-1/2	4
31	TM76-00-90	WASHER, FLAT 7/16"	14
32	TM76-00-165	METRIC NUT	4
33	TM76-00-118	HELPER, SPRING LEAF	1
34	TM76-00-123	COVER BLADE ASSY. (PLATE, BLADE, BOLTS)	1
35	TM76-00-33	SHANK (OLD STYLE)	1
36	TM76-00-45	CHISEL PLOW POINT (OLD STYLE)	1
37	TM76-00-149	PLATE	1
38	TM76-00-150	SHOVEL BOLT, 7/16" X 4"	2
39	TM76-00-5	GR. 8, CARRIAGE WASHER, LOCK, 5/8"	4
40	TM76-00-6	NUT, HEX 5/8"	4
41	TZ75-00-54	BOLT, HEX 5/8" X 3"	2

# SHANK ASSEMBLY

1984-1989

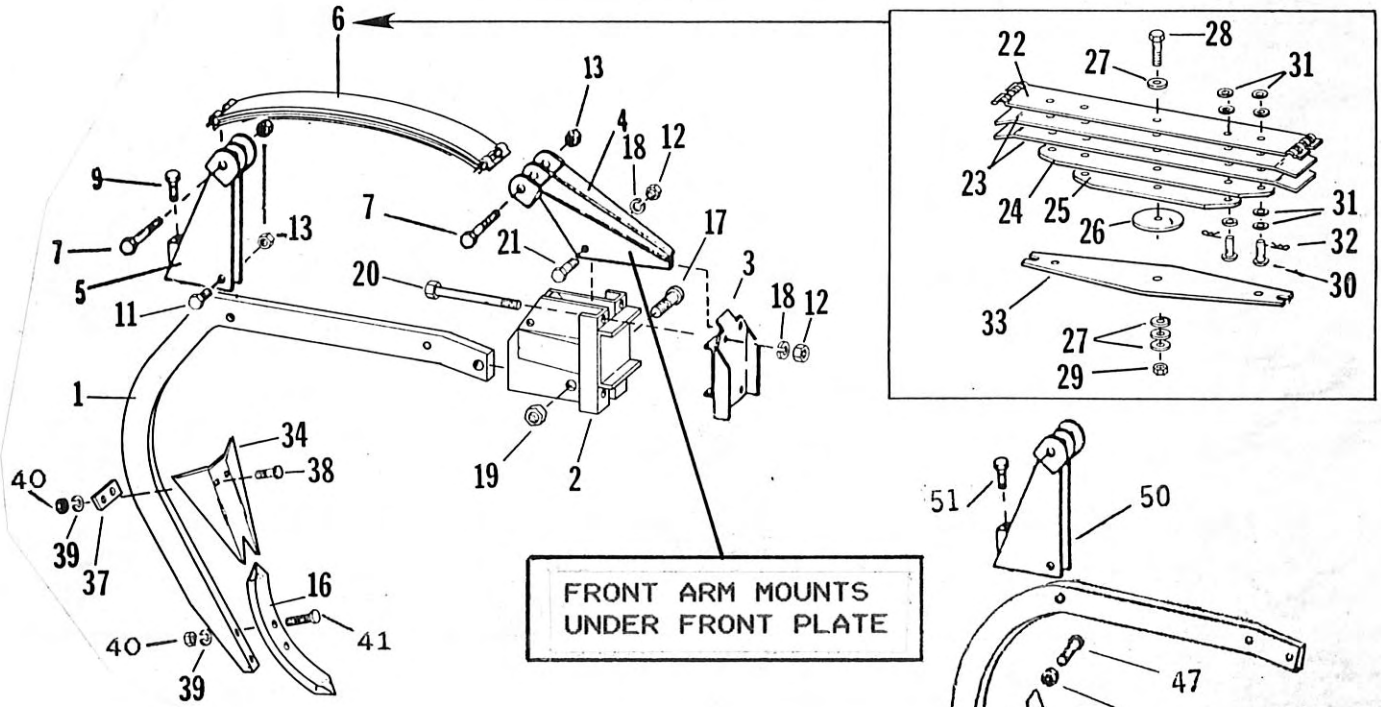

1984 SHANK ASSEMBLY

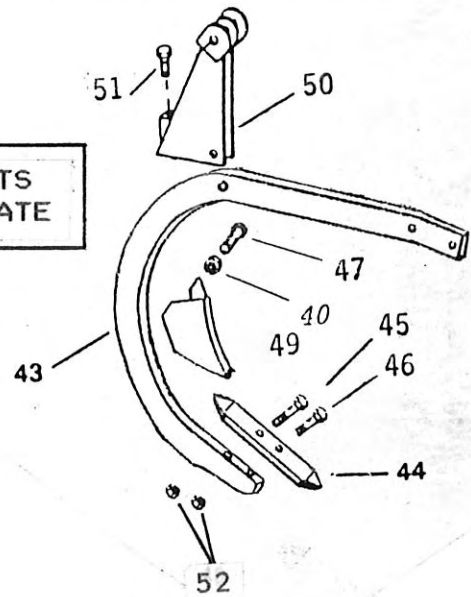

1985 - 1989 SHANK ASSEMBLY

SHANK ASSEMBLY  
1984-1989

REF.	PART NO.	DESCRIPTION	QTY.
1	TM76-00-127	SHANK	1
2	TM76-00-34	BRACKET, MTG.	1
3	TM76-00-166	PLATE, FRONT	1
4	TM76-00-167	ARM, FRONT	1
5	TM76-00-154	ARM, REAR	1
6	TM76-00-38	SPRING, LEAF COMPLETE	1
7	TM76-00-168	BOLT, 5/8" X 7" CARRIAGE	2
9	TM76-00-180	BOLT, 1" X 3" FINE, ADJ.	1
10	TM76-00-05	WASHER, LOCK 5/8"	2
11	TM76-00-42	BOLT, HEX 5/8" X 3"	1
12	TM76-00-12	NUT, HEX 3/4"	5
13	TM76-00-43	NUT, HEX, 5/8" (LOCK)	3
16	TM76-00-120	REVERSIBLE POINT W/BOLTS	1
17	TM76-00-46	KING PIN W/ZERK 1" X 3-1/4"	1
18	TM76-00-11	WASHER, LOCK 3/4"	4
19	TM76-00-47	KING PIN NUT, 1"	1
20	TM76-00-13	BOLT, HEX 3/4" X 9-1/2" GR. 5	1
21	TM76-00-49	BOLT, HEX, 3/4" X 3"	1
22	TM76-00-81	TOP SPRING LEAF	1
23	TM76-00-82	SPRING LEAF	2
24	TM76-00-83	SPRING LEAF	1
25	TM76-00-84	SPRING LEAF	1
26	TM76-00-85	SPRING LEAF WASHER	1
27	TM76-00-86	WASHER, FLAT	4
28	TM76-00-87	BOLT, HEX 7/16" X 2"	1
29	TM76-00-88	NUT, HEX 7/16"	1
30	TM76-00-147	BOLT, 7/16" X 1-1/2"F	4
31	TM76-00-90	WASHER, FLAT	14
32	TM76-00-165	METRIC NUT	4
33	TM76-00-118	HELPER, SPRING LEAF	1
34	TM76-00-123	COVER BLADE ASSY. (PLATE, BLADE, BOLTS)	1
37	TM76-00-149	PLATE	1
38	TM76-00-150	CARRIAGE BOLT, 7/16" X 4"	2
39	TM76-00-5	5/8" LOCKWASHER	4
40	TM76-00-6	5/8" HEX NUT	5
41	TZ75-00-54	BOLT, HEX 5/8" X 3"	1
42	TM76-00-44	BOLT, 5/8" X 3-1/4" HEX	1
43	TM76-00-175	SHANK, 1985	1
44	TM76-00-176	POINT, 1985 REVERSIBLE	1
45	TM76-00-181	BOLT, 3" METRIC	1
46	TM76-00-182	BOLT, 2-1/2" METRIC	1
47	TM76-00-179	BOLT, 5/8" X 3" CARRIAGE	1
48	TM76-00-183	NUT, METRIC	1
49	TM76-00-178	COVERING BLADE, 1985	1
50	TM76-00-184	ARM, REAR	1
51	TM76-00-170	BOLT, 4-1/4" METRIC	1
52	TM76-00-183	NUT METRIC	2



# SHANK ASSEMBLY 1990 AND NEWER

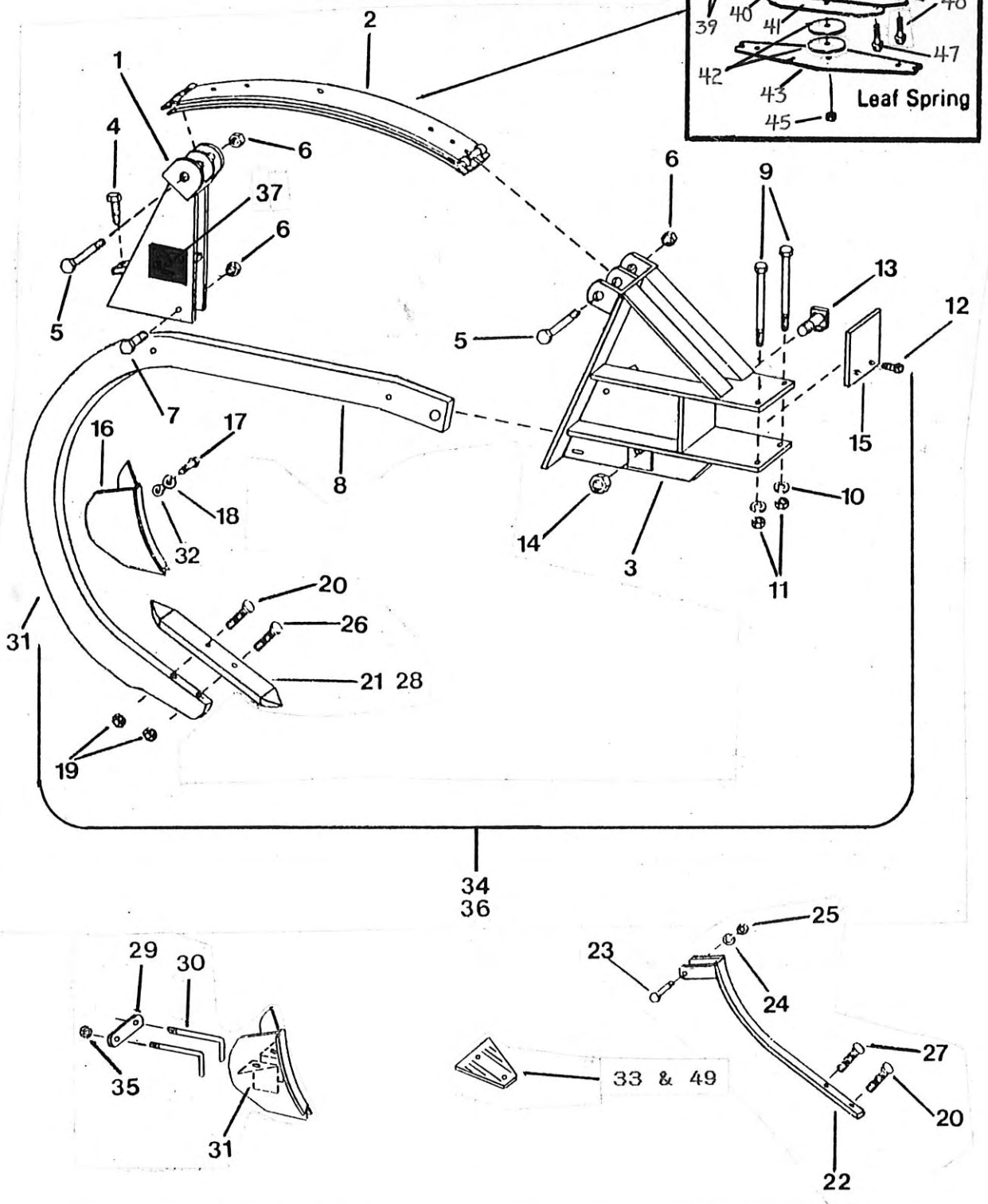

**NOTE: COMPLETE SHANK ASSEMBLY DOES NOT INCLUDE OPTIONAL COVERBOARDS, WEAR PLATES, OR THE POINT LIFTER PLATE.**

SHANK ASSEMBLY  
1990 AND NEWER

REF.	PART NO.	DESCRIPTION	QTY.
1	TM76-00-154	REAR ARM	1
2	TM76-00-38	SPRING LEAF COMPLETE	1
3	TM76-250	BRACKET, MOUNT	1
4	TM76-00-170	ADJUSTING BOLT, 2.5 MM X 3"	1
5	TM76-00-168	BOLT, CARRIAGE, 5/8" X 7"	2
6	TM76-00-43	LOCK NUT, 5/8"	3
7	TM76-00-42	HEX BOLT, 5/8" X 3"	1
8	TM76-00-175	SHANK	1
9	TM76-00-18	BOLT, HEX 3/4" X 7"	2
10	TM76-00-11	LOCK WASHER, 3/4"	2
11	TM76-00-12	HEX NUT, 3/4"	2
12	TM76-252	SET SCREW, 5/8" X 1-1/2"	2
13	TM76-251	KINGPIN W/ ZERK, 1" X 4"	1
14	TM76-00-47	KINGPIN NUT	1
15	TM76-253	PLATE, FRONT	1
16	TM76-00-178	COVERBOARD	1
17	TM76-00-179	CARRIAGE BOLT, 5/8" X 3"	1
18	TM76-00-5	LOCKWASHER 5/8"	1
19	TM76-00-183	NUT METRIC	2
20	TM76-00-181	SHOVEL BOLT, 3" METRIC	1
21	TM76-00-176	REVERSIBLE POINT (WITH BOLTS)	1
22	TM76-00-197	WEAR STRAP (OPTIONAL)	1
23	1413	HEX BOLT, 3/8" X 2-1/2"	1
24	TZ75-00-180	LOCK WASHER, 3/8"	1
25	TZ75-00-83	HEX NUT, 3/8"	1
26	TM76-00-182	SHOVEL BOLT, 2-1/2" METRIC	1
27	TM76-00-199	SHOVEL BOLT, 3-1/2" METRIC	1
28	TM76-201	REVERSIBLE POINT (LESS BOLTS)	1
29	TM76-272	PLATE	1
30	TM76-271	MOUNTING BOLT	2
31	TM76-270	COVERBLADE (OPTIONAL) (FOR INTERNATIONAL & JOHN DEERE)	1
32	TZ75-00-63	5/8" HEX NUT	1
33	TM76-977	7" LIFTER PLATE	1
34	TM76-249	NEED 1 (TM76-00-199) BOLT NOT INCLUDED 2 SHANK ADD ON ASSY 90 & NEWER	1
35	402	LOCKNUT 1/2"	2
36	TM76-248	SHANK ADD ON ASSY COMPLETE	1
37	TM76-22	CAMBER DECAL	2
38	TM76-00-81	TOP SPRING LEAF	1
39	TM76-00-82	SPRING LEAF	2
40	TM76-00-83	SPRING LEAF	1
41	TM76-00-84	SPRING LEAF	1
42	TM76-00-85	SPRING LEAF WASHER	2
43	TM76-00-118	HELPER SPRING LEAF	1
44	TM76-00-87	BOLT, METRIC, M12X65MM, CLASS 8.8	1
45	TM76-00-88	NUT, METRIC, M12	1
46	TM76-00-165	NUT, METRIC, FLANGE LOCK M10	4
47	TM76-00-147	BOLT, METRIC, M10 X 34MM	2
48	TM76-00-148	BOLT, METRIC, M10 X 30.5MM	2
49	TM76-978	13" LIFTER PLATE - NEED 1 (TM76-00-199) BOLT NOT INCLUDED	1

# Optional Ridge Ripper

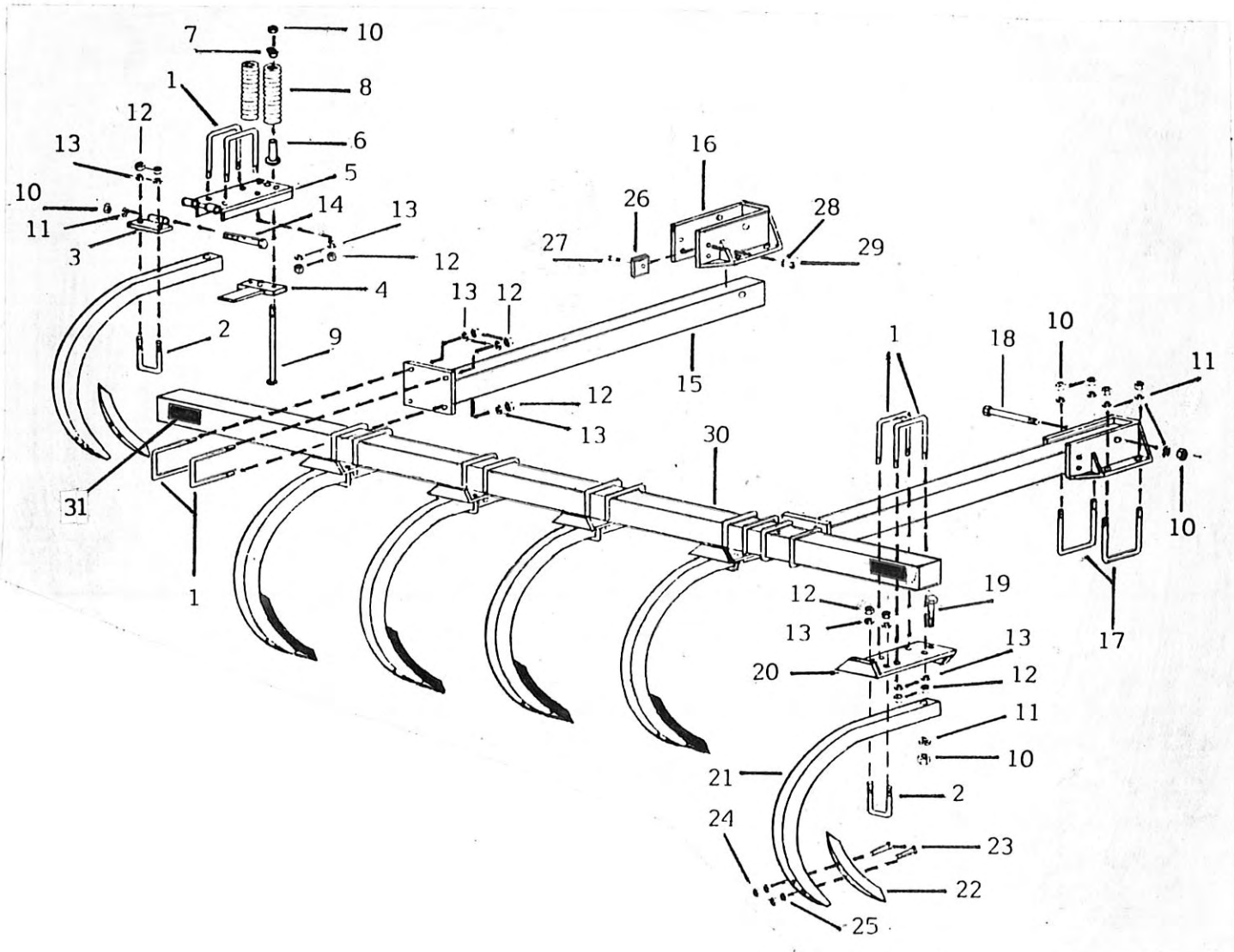

RIDGE RIPPER

REF.	PART NO.	DESCRIPTION	QTY.
1	RR88-630	U-BOLT, 5/8" X 4-1/2 X 3" X 4-1/2"	16
2	CT84-25	U-BOLT, 5/8" X 2-1/2" X 2" X 2-1/2"	6
3	RR88-520	HINGE	6
4	RR88-400	SHANK PLATE	6
5	RR88-500	SPRING LOADED SHANK BKT.	6
6	RR88-540	SPRING BUSHING, LONG	12
7	CT84-10	SPRING BUSHING, SHORT	12
8	CT84-11	SPRING	12
9	CT84-9	BOLT, HEX 3/4" X 13-1/2"	12
10	TM76-00-12	NUT, HEX 3/4"	28
11	TM76-00-11	WASHER, LOCK 3/4"	14
12	TM76-00-06	NUT, HEX 5/8"	44
13	TM76-00-05	WASHER, LOCK 5/8"	44
14	TZ75-00-147	BOLT, HEX 3/4" X 7"	6
15	RR88-200	PULL ARM	2
16	RR88-100	MOUNTING BRACKET	2
17	TZ75-00-23	U-BOLT, 3/4" X 6-1/2" X 7" X 6-1/2"	4
18	RR88-640	BOLT, HEX 3/4" X 4-1/2	2
19	RR88-650	BOLT, HEX 3/4"	6
20	RR88-300	RIGID SHANK BRACKET	6
21	CT84-22	SHANK	6
22	RR88-600	SHOVEL, REV. PNT 2" X 16"	6
23	CT84-40	BOLT, SHOVEL 7/16" X 2-1/2"	12
24	TZ75-00-30	NUT, HEX 7/16"	12
25	RR88-620	WASHER, LOCK 7/16"	12
26	RR88-230	ADJUSTING PLATE	4
27	CT84-82	BOLT, HEX 1/2" X 1-1/2"	4
28	TM76-00-151	WASHER, LOCK 1/2"	4
29	TM76-00-152	NUT, HEX 1/2"	4
30	RR88-148	TUBE, 10 SHANK MODEL	2
	RR88-160	TUBE, 6 SHANK MODEL	1
	RR88-160	TUBE, 8 SHANK MODEL	1
31	TM76-20	REFLECTOR RED	2



# OPTIONAL EQUIPMENT

## POLE HITCH

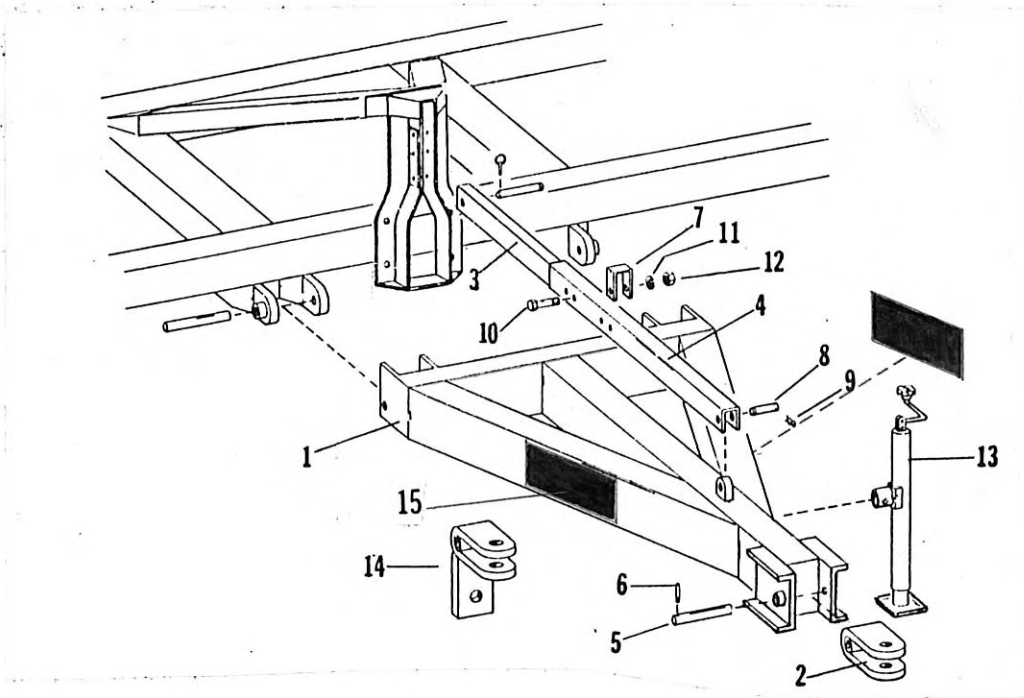

REF.	PART NO.	DESCRIPTION	QTY.
1	TM76-00-50	POLE	1
2	TM76-00-51	CLEVIS HITCH	1
3	TM76-00-52	ARM, INNER	1
4	TM76-00-53	ARM, OUTER	1
5	TM76-00-54	CLEVIS, PIN	1
6	TM76-00-56	3/8" X 2-1/4" ROLL PIN	1
7	TM76-00-57	HOSE BRACKET	1
8	TM76-00-125	PIN, CYLINDER	1
9	TM76-00-126	HAIRPIN, COTTER	2
10	TM76-00-58	BOLT, HEX 5/8" X 3-1/2"	2
11	TM76-00-05	WASHER, LOCK 5/8"	2
12	TM76-00-06	NUT, HEX 5/8"	2
13	TSS81-00-25	JACK	1
14	TM76-00-155	CAT HITCH	1
15	TM76-12	TEBBEN DECAL 4 1/2" X 9"	2

# OPTIONAL EQUIPMENT

## EXTENSIONS

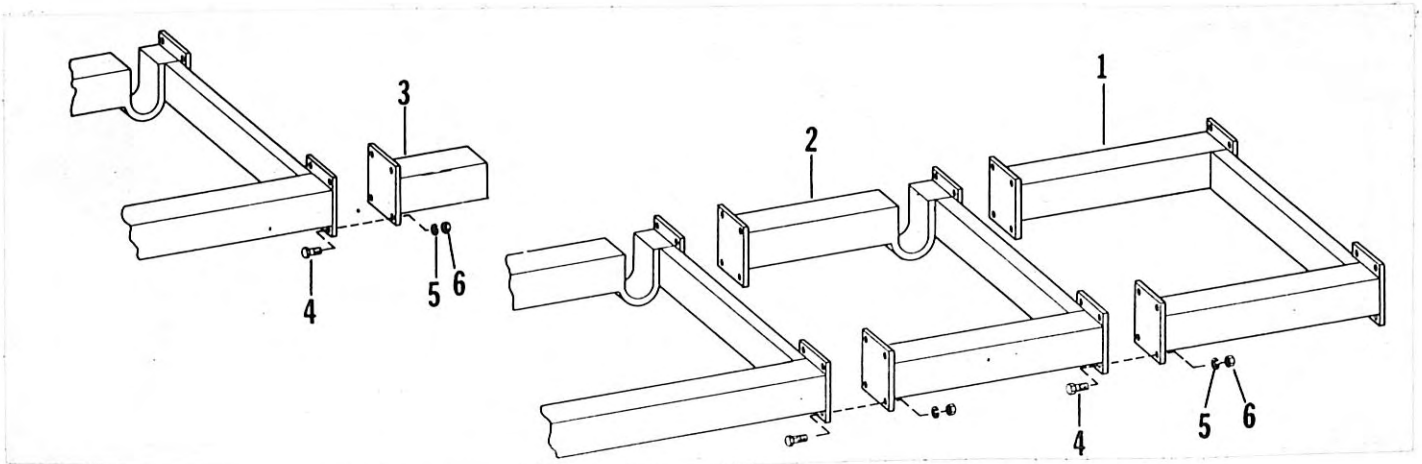

REF.	PART NO.	DESCRIPTION	QTY.
1	TM76-00-77	DOUBLE EXTENSION, 30" F	1
2	TM76-00-78	DOUBLE DROP THRU EXTENSION 30"	6
3	TM76-00-79	SINGLE EXTENSION, 12"	1
4	TM76-00-80	BOLT, HEX, 3/4" X 2"	X
5	TM76-00-11	WASHER, LOCK, 3/4"	X
6	TM76-00-12	NUT, HEX, 3/4"	X

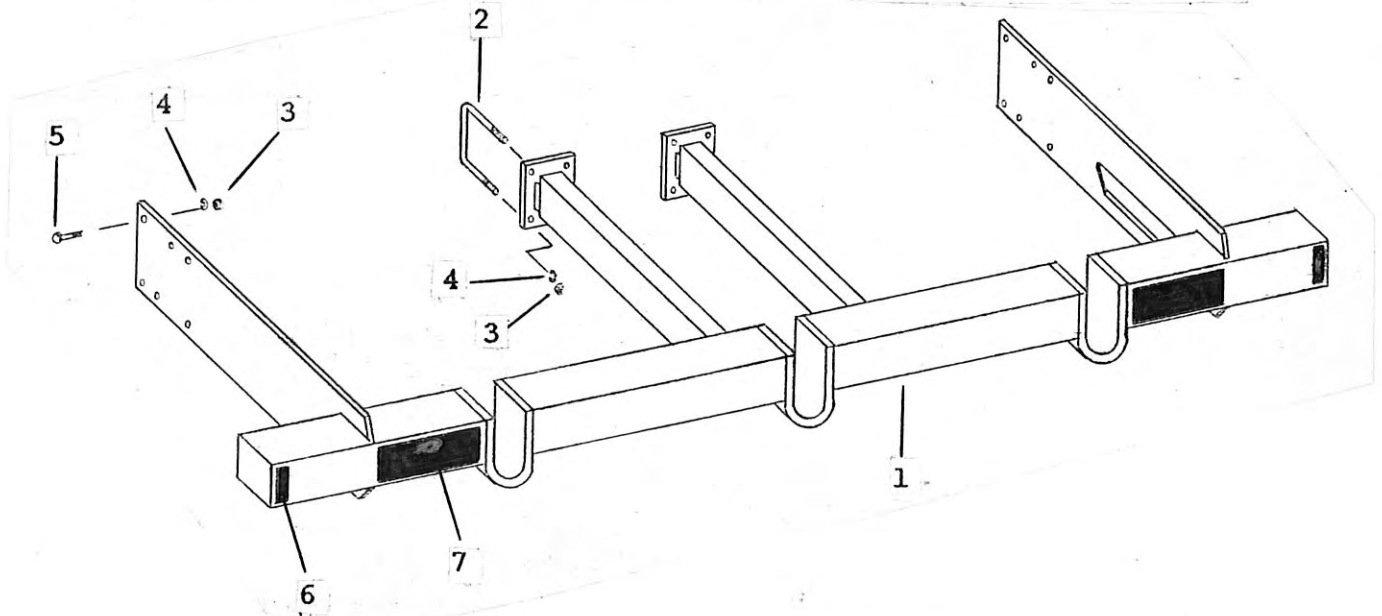

### 7 SHANK 24" FRAME CONVERSION KIT

REF.	PART NO.	DESCRIPTION	QTY.
1	TM76-00-260	CONVERSION FRAME	1
2	TZ75-00-24	U-BOLT 3/4" X 8-1/2" X 5" X 8-1/2"	4
3	TM76-00-12	HEX NUT 3/4"	12
4	TM76-00-11	LOCKWASHER 3/4"	12
5	TM76-00-80	HEX BOLT 3/4" X 2"	4
6	TM76-20	REFLECTOR (RED)	2
7	TM76-12	TEBBEN DECAL 4 1/2" X 9"	2

# TEBBEN Levelator Assembly

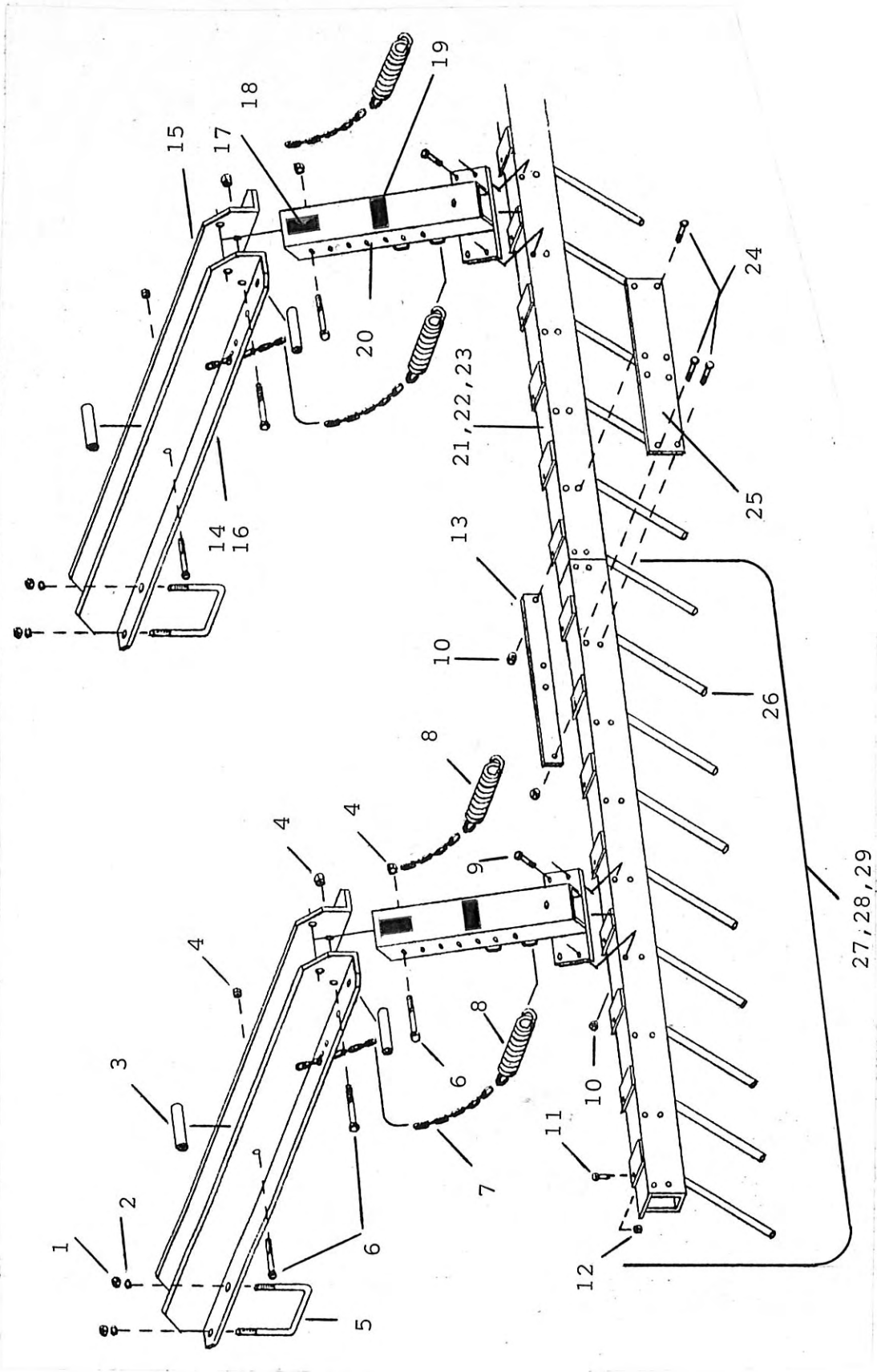

OPTIONAL LEVELATOR

REF.	PART NO.	DESCRIPTION	QTY.
1	TM76-00-12	HEX NUT 3/4"	8
2	TM76-00-11	LOCKWASHER 3/4"	8
3	8-542	SPACER TUBE	4
4	CT84-141	LOCKNUT 3/4"	6
5	TZ75-00-23	U-BOLT 3/4"X 6 1/2"X7"X6 1/2"	4
6	TZ75-00-43	HEX BOLT 3/4" X 6 1/2"	6
7	8-528	CHAIN (18 LINKS )	4
8	8-572	PRESSURE SPRING	4
9	710	HEX BOLT 1/2" X 3"	8
10	402	LOCKNUT 1/2"	16
11	2109-802	HEX BOLT 1/2" X 1"	14,16,18
12	402	LOCKNUT 1/2"	14,16,18
13	8-521	CONNECTOR PLATE (REAR)	1
14	8-541L	ANGLE MOUNT L.H. (CHISEL PLOW)	2
15	8-541R	ANGLE MOUNT R.H. (CHISEL PLOW)	2
16	8-540L	ANGLE MOUNT L.H. (DEEP TILL)	2
17	8-540R	ANGLE MOUNT R.H. (DEEP TILL)	2
18	TM76-20	REFLECTOR (RED)	2
19	TM76-11	TEBBEN DECAL 2" X 4"	2
20	8-529	SWING ARM	2
21	8-570	LEVELATOR BAR 70"	2
22	8-580	LEVELATOR BAR 80"	2
23	8-590	LEVELATOR BAR 90"	2
24	CT84-31	HEX BOLT 1/2" X 3 1/2"	8
25	8-522	CONNECTOR PLATE (FRONT)	1
26	8-510	LEVELATOR TOOTH	14,16,18
27	8-571	LEVELATOR BAR WITH TEETH 70"	1
28	8-581	LEVELATOR BAR WITH TEETH 80"	1
29	8-591	LEVELATOR BAR WITH TEETH 90"	1



# HYDRAULIC CYLINDER

1976-1989

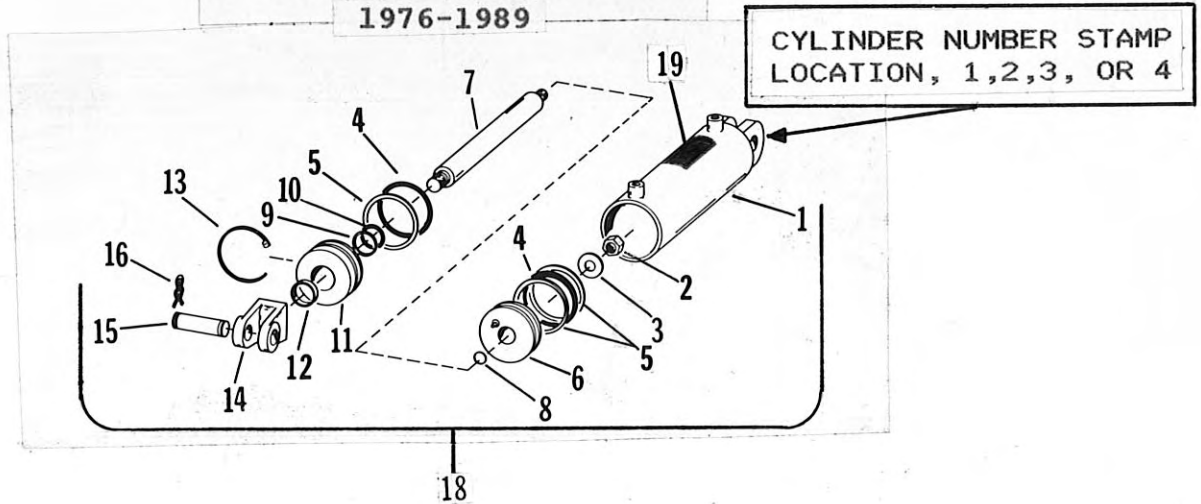

## WELDED HYDRAULIC CYLINDER 1976-1989

REF.	PART NO.	DESCRIPTION	QTY.
1	TM76-00-93	CYLINDER HOUSING	1
2	TM76-00-94	LOCK NUT	1
3	TM76-00-95	WASHER, FLAT	1
4		O-RING (IN PARTS KIT)	2
5		SEAL, BACKUP	1
6	TM76-00-98	PISTON W/POPPET	1
7	TM76-00-99	SHAFT #1 & #2 - 010700160	1
	TM76-00-299	SHAFT #3 & #4 - 010600080	1
8		O-RING	1
9		SEAL, BACKUP	1
10		O-RING	1
11	TM76-00-104	HEAD, CYLINDER	1
12		WIPER	1
13	TM76-00-106	SNAP RING	1
	TM76-00-107	CLEVIS	1
15	TM76-00-108	CYLINDER PIN	1
16	TM76-00-109	HAIR PIN, COTTER	2
17	TM76-00-103	SEAL KIT #1 CYLINDER R11-21	1
	TM76-00-103	SEAL KIT #2 CYLINDER R11-28	1
	TM76-00-103	SEAL KIT #3 CYLINDER R11-22	1
	TM76-00-103	SEAL KIT #4 CYLINDER R11-29	1
18	TM76-00-60	HYDR. CYLINDER COMPLETE 4"	1
	TM76-00-61	HYDR. CYLINDER COMPLETE 3 3/4"	1
	TM76-00-62	HYDR. CYLINDER COMPLETE 3 1/2"	1
	TM76-00-63	HYDR. CYLINDER COMPLETE 3 1/4"	1
19	TM76-23	SERIES SYSTEMS DECAL	1

NOTE: WHEN ORDERING CYLINDER REPAIR PARTS, STATE THE NO. OF CYLINDER (SAMPLE: CYLINDER #2)

# HYDRAULIC CYLINDER

1990-1994

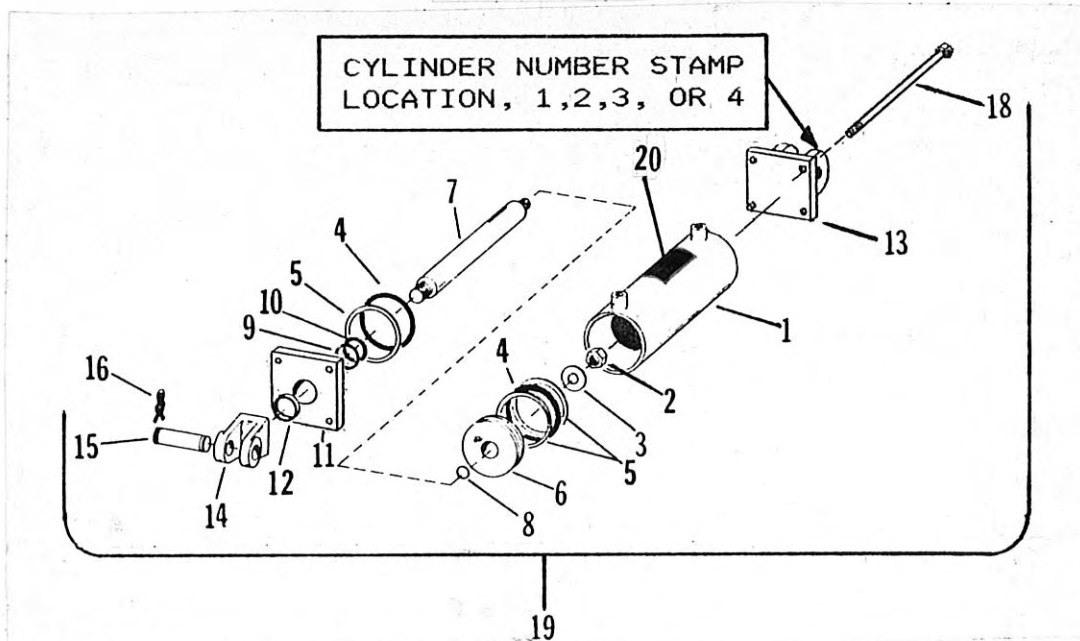

## TIE ROD HYDRAULIC CYLINDER

1990-1994

REF.	PART NO.	DESCRIPTION	QTY.
1	TM76-401	CYLINDER HOUSING	1
2	TM76-00-94	LOCK NUT	1
3	TM76-00-95	WASHER, FLAT	1
4		O-RING (IN PARTS KIT)	2
5		SEAL BACKUP (IN PARTS KIT)	1
6	TM76-402	PISTON WITH POPPET	1
7	TM76-403	SHAFT #1 & #2 - 010700504	1
	TM76-603	SHAFT #3 & #4 - 010600324	1
8		O-RING (IN PARTS KIT)	1
9		SEAL, BACKUP (IN PARTS KIT)	1
10		O-RING (IN PARTS KIT)	1
11	TM76-404	HEAD, CYLINDER	1
12		WIPER (IN PARTS KIT)	1
13	TM76-405	END, CYLINDER	1
14	TM76-406	CLEVIS	1
15	TM76-00-108	CYLINDER PIN	1
16	TM76-00-109	HAIR PIN, COTTER	2
17	TM76-450	SEAL KIT #1 CYLINDER AJ251	1
	TM76-450	SEAL KIT #2 CYLINDER AJ252	1
	TM76-450	SEAL KIT #3 CYLINDER AJ253	1
	TM76-450	SEAL KIT #4 CYLINDER AJ254	1
18	TM76-407	TIE ROD	4
19	TM76-460	HYDRAULIC CYLINDER COMPLETE #1	1
	TM76-461	HYDRAULIC CYLINDER COMPLETE #2	1
	TM76-462	HYDRAULIC CYLINDER COMPLETE #3	1
	TM76-463	HYDRAULIC CYLINDER COMPLETE #4	1
20	TM76-23	SERIES SYSTEMS DECAL	1

NOTE: WHEN ORDERING CYLINDER REPAIR PARTS, STATE THE NO. OF CYLINDER (SAMPLE: CYLINDER #2)

# HYDRAULIC CYLINDER 1995 & NEWER

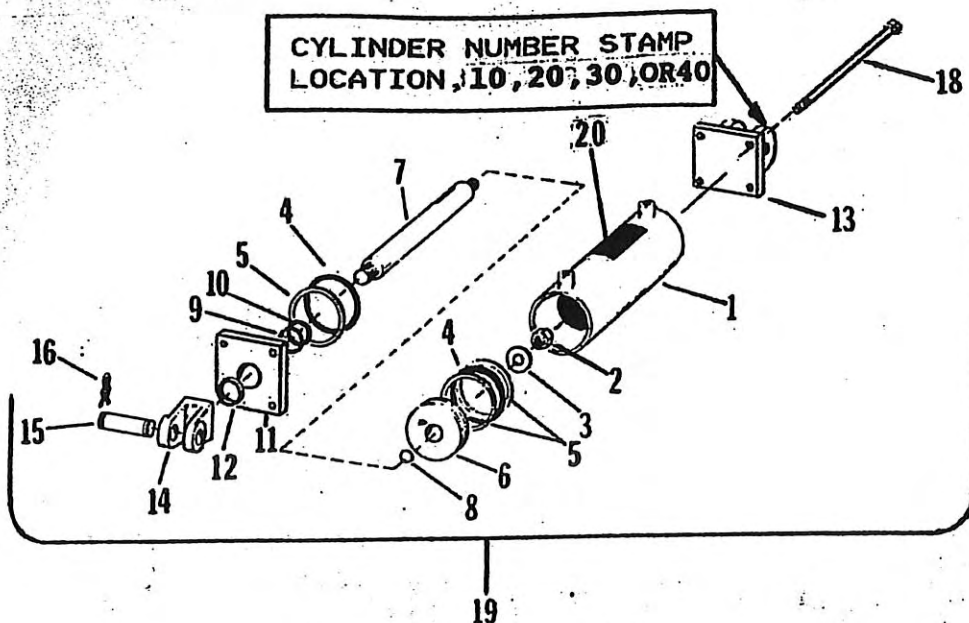

## TIE ROD HYDRAULIC CYLINDER 1995 & NEWER

REF.	PART NO.	DESCRIPTION	QTY.
1	TM76-501	CYLINDER HOUSING #1 - 061900598	1
2	TM76-00-94	LOCK NUT 220000210	1
3	TM76-00-95	WASHER, FLAT	1
4		O-RING (IN PARTS KIT)	2
5		SEAL BACKUP (IN PARTS KIT)	1
6	TM76-502	PISTON WITH POPPET #1-071900273	1
7	TM76-503	SHAFT, CYLINDER #1-010700806	1
8		O-RING (IN PARTS KIT)	1
9		SEAL, BACKUP (IN PARTS KIT)	1
10		O-RING (IN PARTS KIT)	1
11	TM76-504	HEAD, CYLINDER #1-081900425	1
12		WIPER (IN PARTS KIT)	1
13	TM76-505	END, CYLINDER #1-141900096	1
14	TM76-406	CLEVIS #1-100000330	1
15	TM76-00-108	CYLINDER PIN 190400004	1
16	TM76-00-109	HAIR PIN, COTTER	2
17	TM76-550-1	SEAL KIT #1 CYLINDER AR574	1
	TM76-550-2	SEAL KIT #2 CYLINDER AR575	1
	TM76-550-3	SEAL KIT #3 CYLINDER	1
	TM76-550-4	SEAL KIT #4 CYLINDER	1
18	TM76-407	TIE ROD 170301172	4
19	TM76-560	HYDRAULIC CYLINDER COMPLETE #10	1
	TM76-561	HYDRAULIC CYLINDER COMPLETE #20	1
	TM76-562	HYDRAULIC CYLINDER COMPLETE #30	1
	TM76-563	HYDRAULIC CYLINDER COMPLETE #40	1
20	TM76-23	SERIES SYSTEMS DECAL	1
21	TM76-00-187	<i>Repack Grease Kit</i>	

NOTE: WHEN ORDERING CYLINDER REPAIR PARTS, STATE THE NO. OF CYLINDER (SAMPLE: CYLINDER #10)



# DISC LEVELER

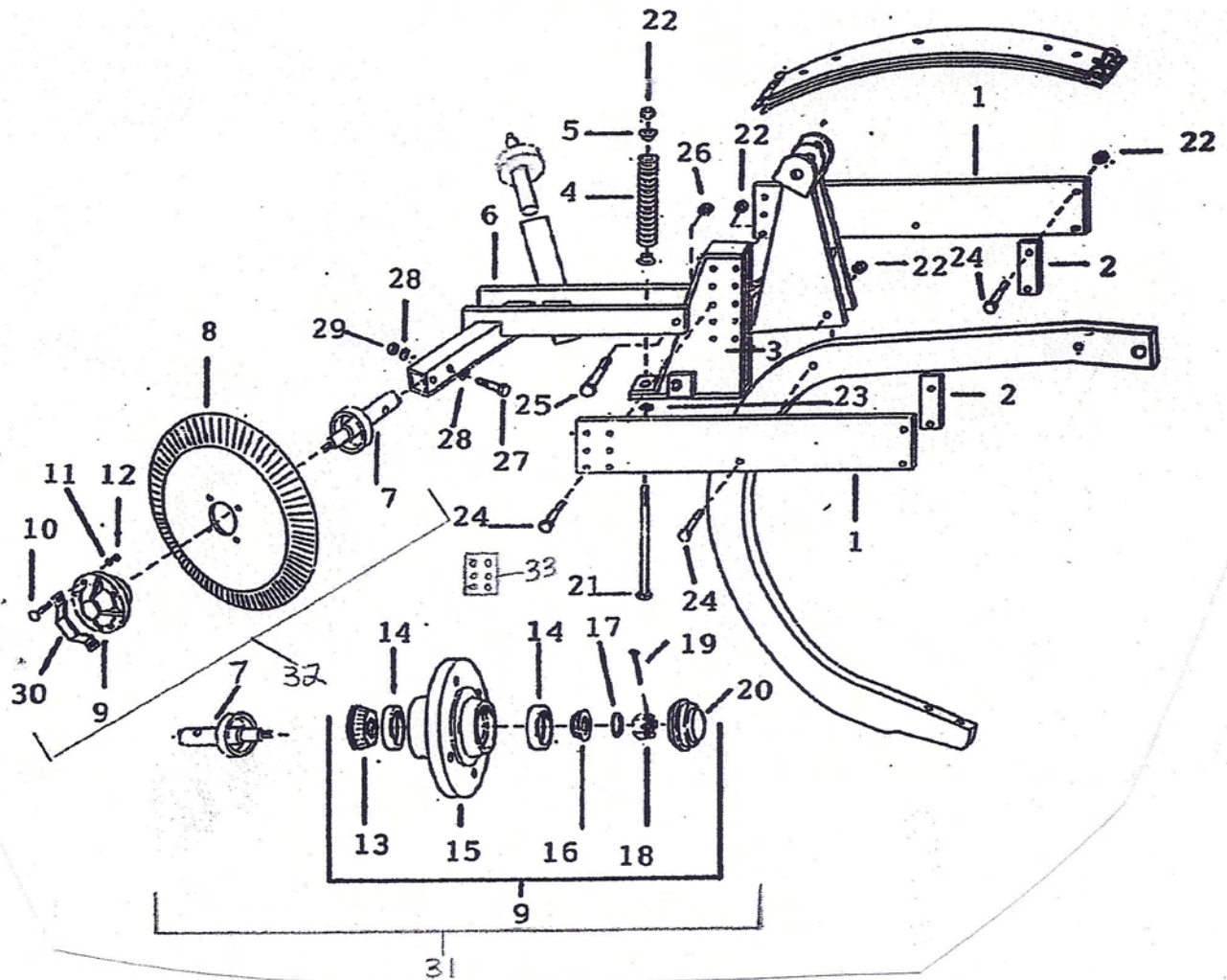

REF.	PART NO.	DESCRIPTION	QTY
1	8-6760	MOUNTING PLATE	2
2	8-677	SPACER PLATE	2
3	8-6600	UPRIGHT MOUNTING BKT	1
4	8-6700	COMPRESSION SPRING	1
5	8-6606	SPRING BUSHING	2
6	8-6500	DISC LEVELER FRAME	1
7	8-720	SPINDLE	2
8	8-7016	HARROW DISK - 19-1/2"	2
9	8-700	HUB (COMPLETE)	2
10	8-7013	BOLT, CARRIAGE 1/2 X 1-1/2"	8
11	8-7014	WASHER, LOCK 1/2"	8
12	8-7015	NUT, HEX 1/2"	8
13	8-702	SEALED CONE BEARING INNER	2
14	8-704	BEARING CUP	4
15	8-701	HUB, FOUR BOLT	2
16	8-703	CONE BEARING OUTER	2
17	8-7060	WASHER	2
18	8-723	NUT, SLOTTED 5/8"	2
19	8-724	COTTER PIN-5/32 X 1-1/2	2
20	8-7062	DUST CAP-DC13	2
21	8-6610	BOLT, HEX 5/8 X 9-1/2	1
22	8-6611	HEX NUT, CENTERLOCK 5/8"	10
23	8-656	FLATWASHER, 5/8	1
24	8-7022	BOLT, HEX 5/8 X 4	9
25	8-658	BOLT, CARRIAGE 3/4 X 5	1
26	8-659	HEX NUT, CENTERLOCK 3/4	1
27	8-680	BOLT, HEX 1/2 X 3	2
28	8-681	FLATWASHER, 1/2	4
29	8-682	HEX NUT, CENTERLOCK 1/2	2
30	8-705	DUST CAP RETAINER	2
31	8-720HC	SPINDLE & HUB COMPLETE	2
32	8-720HBC	SPINDLE, HUB & BLADE COMPLETE	2
33	8-678	SPACER PLATE	OPT.