

ENGLISH

Hakki Pilke 42 Easy

FIREWOOD PROCESSOR
SPARE PARTS MANUAL

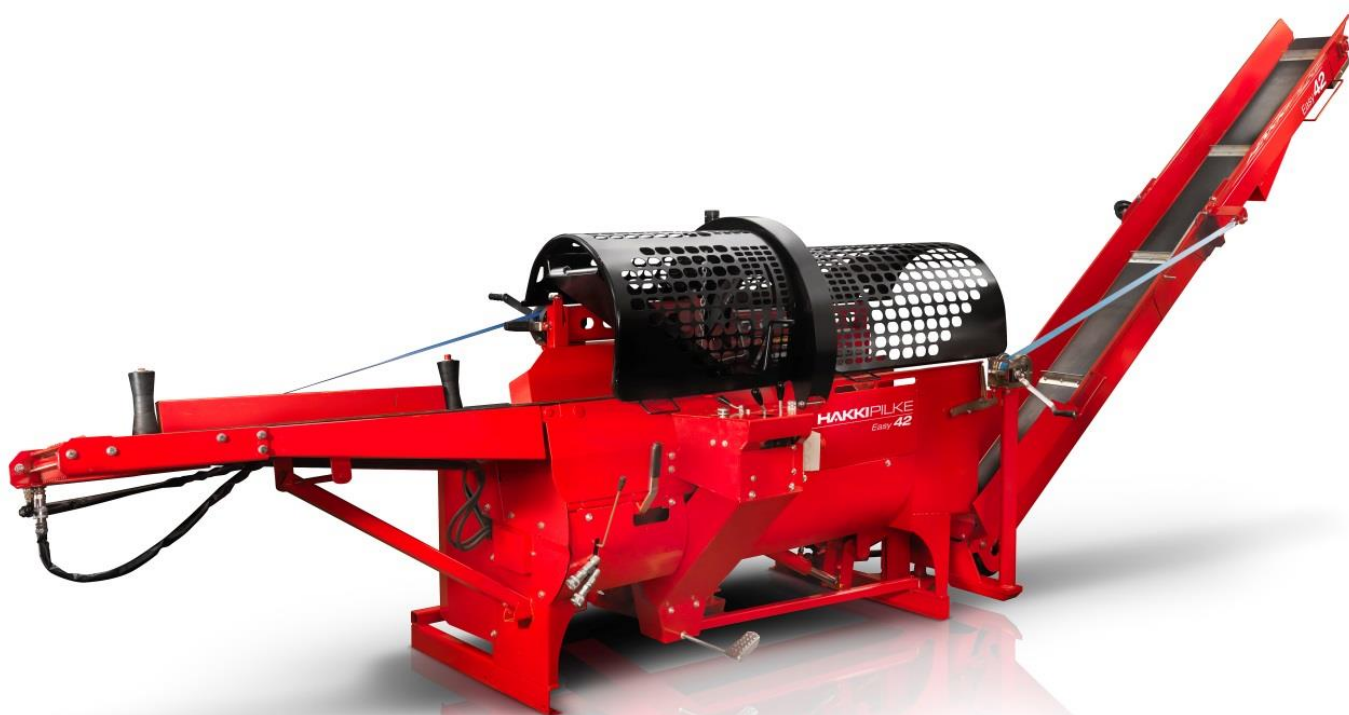

MAASELÄN KONE OY
Valimotie 1, 85800 Haapajärvi
tel.08-7727300, fax.08-7727320
info@maaselankone.fi
www.maaselankone.fi

Table of contents

1.1	Output conveyor (50016893)	4
1.2	Output conveyor parts list (50016893)	5
1.3	Upper section of the output conveyor, assembly	6
1.4	Upper section of the output conveyor, parts list	7
1.5	Output conveyor drive roller kit (50017863)	8
1.6	Output conveyor drive roller parts list (50017863).....	9
1.7	Output conveyor debris removal (50016903).....	10
1.8	Output conveyor debris removal, parts list (50016903)	11
1.9	Output conveyor debris removal, upper section (10831).....	12
1.10	Output conveyor debris removal, upper section parts list (10831)	13
1.11	Output conveyor swivel cylinder, parts list (11160).....	14
1.12	Output conveyor swivel cylinder, parts list (11160).....	14
1.13	Splitting blade lift cylinder (60915)	15
1.14	Splitting blade lift cylinder (60915)	15
1.15	Cutting blade cylinder (61095)	16
1.16	Cutting blade cylinder parts list (61095)	16
1.17	Splitting cylinders (61112 + 61116)	17
1.18	Splitting cylinders parts list (61112 + 61116)	17
1.19	Slide pack (61502)	18
1.20	Slide pack parts list (61502).....	19
1.21	Frame.....	20
1.22	Frame parts list.....	21
1.23	Log rack (60180)	22
1.24	Log rack parts list (60180)	23
1.25	Log rack extension (60950).....	24
1.26	Log rack extension parts list (60950).....	25
1.27	Lever stand (60835).....	26
1.28	Viputelineen osaluettelo (60835).....	27
1.29	Valve mechanism (61130)	28
1.30	Valve mechanism parts list (61130)	29
1.31	Output conveyor swivel device	30
1.32	Output conveyor swivel device parts list	30
1.33	Automatic speed valve(60812).....	31
1.34	Automatic speed valve parts list(60812).....	31

1.35	Blade drive end (61247)	32
1.36	Blade drive end parts list (61247).....	32
1.37	Blade drive end (50005773)	33
1.38	Blade drive end parts list (50005773).....	33
1.39	Cutting assembly	34
1.40	Cutting assembly parts list.....	34
1.41	Angle gear + pump, TR model (61253).....	35
1.42	Angle gear + pump, TR model parts list (61253)	35
1.43	Angle gear + pump, Combi model (61313).....	36
1.44	Angle gear + pump, Combi model parts list (61313).....	36
1.45	Electric motor + extension shaft, Combi model (61316).....	37
1.46	Electric motor + extension shaft, Combi model parts list (61316).....	37
1.47	Electric motor, Combi model (61340)	38
1.48	Electric motor, Combi model parts list (61340)	38
1.49	Power transmission kit, Combi model.....	39
1.50	Power transmission kit, Combi model parts list.....	39
1.51	Electric motor + pump, electric model (61254).....	40
1.52	Electric motor + pump, electric model parts list (61254).....	40
1.53	Norway electric motor + pump (61256)	41
1.54	Norway electric motor + pump parts list(61256)	41
1.55	Log length limiter (61323)	42
1.56	Log length limiter parts list(61323)	42
1.57	Optical wood measuring device	43
1.58	Optical wood measuring device parts list	43
1.59	Log guide + splitting blades	44
1.60	Log guide + splitting blades parts list	44
1.61	Front cage, log press (60451) + rear cage (60460)	45
1.62	Front cage, log press (60451) + rear cage (60460)	45
1.63	Oil tank + upper guard.....	46
1.64	Oil tank + upper guard parts list.....	46
1.65	Cutting chain oil pump (50027370)	47
1.66	Cutting chain oil pump parts list (50027370)	47

1.1 Output conveyor (50016893)

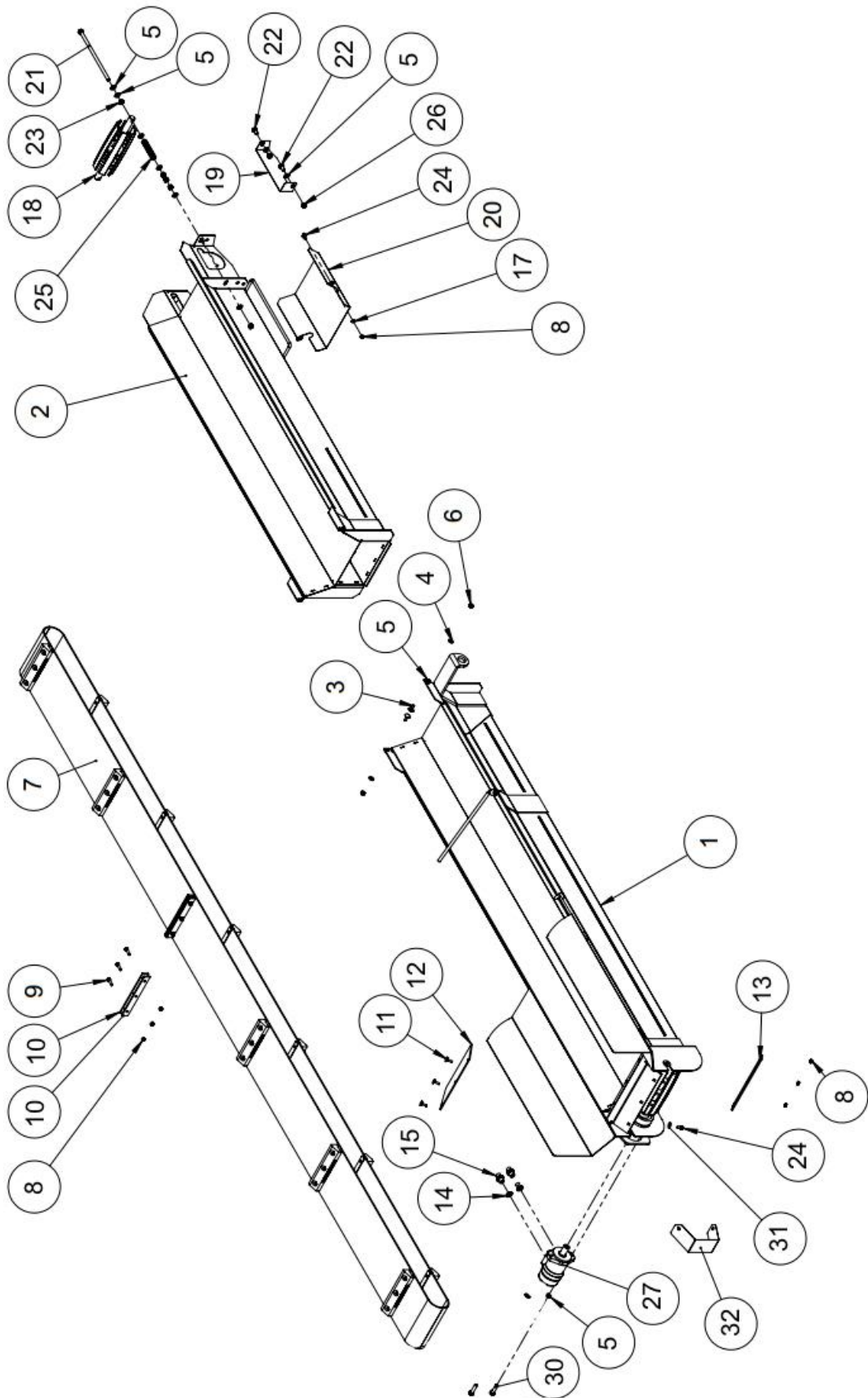

1.2 Output conveyor parts list (50016893)

Number	Name	Part number	Dimensions	Pcs
1	Lower section of the conveyor	50016890		1
2	Upper section of the conveyor	10126		1
3	Lock screw	96186	M10 x 25	2
4	Washer	96049	M10	2
5	Washer	96058	M12/13	20
6	Nyloc nut	96068	M10	2
7	Conveyor belt	10317		1
8	Nyloc nut	96222	M8	8
9	Hex screw	96165	M8 x 30	3
10	Connection rod for the belt	10136		2
11	Lock screw	96191	M8 x 25	3
12	Conveyor rubber flap	95130		1
13	Fastening rod for the rubber flap	61172		1
14	USIT	97213	1/2"	2
15	Double nipple	97203	3/8" x 1/2"	2
16	Double nipple	97208	3/4" x 1"	1
17	Washer	96061	M8/8.4	2
18	Upper roller of the conveyor	10132		1
19	Protective plate for the roller	10858		1
20	Upper roller guard	10868		1
21	Hex screw	96355	M12 x 280	2
22	Hex screw	96144	M12 x 20	2
23	Nut	96200	M12	10
24	Flange bolt	96172	M8 x 16	4
25	Pressure spring	95543	d4 x D22 x 100	2
26	Nyloc nut	96218	M12	4
27	Hydraulic motor	97334		1
28	Double nipple	97200	1/4" x 1/4"	1
29	USIT	97211	1/4"	1
30	Hex screw	96149	M12 x 45	2
31	Washer	96085	M8	2
32	Guard	47654		1

1.3 Upper section of the output conveyor, assembly

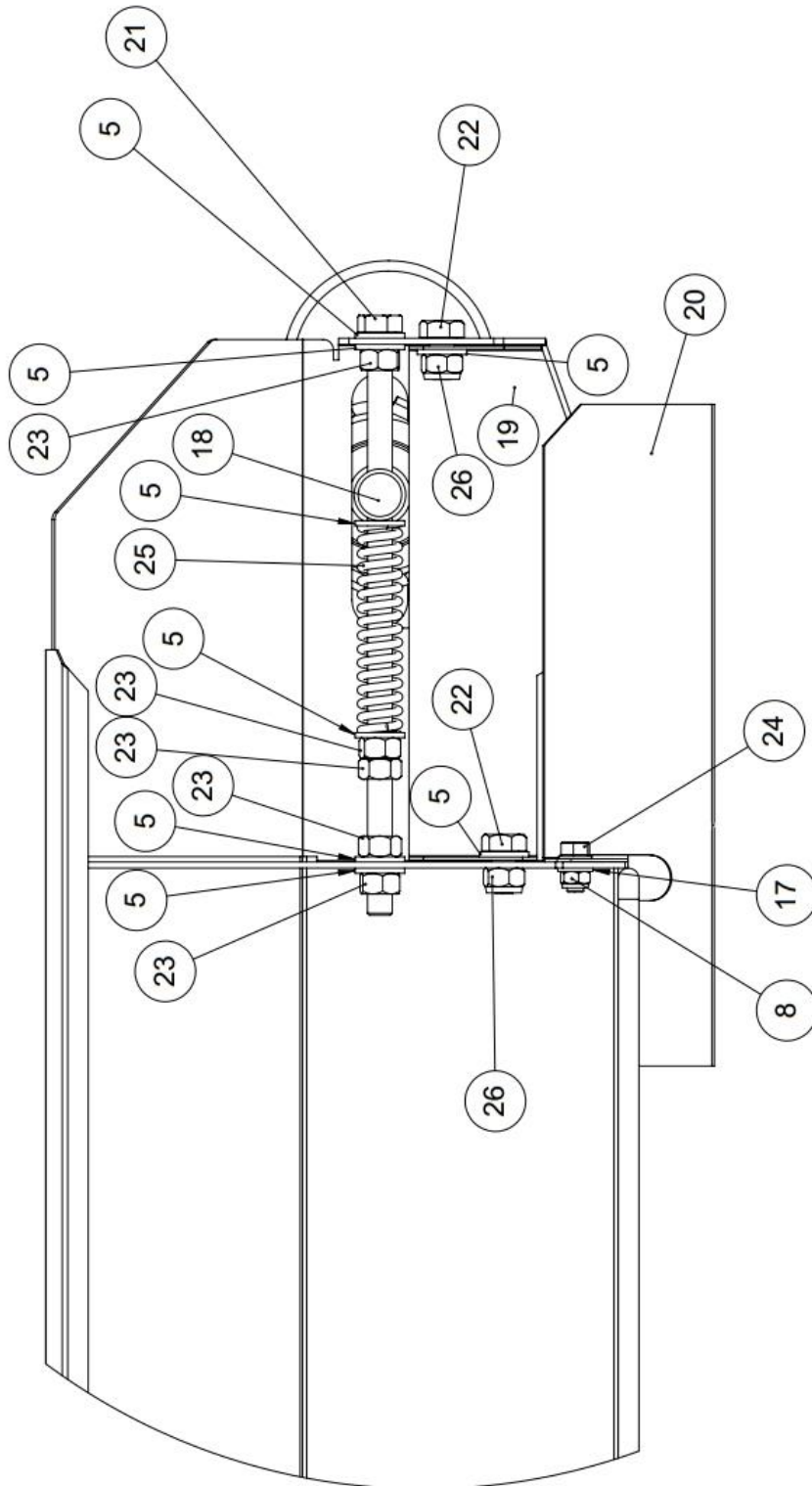

1.4 Upper section of the output conveyor, parts list

Number	Name	Part number	Dimensions	Pcs
5	Washer	96058	M12/13	20
8	Nyloc nut	96222	M8	8
9	Hex screw	96165	M8 x 30	3
17	Washer	96061	M8/8.4	2
18	Upper roller of the conveyor	10132		1
19	Protective plate for the roller	10858		1
20	Upper roller guard	10868		1
21	Hex screw	96355	M12 x 280	2
22	Hex screw	96144	M12 x 20	2
23	Nut	96200	M12	10
24	Flange bolt	96172	M8 x 16	4
25	Pressure spring	95543	d4 x D22 x 100	2
26	Nyloc nut	96218	M12	4

1.5 Output conveyor drive roller kit (50017863)

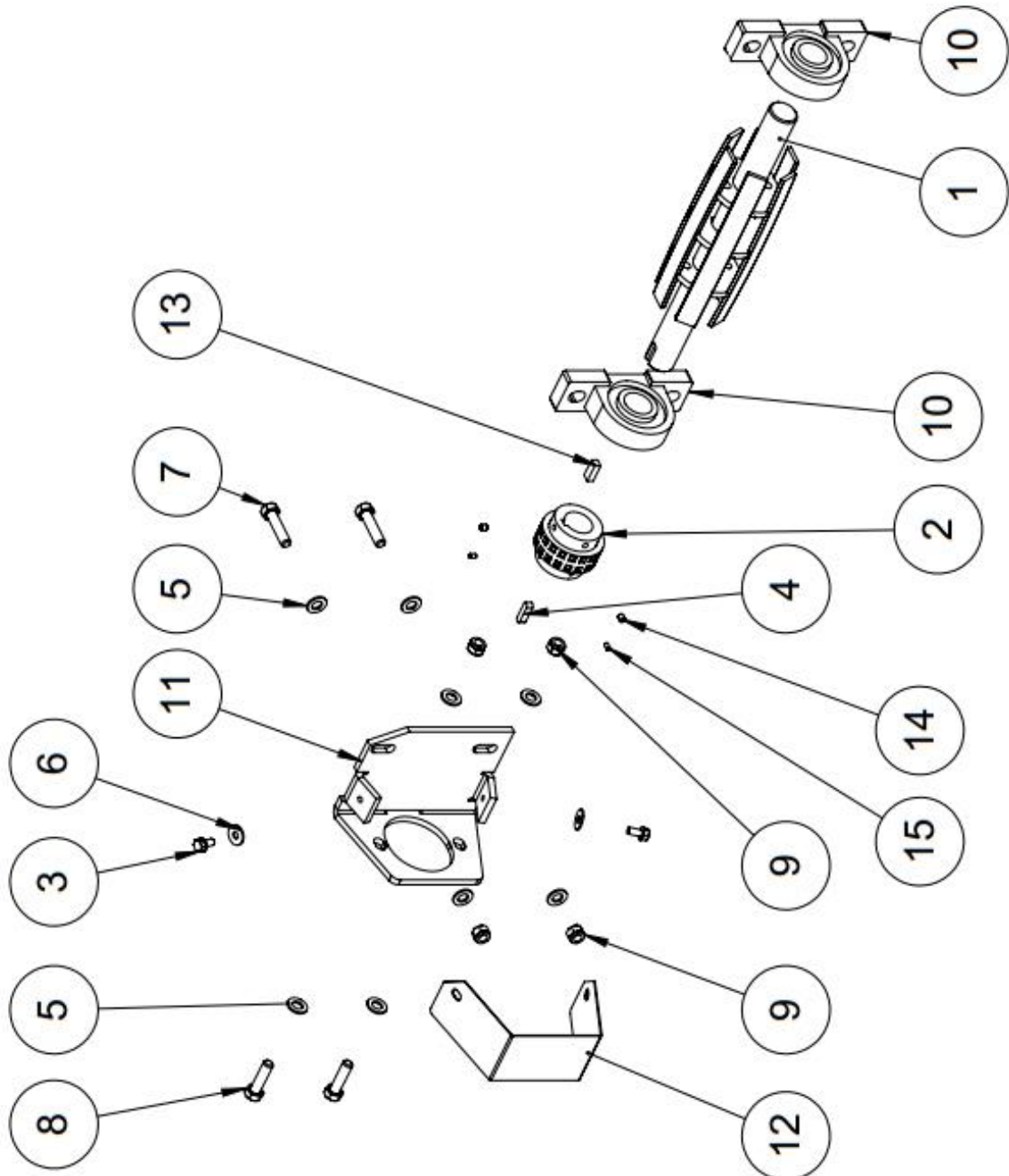

1.6 Output conveyor drive roller parts list (50017863)

Number	Name	Part number	Dimensions	Pcs
1	Lower section of the conveyor	50016890		1
2	Upper section of the conveyor	10126		1
3	Lock screw	96186	M10 x 25	2
4	Washer	96049	M10	2
5	Washer	96058	M12/13	20
6	Nyloc nut	96068	M10	2
7	Conveyor belt	10317		1
8	Nyloc nut	96222	M8	8
9	Hex screw	96165	M8 x 30	3
10	Connection rod for the belt	10136		2
11	Lock screw	96191	M8 x 25	3
12	Conveyor rubber flap	95130		1
13	Fastening rod for the rubber flap	61172		1
14	USIT	97213	1/2"	2
15	Double nipple	97203	3/8" x 1/2"	2
16	Double nipple	97208	3/4" x 1"	1
17	Washer	96061	M8/8.4	2
18	Upper roller of the conveyor	10132		1
19	Protective plate for the roller	10858		1
20	Upper roller guard	10868		1
21	Hex screw	96355	M12 x 280	2
22	Hex screw	96144	M12 x 20	2
23	Nut	96200	M12	10
24	Flange bolt	96172	M8 x 16	4
25	Pressure spring	95543	d4 x D22 x 100	2
26	Nyloc nut	96218	M12	4
27	Hydraulic motor	97334		1
28	Double nipple	97200	1/4" x 1/4"	1
29	USIT	97211	1/4"	1
30	Hex screw	96149	M12 x 45	2
31	Washer	96085	M8	2
32	Guard	47654		1

1.7 Output conveyor debris removal (50016903)

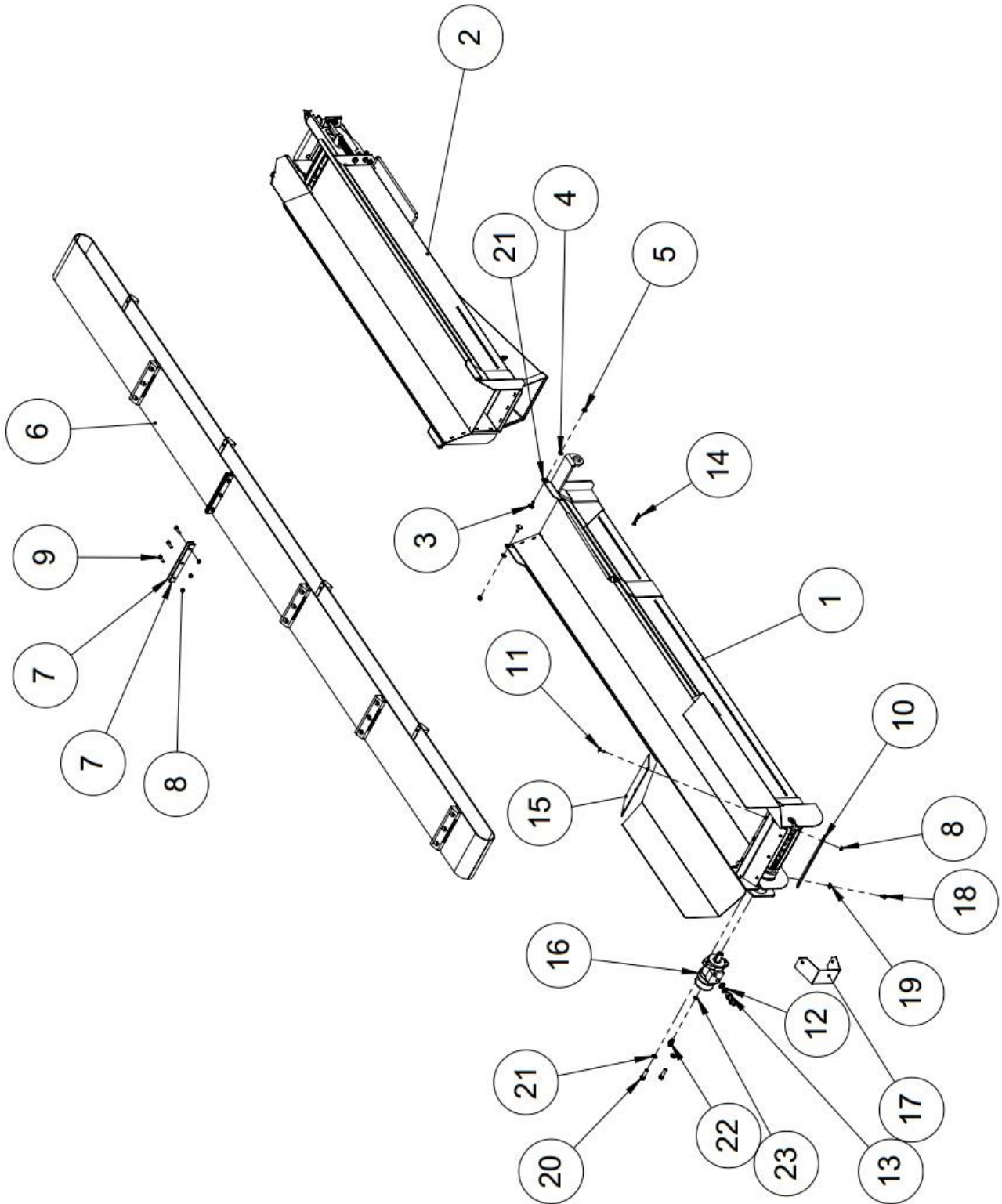

1.8 Output conveyor debris removal, parts list (50016903)

Number	Name	Part number	Dimensions	Pcs
1	Lower section of the conveyor	50016890		1
2	Upper section of the conveyor, debris removal	10831		1
3	Lock screw	96186	M10 x 25	2
4	Washer	96049	M10	2
5	Nyloc nut	96068	M10	2
6	Conveyor belt	10317		1
7	Connection rod for the belt	10136		2
8	Nyloc nut	96222	M8	8
9	Hex screw	96165	M8 x 30	3
10	Fastening rod for the rubber flap	61172		1
11	Lock screw	96191	M8 x 25	3
12	USIT	97213	1/2"	2
13	Double nipple	97203	3/8" x 1/2"	2
14	Hitch pin	96208		1
15	Conveyor rubber flap	95130	4 x 130 x 300	1
16	Hydraulic motor OMP50	97308		1
17	Guard	47654		1
18	Flange bolt	96172	M8 x 16	2
19	Washer	96085	M8	2
20	Hex screw	96107	M12 x 45	2
21	Washer	96058	M12	6
22	Double nipple	97200	1/4" x 1/4"	1
23	USIT	97211	1/4"	1
24	Locking nut	96218	M12	2

1.9 Output conveyor debris removal, upper section (10831)

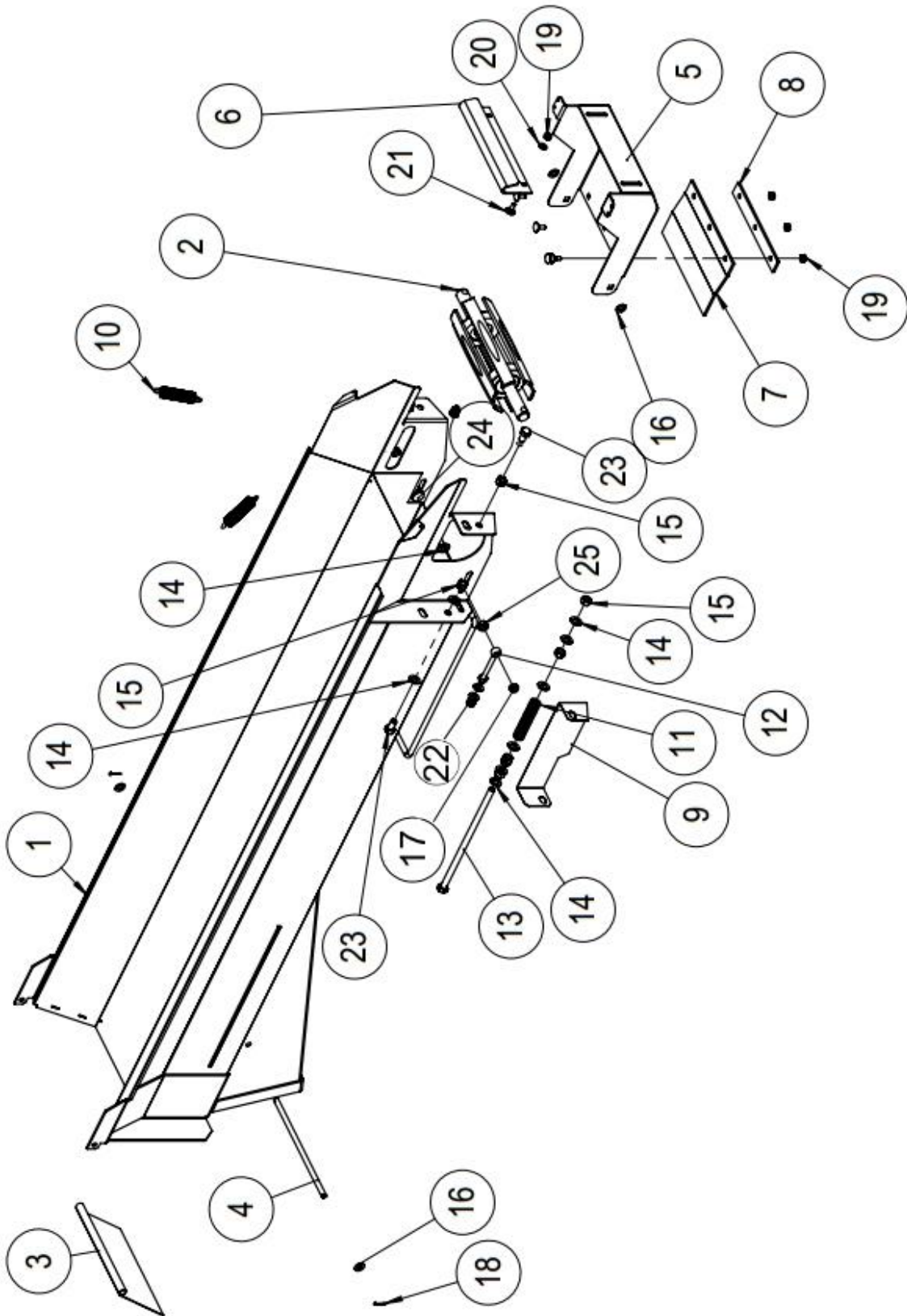

1.10 Output conveyor debris removal, upper section parts list (10831)

Number	Name	Part number	Dimensions	Pcs
1	Upper section of the conveyor, debris removal	10832		1
2	Upper roller of the conveyor	10132		1
3	Guard plate for the debris opening	37414		1
4	Hinge rod	37411		1
5	Debris separator	10834		1
6	Lip plate	37412		1
7	Debris separator rubber	10864		1
8	Connection rod for the belt	10136		1
9	Protective plate for the roller	10858		1
10	Draw spring	95390	2 x 20 x 100	2
11	Pressure spring	95543	d4 x D22 x 100	2
12	Screw hoop	96338	M10 x 90	2
13	Hex screw	96355	M12 x 280	2
14	Washer	96058	M12/13	17
15	Nut	96200	M12	12
16	Washer	96049	M10	8
17	Nyloc nut	96068	M10	2
18	Cotter pin	96244	2.5 x 20	2
19	Nyloc nut	96222	M8	5
20	Washer	96061	M8/8.4	2
21	Lock screw	96187	M8 x 20	5
22	Nut	96199	M10	6
23	Hex screw	96144	M12 x 20	2
24	Lock screw	96312	M10 x 50	2
25	Nyloc nut	96218	M12	1

1.11 Output conveyor swivel cylinder, parts list (11160)

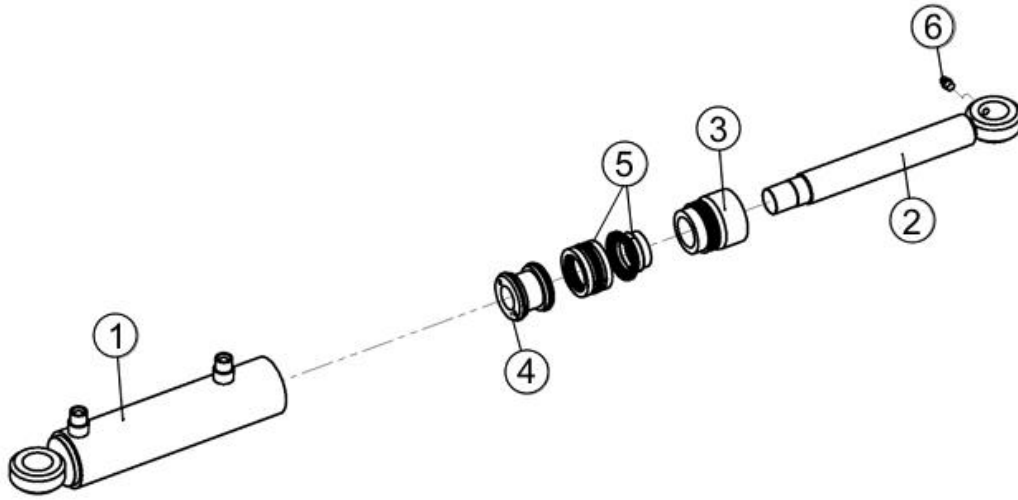

1.12 Output conveyor swivel cylinder, parts list (11160)

Number	Name	Part number	Dimensions	Pcs
1	Pipe assembly	11161		1
2	Arm assembly	11162		1
3	Arm control	10261		1
4	Cylinder piston	10260		1
5	Seal kit	97294	D50/32	1
6	Lubrication nipple	96276	M8 x 1	1

1.13 Splitting blade lift cylinder (60915)

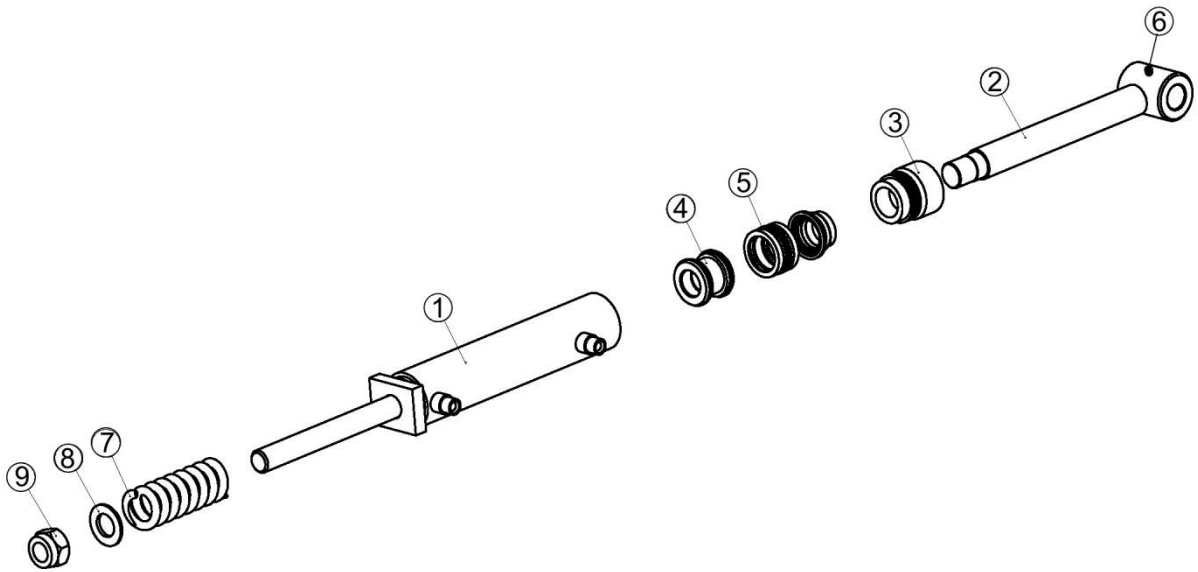

1.14 Splitting blade lift cylinder (60915)

Number	Name	Part number	Dimensions	Pcs
1	Pipe assembly	60916		1
2	Arm assembly	60920		1
3	Arm control	10261		1
4	Cylinder piston	10260		1
5	Seal kit	97294	D50/32	1
6	Lubrication nipple	96276	M8 x 1	1
7	Pressure spring	95026	26 x 9 x 120	1
8	Washer	96054	M25	1
9	Nyloc nut	96214	M24	1

1.15 Cutting blade cylinder (61095)

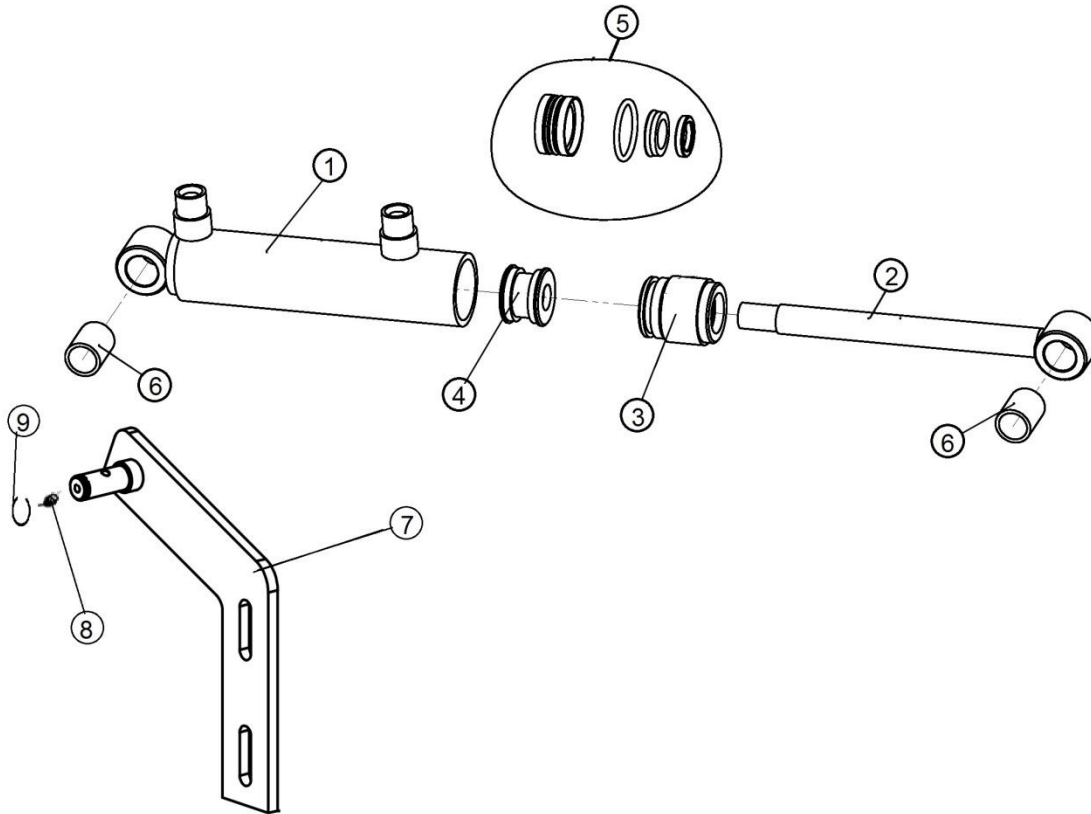

1.16 Cutting blade cylinder parts list (61095)

Number	Name	Part number	Dimensions	Pcs
1	Pipe assembly	47747		1
2	Arm assembly	47382		1
3	Arm control	10269	32 / 16	1
4	Cylinder piston	10270	32 / 16	1
5	Seal kit	97293	D32/16	1
6	Slide bearing BRM 10 TFP	95062		2
7	Cylinder mount	61094		1
8	Lubrication nipple	96273	M6 x 1	1
9	Retaining ring	96038	16 x 1	

1.17 Splitting cylinders (61112 + 61116)

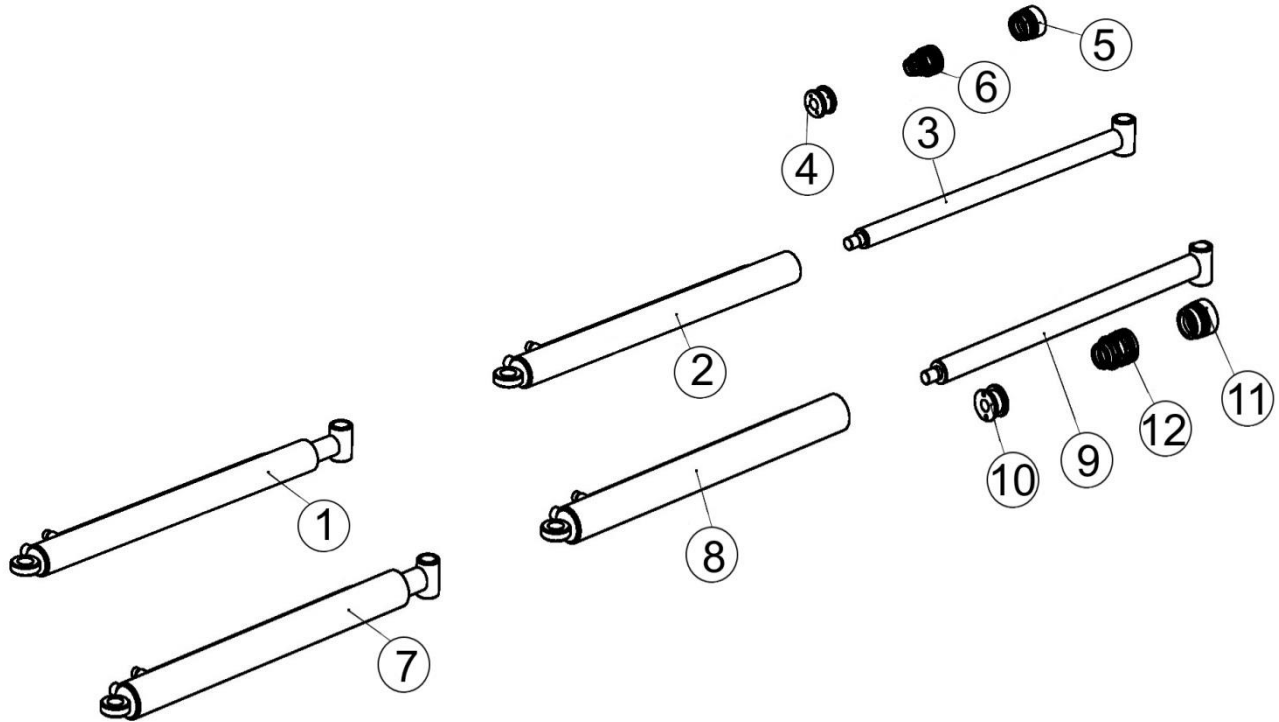

1.18 Splitting cylinders parts list (61112 + 61116)

Number	Name	Part number	Dimensions	Pcs
1	Cylinder (upper)	61112		1
2	Pipe assembly	61114		1
3	Arm assembly	61113		1
4	Cylinder piston	10664		1
5	Arm control	10665		1
6	Seal kit	97296	D63/45	1
7	Cylinder (lower)	61116		1
8	Pipe assembly	61117		1
9	Arm assembly	61118		1
10	Cylinder piston	37028 m		1
11	Arm control	60597		1
12	Seal kit	97368	D70/50	1

1.19 Slide pack (61502)

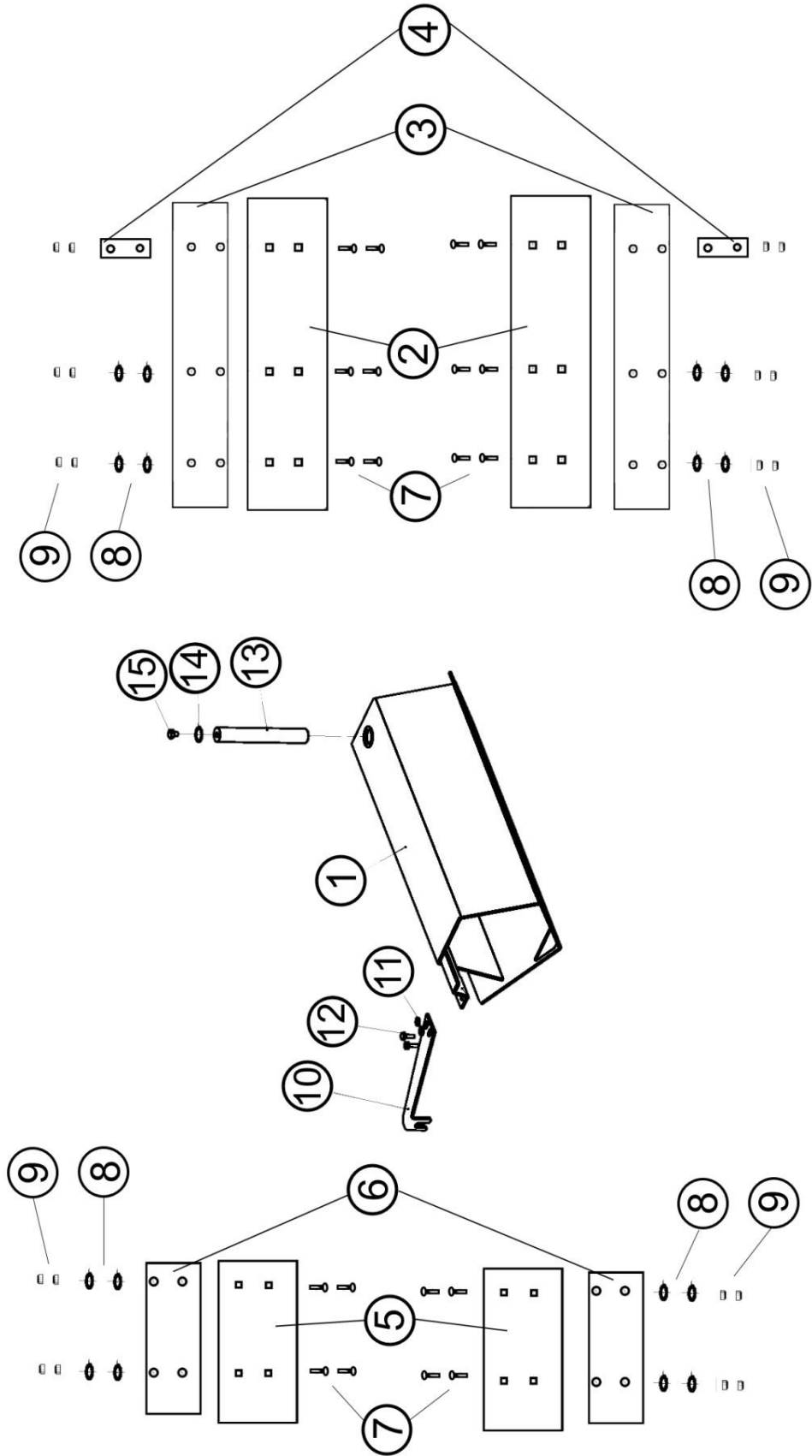

1.20 Slide pack parts list (61502)

Number	Name	Part number	Dimensions	Pcs
1	Slide	61070		1
2	Slide support plate	61047		2
3	Slide support plate addition	61048		2
4	Stiffener plate	61196		2
5	Slide support plate	61046		2
6	Slide support plate addition	61049		2
7	Lock screw	96189	M12 x 40	20
8	Washer	96306	M12	16
9	Nyloc nut	96218	M12	20
10	Valve guide plate (08/2015->)	50021333		1
10	Valve guide plate (->08/2015)	61069		1
11	Washer	96049	M10	2
12	Hex screw	96066	M10 x 20	2
13	Slide fastening pin	61084	D35 – 235	1
14	Lock ring	96240	35 x 1.5	1
15	Hex screw	96144	M12 x 20	1

1.21 Frame

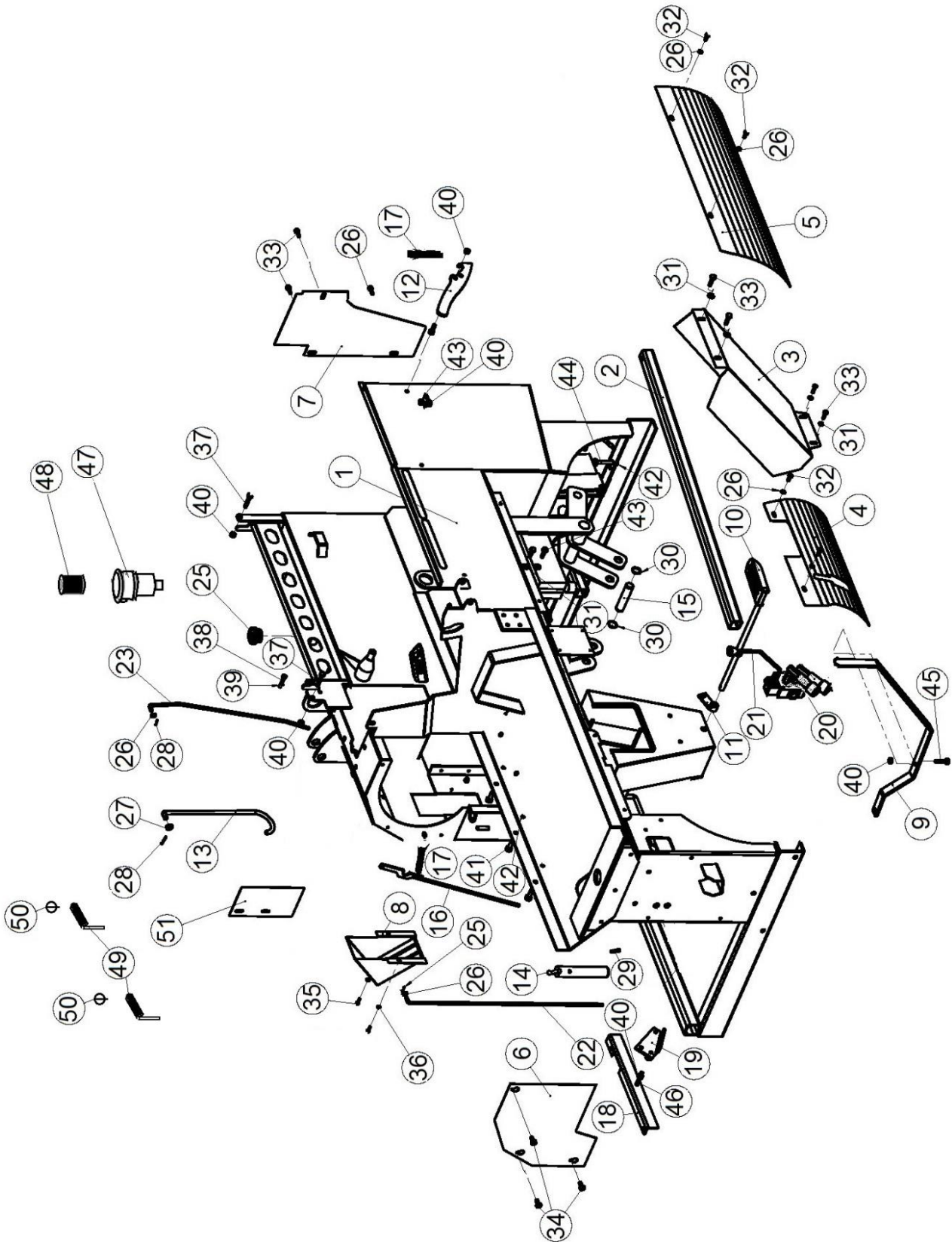

1.22 Frame parts list

Number	Name	Part number	Dimensions	Pcs
1	Frame + oil tank	61010 + 61090		1 + 1
2	Conveyor pipe	60933	40 x 40 x 1,155	1
3	Hose guard	61025		1
4	Front cover, left	61088		1
5	Front cover, right	61087		1
6	Protective cover	60136		1
7	Protective cover for the tank	60208		1
8	Sawdust guide	10150		1
9	Return lever	61190		1
10	Foot pedal	60350		1
11	Pedal rod	60320		1
12	Output conveyor locking latch	47089		1
13	Cardan shaft hook	08055		1
14	Cylinder pin	61078	D35 x 182	1
15	Splitting blade adjustment pin	47052	D25 x 130	1
16	Vertical bar	61185		1
17	Draw spring	95390	2 x 20 x 100	2
18	Idler	60363		1
19	Jointed lever	60367		1
20	Log lifter accessory valve	60813		1
21	Operating rod for the accessory valve	61119		1
22	Front cage locking bar	60375		1
23	Rear cage locking bar	60373		1
24	Oil cap	97429		1
25	Retaining ring	96038	16 x 1	1
26	Washer	96057	M8	9
27	Washer	96050	M12	1
28	Hitch pin	96208		2
29	Spring pin	96079	8 x 60	1
30	Retaining ring	96042	25 x 1.2	2
31	Washer	96048	M10	4
32	Hex screw	96162	M8 x 20	2
33	Hex screw	96163	M8 x 25	6
34	Hex screw	96138	M10 x 20	3
35	Hex screw	96135	M6 x 20	2
36	Washer	96056	M6	2
37	Hex screw	96099	M10 x 50	2
38	Hex screw	96092	M8 x 40	1
39	Nut	96205	M8	1
40	Nyloc nut	96067	M10	6
41	Hex screw	96145	M12 x 30	3
42	Nut	96200	M12	4
43	Hex screw	96140	M10 x 30	3
44	Hex screw	96110	M12 x 70	2
45	Lock screw	96314	M10 x 40	1
46	Hex screw	96280	M10 x 70	1
47	Filter box + insert	97349		1
48	Filter insert	97348		1
49	Pin	36033	D=28 x 110	1
50	Cotter pin	96245	3.2 x 20	2
51	Cardan shaft guard, left	60698		1

1.23 Log rack (60180)

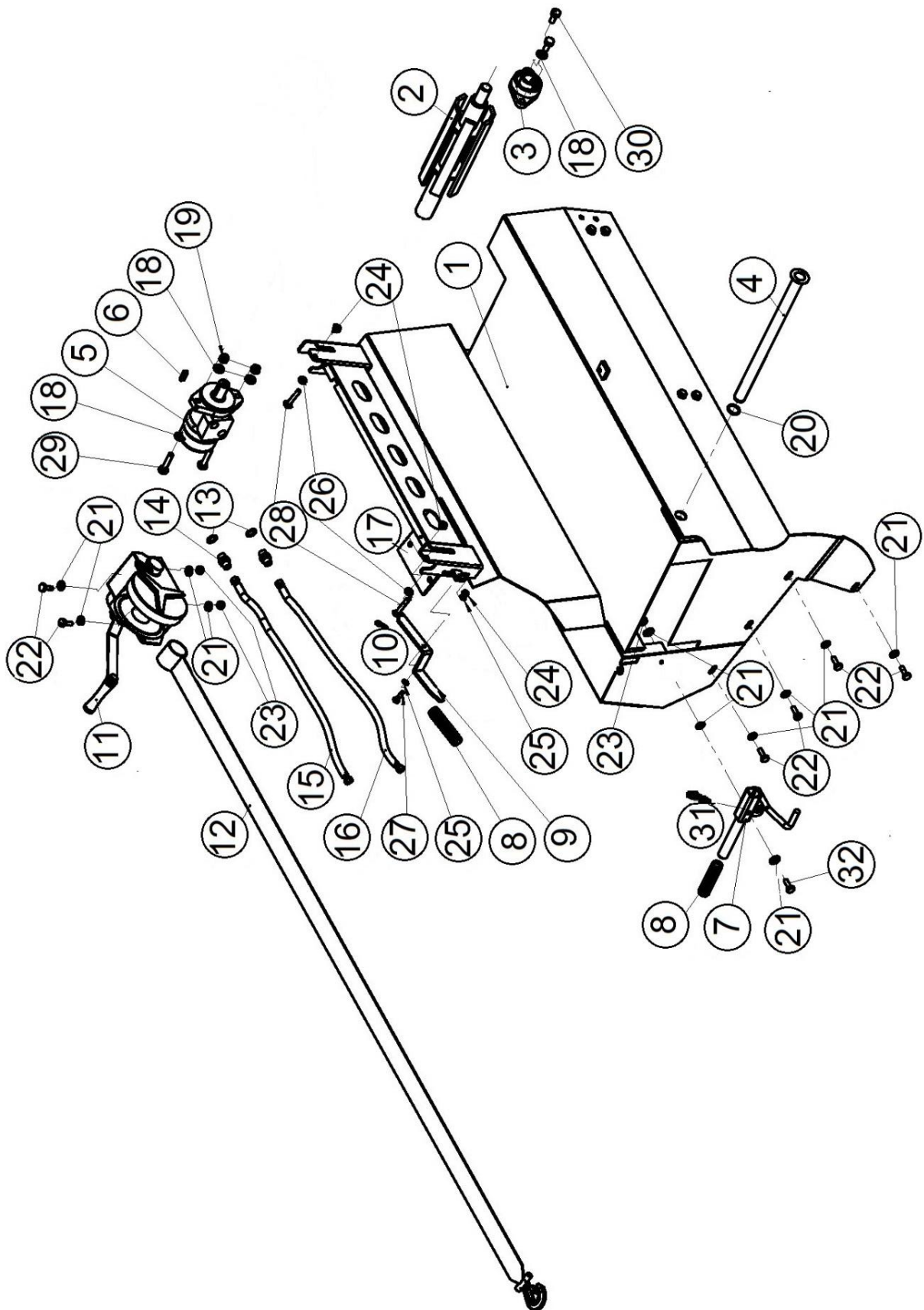

1.24 Log rack parts list (60180)

Number	Name	Part number	Dimensions	Pcs
1	Log rack	60180		1
2	Log rack drive roller	50001404		1
3	Bearing UCFL 205	95057		1
4	Input conveyor mounting shaft	60196	D25 – 425	1
5	Hydraulic motor 160	97307		1
6	Wedge for hydraulic motor	97371		1
7	Input conveyor locking handle	61108		1
8	Handle	95034	D22 x 120	2
9	Front cage locking handle	10341		1
10	Draw spring	95391	0.9 x 9.8 x 40	1
11	Winch + crank	95069		1
12	Winch strap	95068	3 m	1
13	USIT	97213		2
14	Double nipple	97		2
15	Hydraulic hose straight/straight	97		1
16	Hydraulic hose straight/straight	97		1
17	Winch fastening plate	60610		1
18	Washer	96050	M12	4
19	Nyloc nut	96218	M12	2
20	Retaining ring	96042	25 x 1.2	1
21	Washer	96049	M10	11
22	Hex screw	96139	M10 x 25	6
23	Nyloc nut	96067	M10	2
24	Nyloc nut	96222	M8	3
25	Washer	96057	M8	2
26	Nut	96196	M8	2
27	Hex screw	96164	M8 x 25	1
28	Hex screw	96165	M8 x 30	2
29	Hex screw	96148	M12 x 40	2
30	Hex screw	96144	M12 x 20	2
31	Draw spring	95423	2 x 15 x 75	1
32	Hex screw	96101	M10 x 65	1

1.25 Log rack extension (60950)

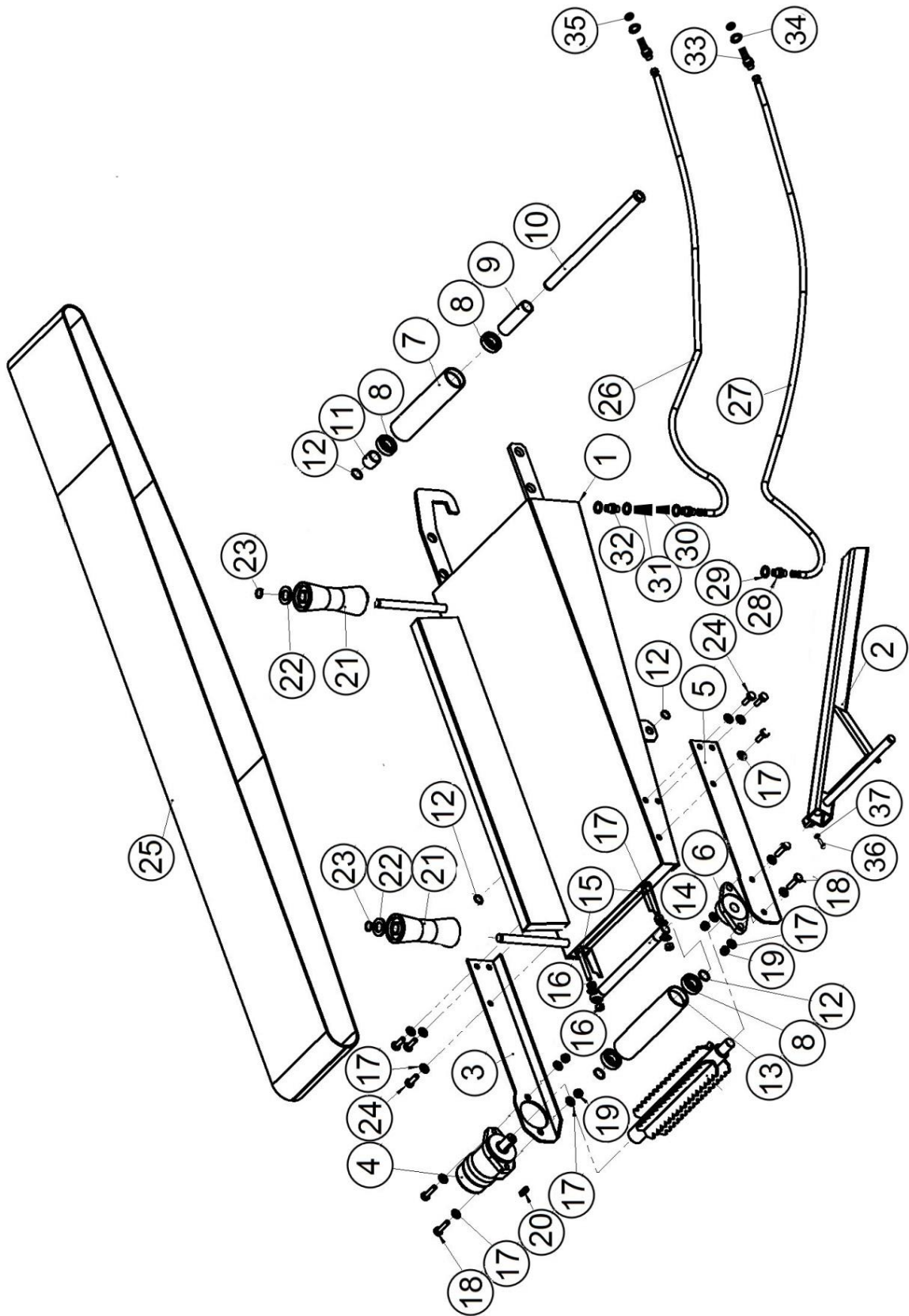

1.26 Log rack extension parts list (60950)

Number	Name	Part number	Dimensions	Pcs
1	Extension	60950		1
2	Extension support	60300		1
3	Fastening plate	47184		1
4	Hydraulic motor MP160	97307		1
5	Drive roller fastening	47217_painted		1
6	Bearing UCFL 205	95057		1
7	Spacer	60286a		1
8	Groove ball bearing 6205 2rs FK	95050		4
9	Spacer bushing	60297		1
10	Spacer shaft	60296		1
11	Spacer bushing	60298		1
12	Retaining ring	96042	25 x 1.2	5
13	Tensioning roller	60286		1
14	Tensioning roller shaft	60294	D25 x 330	1
15	Hex screw	96142	M12 x 120	2
16	Nut	96200	M12	6
17	Washer	96058	M12/13	22
18	Hex screw	96148	M12 x 40	4
19	Nyloc nut	96218	M12	4
20	Wedge for hydraulic motor	97371		1
21	Keel roller	95001	185 mm	2
22	Washer	96053	M20	2
23	Retaining ring	96040	20 x 1.2	2
24	Hex screw	96144	M12 x 20	6
25	Input conveyor belt	95298		1
26	Hydraulic hose straight/90	97095	2200 x 3/8	1
27	Hydraulic hose 90/90	97094	2200 x 3/8	1
28	Double nipple	97203	3/8 x 1/2	2
29	USIT	97213	1/2	4
30	Quick coupler, male	97209	1/2	1
31	Quick coupler, female	97210	1/2	1
32	Double nipple	97204	1/2 x 1/2	1
33	Long nipple	97278	3/8	2
34	Jam nut	97279		2
35	Washer	96052	M16	2
36	Hex screw	96140	M10 x 30	1
37	Nut	96199	M10	1

1.27 Lever stand (60835)

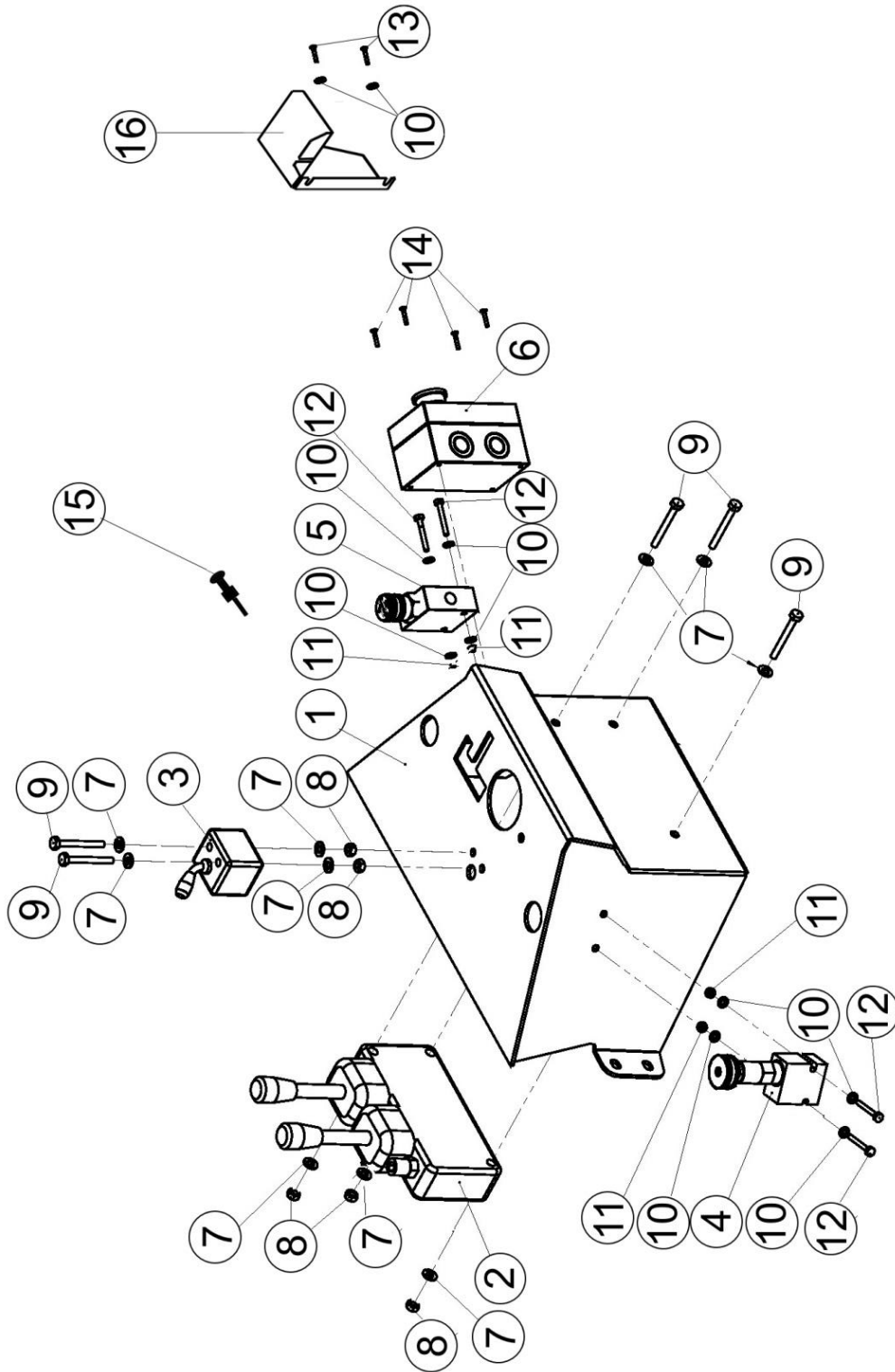

1.28 Viputelineen osaluettelo (60835)

Number	Name	Part number	Dimensions	Pcs
1	Lever stand	60830		1
2	Hydraulic valve	10591		1
3	3-way valve kit	60840		1
4	Pressure relief kit	60841		1
5	Flow control valve kit	60842		1
6	Remote starter kit	61219		1
7	Washer	96061	M8	10
8	Nyloc nut	96216	M8	5
9	Hex screw	96127	M8 x 65	3
10	Washer	96084	M6	10
11	Nyloc nut	96221	M6	4
12	Hex screw	96119	M6 x 50	4
13	Hex socket screw	96000	M6 x 12	2
14	Slot head screw	96284	M4 x 16	4
15	Cooler switch	61360		1
16	Remote starter guard	60838		1
17	Hex screw	96124	M8 x 50	2

1.29 Valve mechanism (61130)

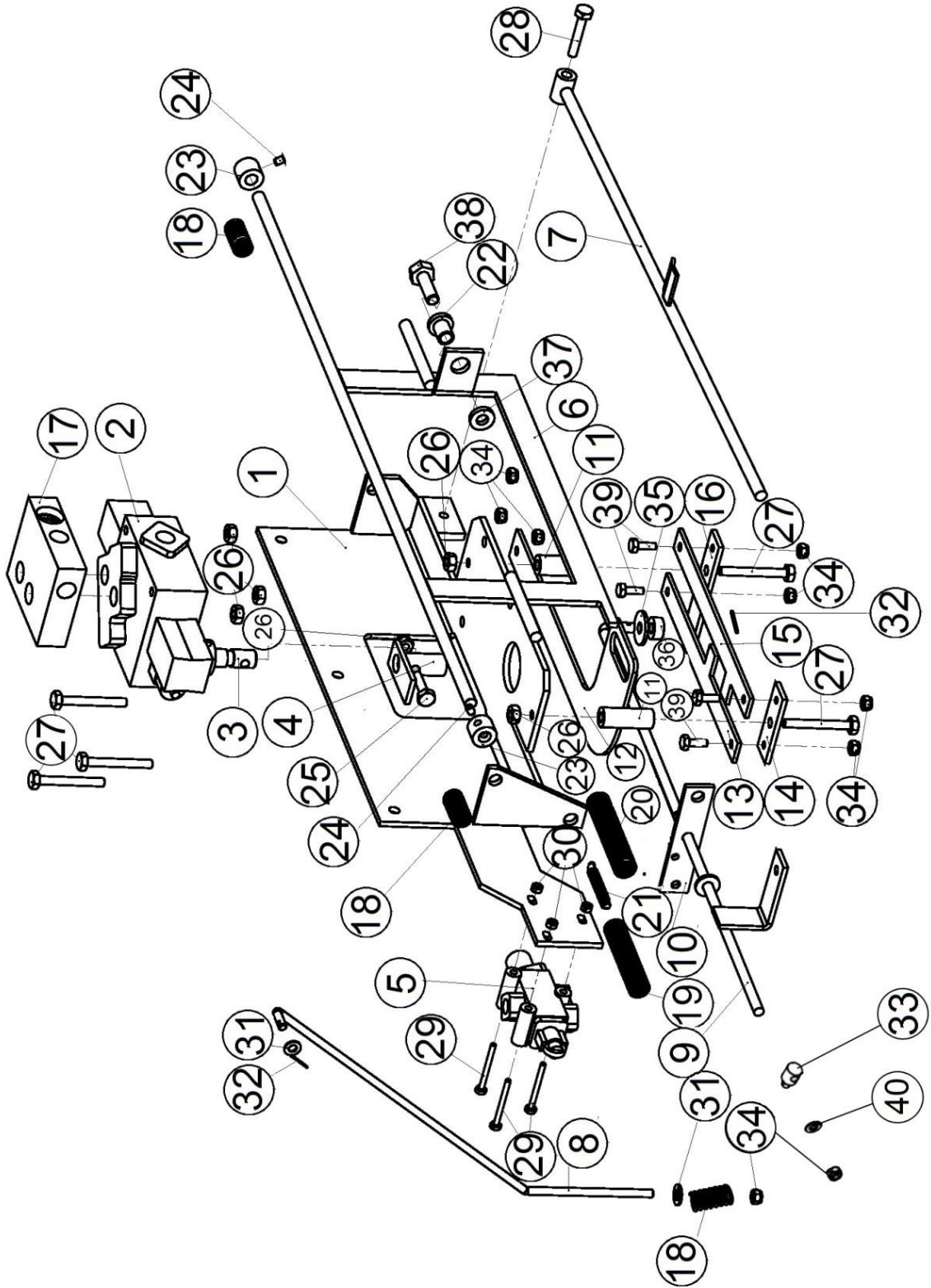

1.30 Valve mechanism parts list (61130)

Number	Name	Part number	Dimensions	Pcs
1	Valve fastening plate	61125		1
2	Splitting valve	97507		1
3	Valve ball joint	97359		1
4	Operating lever	61127		1
5	Cage valve assembly	61350		1
6	Valve releasing plate	50021364		1
7	Horizontal bar / Trigger lever	61138		1
8	Foot pedal lever	61121		1
9	Connecting rod assembly	60758		1
10	Foot pedal plate	60744		1
11	Return mechanism bushing	60783		2
12	Releasing plate	61139		1
13	Stopper plate	60784		1
14	Return mechanism joint plate	60782		1
15	Stopper plate	60781		1
16	Return mechanism joint plate	60785		1
17	Automatic speed valve	60812		1
18	Pressure spring	95008	3.5 x 22 x 38	3
19	Pressure spring	95022	22 x 2.5 – 140	1
20	Pressure spring	95018	22 x 2 – 140	1
21	Draw spring	95016	2 x 20 x 100	1
22	Valve bushing	61146		1
23	Valve drive bushing	10170	D25/12.5 – 20	2
24	Clamping screw	96228	M8 x 8	2
25	Hex screw	96140	M10 x 30	1
26	Nut, low profile	96359	M10	2
27	Hex screw	96280	M10 x 70	2
28	Hex screw	96099	M10 x 50	1
29	Hex screw	96127	M8 x 65	3
30	Washer	96061	M8	6
31	Washer	96082	M8	2
32	Cotter pin	96245	3.2 x 20	2
33	Joint nipple	60328		1
34	Nyloc nut	96222	M8	7
35	Washer	96064	M10	1
36	Joint plate bushing	60786		1
37	Valve washer	61147	D25/12 – 5	1
38	Hex screw	96309	12 x 1.0 x 40	1
39	Hex screw	96161	M8 x 20	4
40	Washer	96049	M10	1

1.31 Output conveyor swivel device

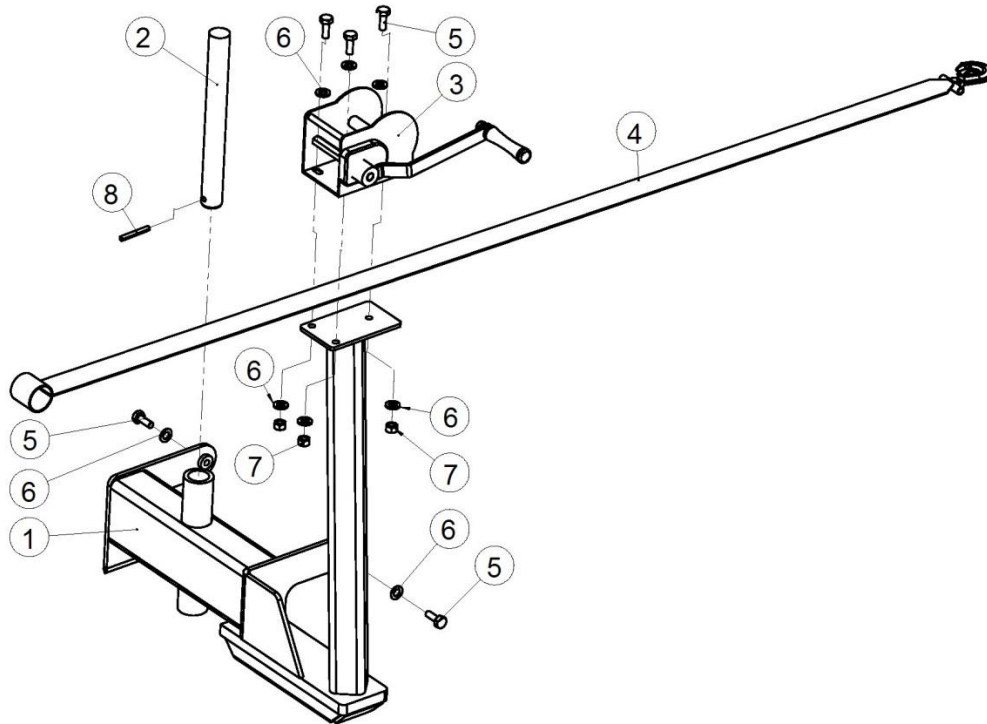

1.32 Output conveyor swivel device parts list

Number	Name	Part number	Dimensions	Pcs
1	Output conveyor swivel device	60600		1
2	Swivel device fastening pin	60613	D35 x 330	1
3	Winch Goliath 8AFS	95412		1
4	Winch strap	95068	3 m	1
5	Hex screw	96145	M12 x 30	5
6	Washer	96050	M12	8
7	Nyloc nut	96218	M12	3
8	Spring pin	96079	8 x 60	1

1.33 Automatic speed valve(60812)

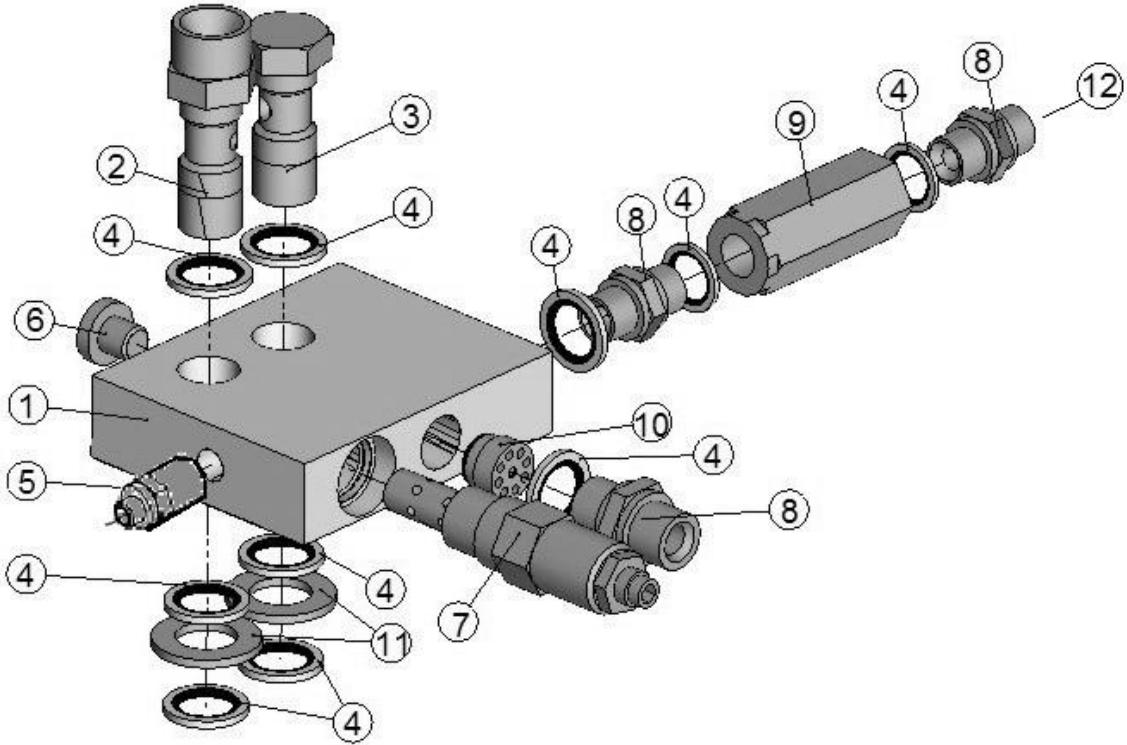

1.34 Automatic speed valve parts list(60812)

Number	Name	Part number	Dimensions	Pcs
1	Speed valve frame	47496		1
2	Banjo bolt	47497		1
3	Banjo bolt	47499		1
4	USIT	97213	1/2"	10
5	Pressure measuring nipple	97378	1/4"	1
6	Plug	97260	3/8"	1
7	Adjustment cartridge PS-10	97412		1
8	Double nipple	97204	1/2" x 1/2"	3
9	Check valve	97252	1/2"	1
10	Internal check valve VRR 03	97437		1
11	Washer	96053	M20	2
12	Hydraulic hose straight int./int.	97099	650 x 1/2"	1

1.35 Blade drive end (61247)

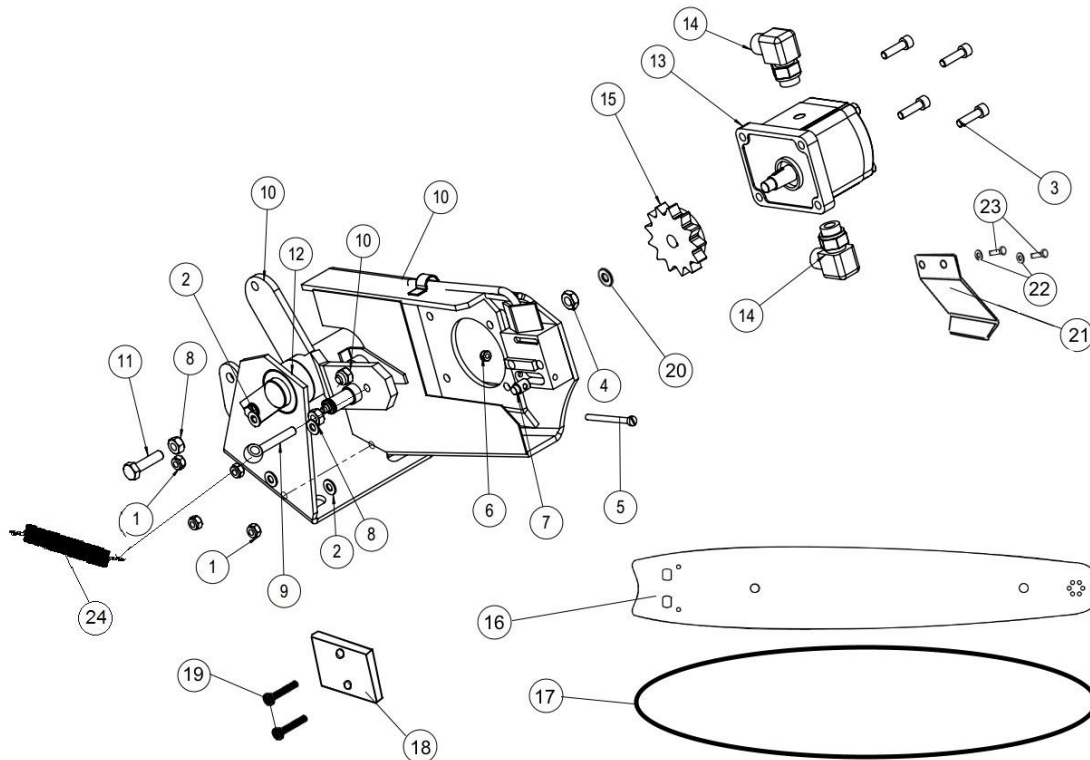

1.36 Blade drive end parts list (61247)

Number	Name	Part number	Dimensions	Pcs
1	Nyloc nut	96222	M8	4
2	Washer	96061	M8	4
3	Hex socket screw	96341	M8 x 30	4
4	Nut	96200	M12	1
5	Slot head screw	96267	M6 x 70	1
6	Nyloc nut	96221	M6	1
7	Bar tightening	47295		1
8	Nut	96199	M10	2
9	Screw hoop	96338	10 x 90	1
10	Drive end component assembly	50005773		1
11	Hex screw	96098	M10 x 40	1
12	Nyloc nut	96068	M10	1
13	Gear motor	97589	20.8	1
14	Directional elbow nipple	97247	1/2	2
15	Chain drive wheel	50004550	404 / 13 teeth	1
16	Saw bar	95137	20" 1.6mm	1
17	Cutting chain	95138	71 loops 1.6 mm	1
18	Fastening rod for the saw bar	47294		1
19	Hex screw	96307	M8 x 55	2
20	Washer	96050	M12	1
21	Lever drive plate	61324		1
22	Washer	96049	M10	2
23	Hex screw	96139	M10 x 25	2
24	Draw spring	95403	3.5 x 30 x 180	1

1.37 Blade drive end (50005773)

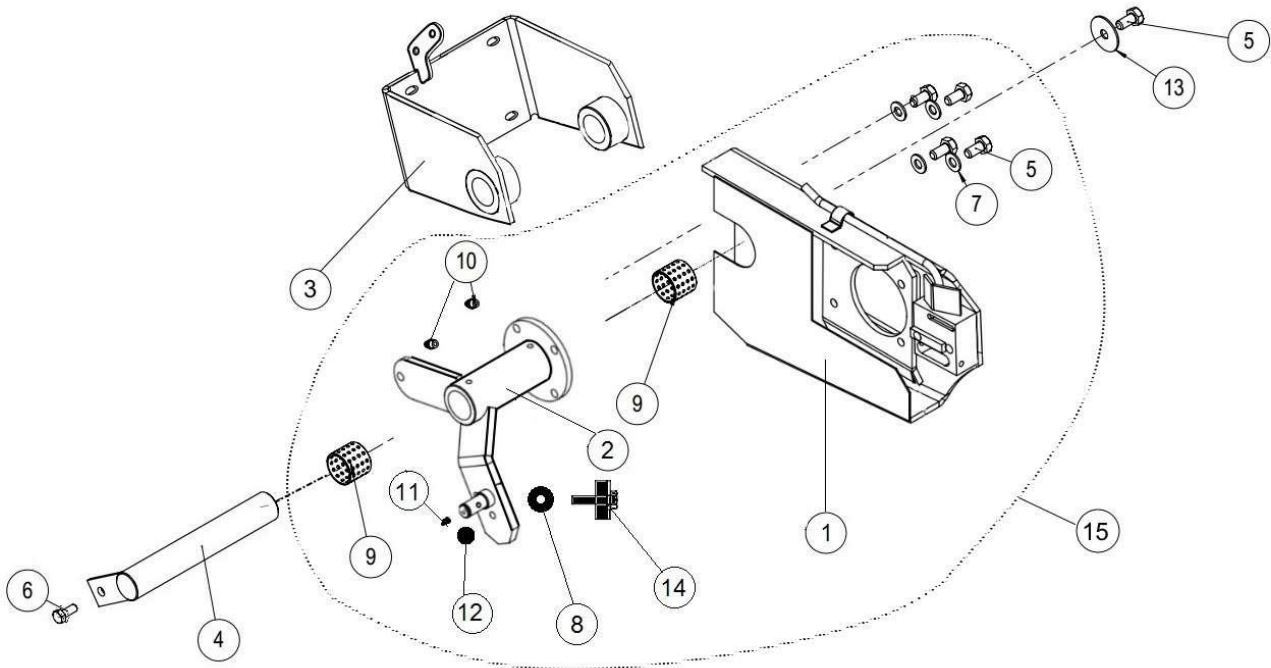

1.38 Blade drive end parts list (50005773)

Number	Name	Part number	Dimensions	Pcs
1	Blade drive end	61246		1
2	Drive plates	61342		1
3	Drive end bracket	61239		1
4	Blade drive shaft	47244		1
5	Hex screw	96138	M10 x 20	5
6	Flange bolt	96172	M8 x 16	1
7	Washer	96049	M10	4
8	Trigger bushing	10464		1
9	Slide bearing	95276	32 x 36 x 30	2
10	Lubrication nipple	96276	M8 x 1	2
11	Lubrication nipple	96273	M6 x 1	1
12	Nyloc nut	96068	M10	1
13	Washer	10492	D40/11	1
14	Adjustment rod fastening	61097		1
15	Blade drive assembly	61259		1

1.39 Cutting assembly

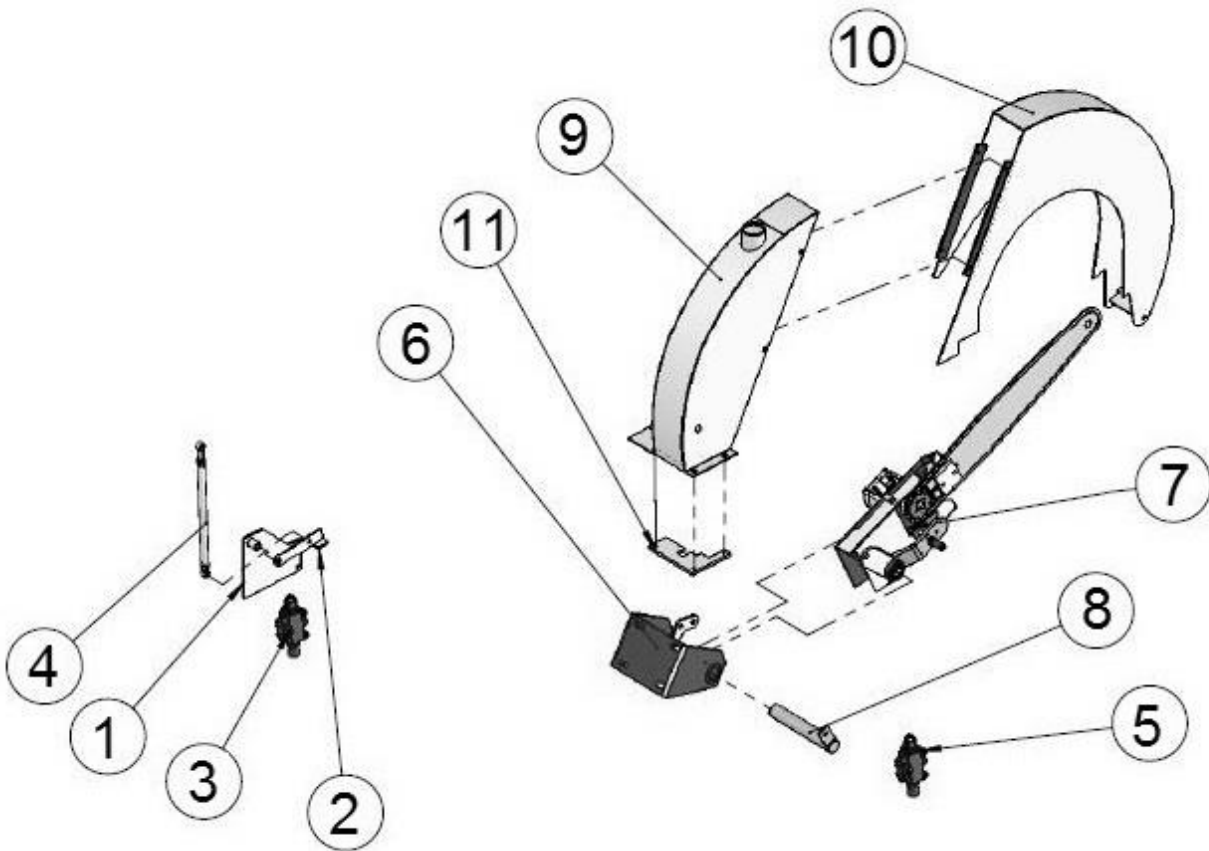

1.40 Cutting assembly parts list

Number	Name	Part number	Dimensions	Pcs
1	Oil tank fastener			1
2	Valve press	61250		1
3	Saw valve	61351		1
4	Adjustment rod	61238		1
5	Cage valve	61350		1
6	Drive end bracket	61239		1
7	Blade drive end	61247		1
8	Blade drive shaft	47244		1
9	Cutting chain oil tank	61248		1
10	Blade guard	61243		1
11	Drive end stop plate	61223		

1.41 Angle gear + pump, TR model (61253)

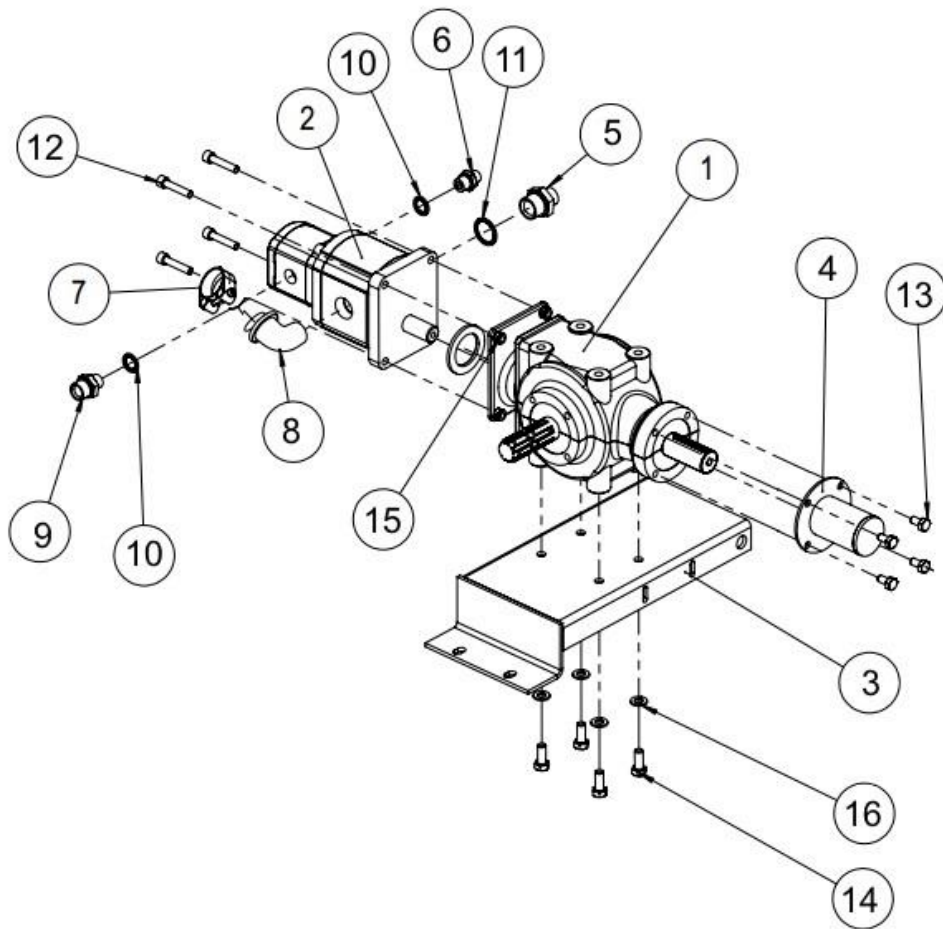

1.42 Angle gear + pump, TR model parts list (61253)

Number	Name	Part number	Dimensions	Pcs
1	Angle gear 2061	95173		1
2	Hydraulic pump	97326		1
3	Angle gear bed	61252		1
4	Angle gear top	47607		1
5	Double nipple	97208	3/4" / 1"	1
6	Double nipple	97203	3/8" / 1/2"	1
7	Steel hose clamp	97850	43 mm	1
8	Suction connector	95849	1" / 32 mm	1
9	Double nipple	97205	1/2" / 3/4"	1
10	USIT	97213	1/2"	2
11	USIT	97215	1"	1
12	Hex socket screw	96011	M10 x 50	4
13	Hex screw	96138	M10 x 20	4
14	Hex screw	96146	M12 x 30	4
15	Nyloc nut	96067	M10	4
16	Sesco washer	96253	M12	4

1.43 Angle gear + pump, Combi model (61313)

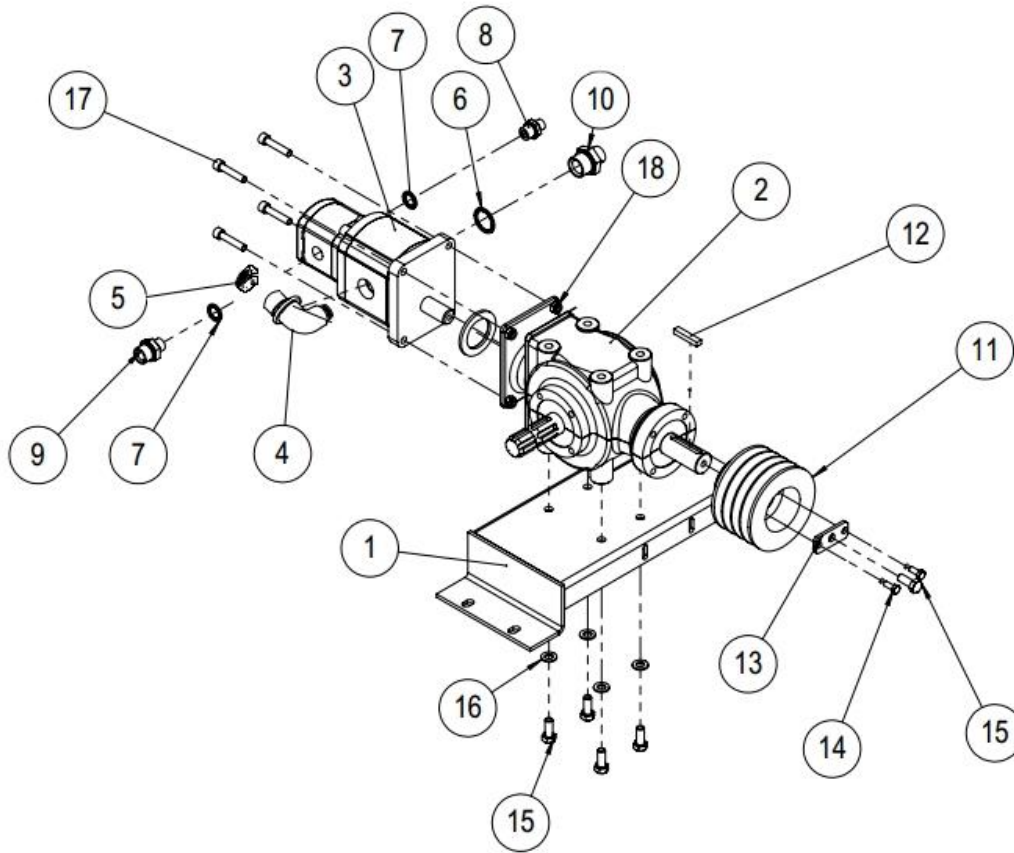

1.44 Angle gear + pump, Combi model parts list (61313)

Number	Name	Part number	Dimensions	Pcs
1	Angle gear bed	61252		1
2	Angle gear 2061	95173		1
3	Hydraulic pump	97326		1
4	Suction connector	95849	1" / 32 mm	1
5	Steel hose clamp	97850	43 mm	1
6	USIT	97215	1"	1
7	USIT	97213	1/2"	2
8	Double nipple	97203	3/8" / 1/2"	1
9	Double nipple	97205	1/2" / 3/4"	1
10	Double nipple	97208	3/4" / 1"	1
11	Belt pulley B4132	95123		1
12	Wedge	47837	10 x 8 x 50	1
13	Fastening plate for the belt pulley	47604		1
14	Hex screw	96130	M8 x 20	2
15	Hex screw	96146	M12 x 30	5
16	Washer	96058	M12/13	4
17	Hex socket screw	96011	M10 x 50	4
18	Nyloc nut	96068	M10	4

1.45 Electric motor + extension shaft, Combi model (61316)

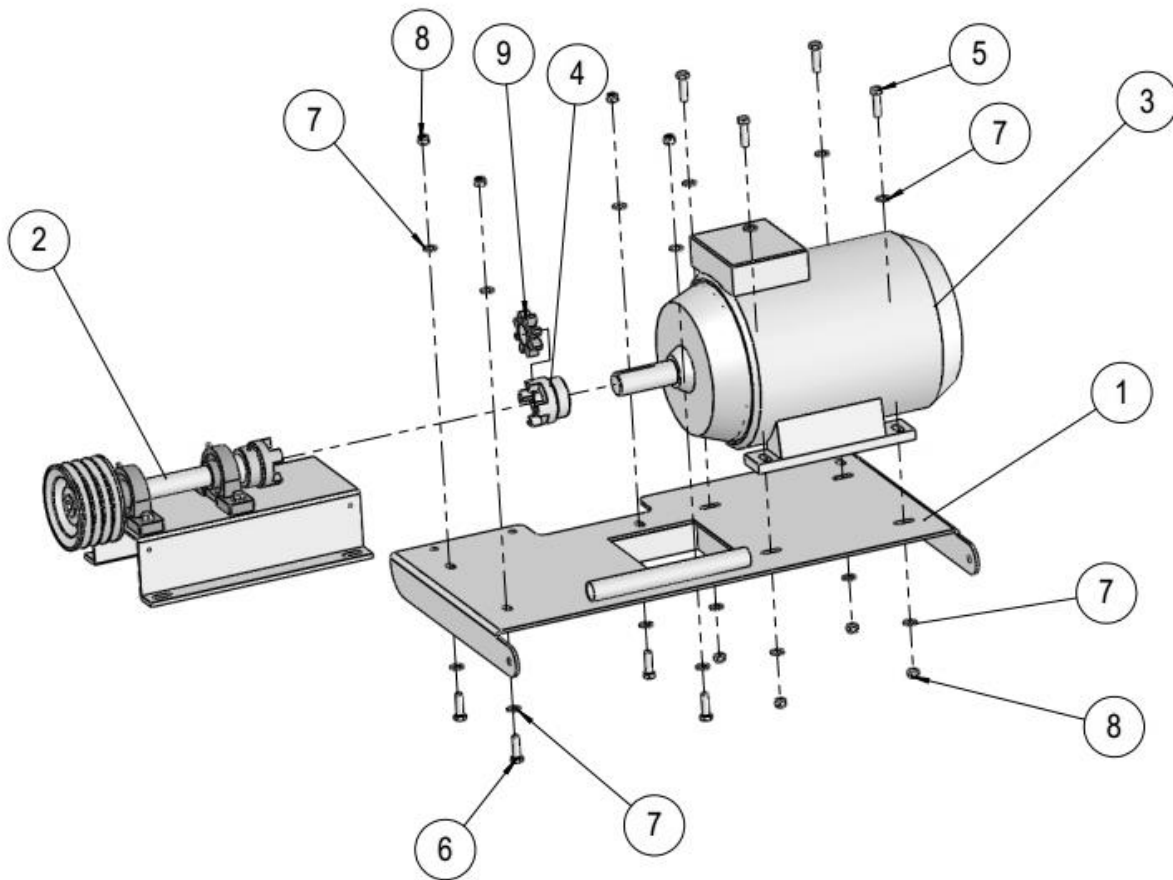

1.46 Electric motor + extension shaft, Combi model parts list (61316)

Number	Name	Part number	Dimensions	Pcs
1	Electric motor bed	61281		1
2	Extension shaft and bearing kit	61314		1
3	Electric motor kit	61340		1
4	Clutch kit	95477		1
5	Hex screw	96149	M12 x 45	4
6	Hex screw	96148	M12 x 40	4
7	Washer	96058	M12/13	16
8	Nyloc nut	96218	M12	8
9	Clutch rubber	95113		1

1.47 Electric motor, Combi model (61340)

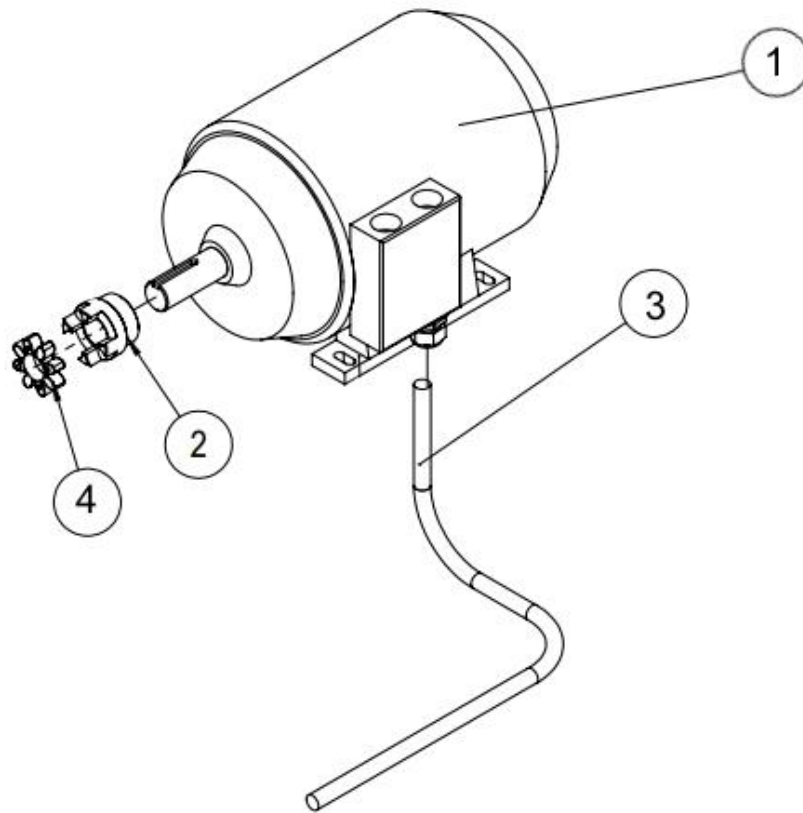

1.48 Electric motor, Combi model parts list (61340)

Number	Name	Part number	Dimensions	Pcs
1	Electric motor 15kW B3	95043		1
2	Clutch kit	95477	D42 – D35	1
3	Rubber cable	95221	7 x 2.5	2.1 m
	Split ring, blue	96372	M6	7
4	Clutch rubber	95113		1

1.49 Power transmission kit, Combi model

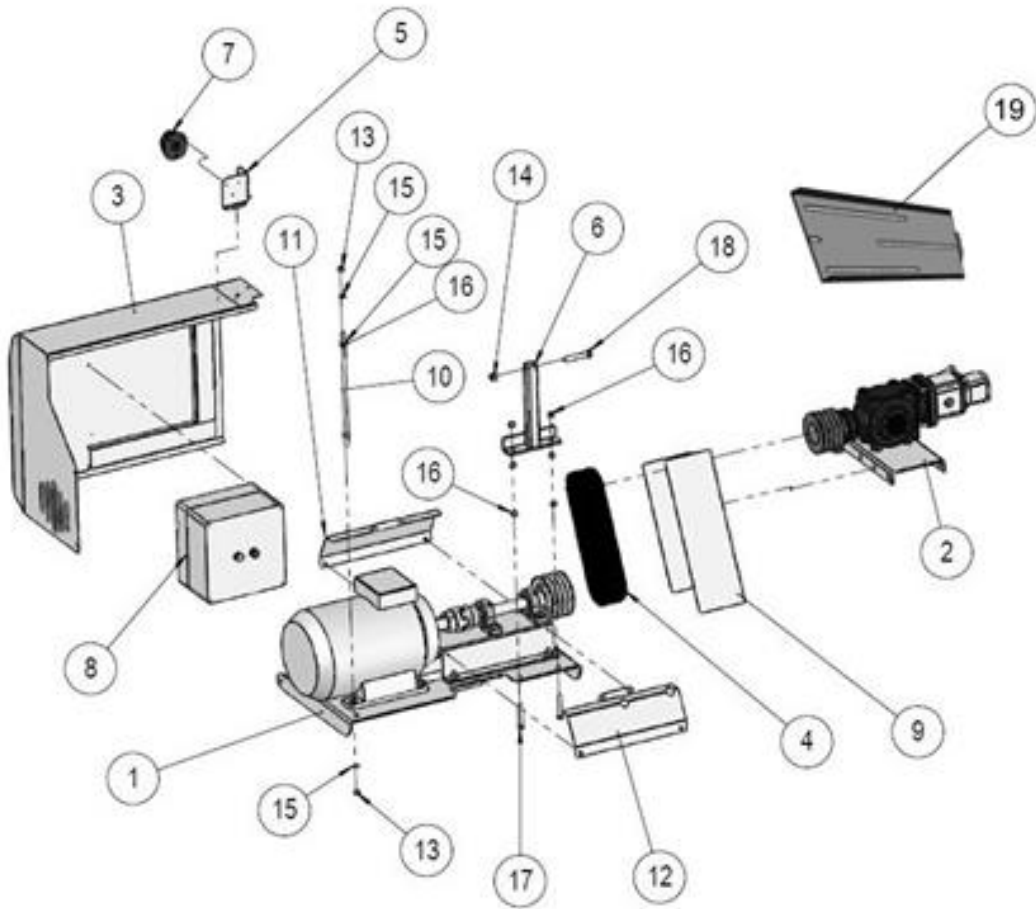

1.50 Power transmission kit, Combi model parts list

Number	Name	Part number	Dimensions	Pcs
1	Electric motor + extension shaft	61316		1
2	Angle gear Combi	61313		1
3	Valve mechanism cover plate	61280		1
4	V-belt B40	95479		4
5	Socket clamp	61312		1
6	Housing clamp support	61295		1
7	Socket assembly	61361		1
8	Starter cover	95157		1
9	Belt guard	61309		1
10	Support rod	61285		1
11	Shaft guard front	61310		1
12	Shaft guard rear	61311		1
13	Nyloc nut	96218	M12	2
14	Nyloc nut	96219	M16	1
15	Washer	96058	M12	4
16	Nut	96200	M12	8
17	Hex screw	96151	M12 x 80	2
18	Hex screw	96118	M16 x 90	1
19	Angle gear cover	47783		1

1.51 Electric motor + pump, electric model (61254)

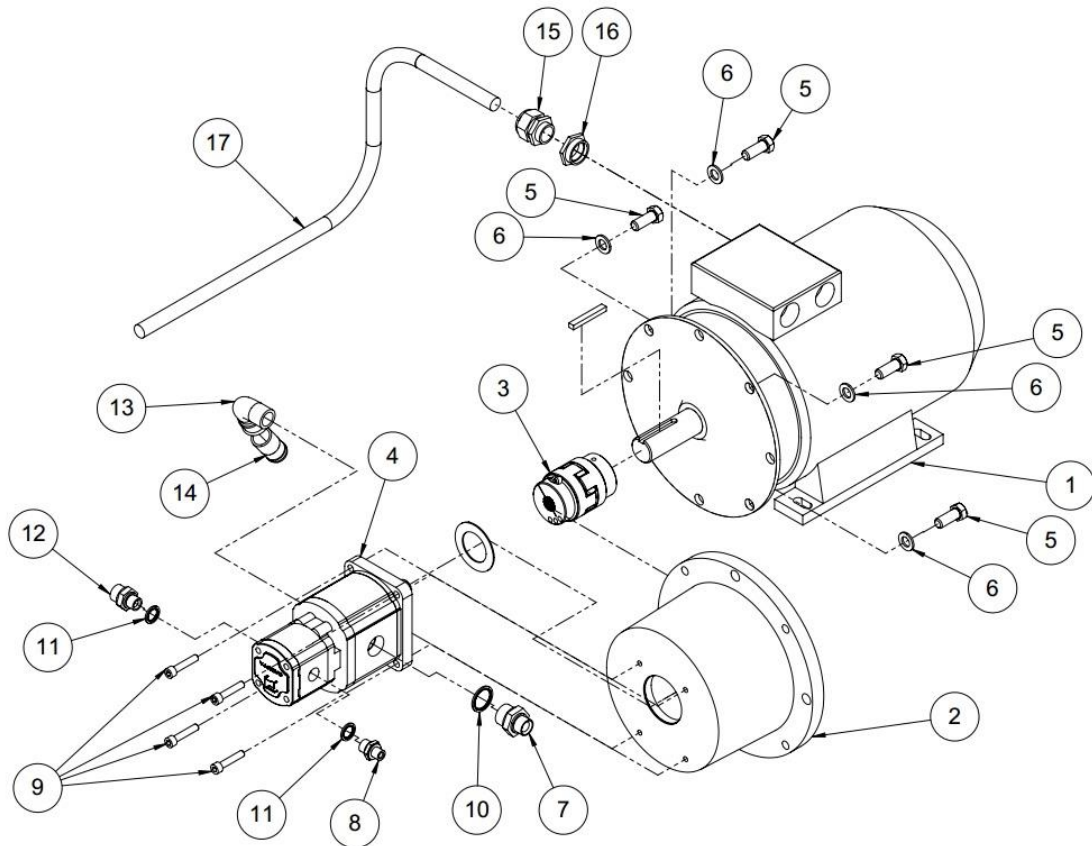

1.52 Electric motor + pump, electric model parts list (61254)

Number	Name	Part number	Dimensions	Pcs
1	Electric motor 15kW B35	95463		1
2	Intermediate flange LS-352	97518		1
3	Clutch kit	97553		1
4	Hydraulic pump	97326		1
5	Hex screw	96154	M16 x 40	4
6	Washer	96059	M16/17	4
7	Double nipple	97208	3/4" / 1"	1
8	Double nipple	97203	3/8" / 1/2"	1
9	Hex socket screw	96011	M10 x 50	4
10	USIT	97215	1"	1
11	USIT	97213	1/2"	2
12	Double nipple	97205	1/2" / 3/4"	1
13	Suction connector	97849	1" / 32 mm	1
14	Hose clamp	97850	43 mm	1
15	Cable clamp	95273	M32 x 1.5	1
16	Adjustment bushing	95274	M40 ext. / M32 int.	1
17	Rubber cable	95221	7 x 2.5	1.7 m

1.53 Norway electric motor + pump (61256)

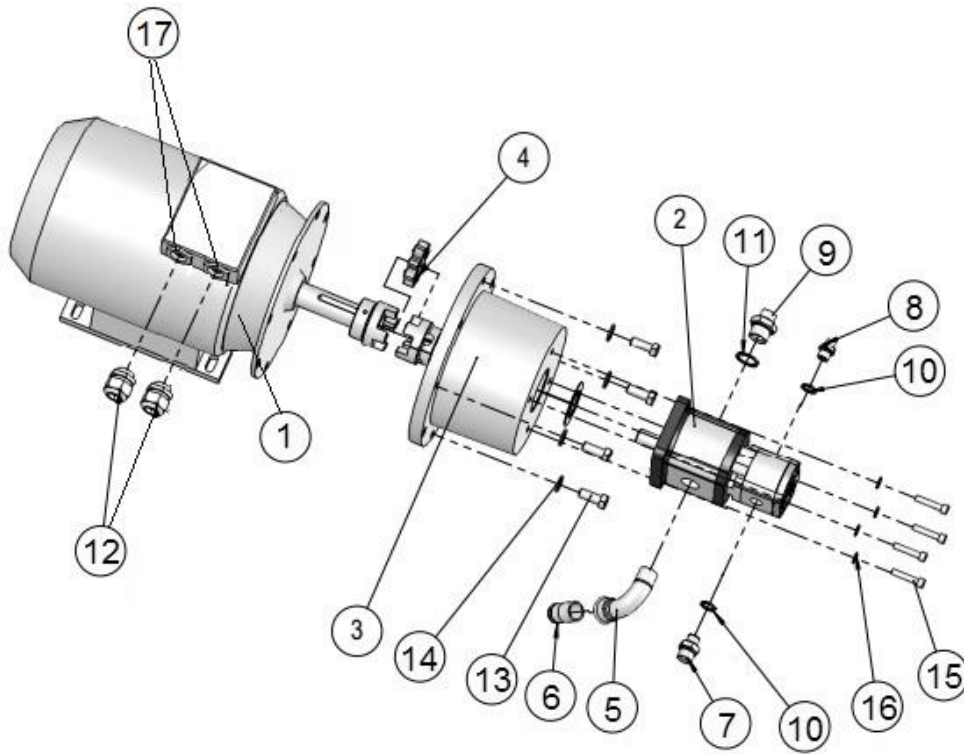

1.54 Norway electric motor + pump parts list(61256)

Number	Name	Part number	Dimensions	Pcs
1	Electric motor B3/B5 230 V	95467		1
2	Hydraulic pump	97326		1
3	Intermediate flange LS-352	97518		1
4	Clutch kit	97553		1
5	Curve	95400	1" internal/external	1
6	Nipple	47112c		1
7	Double nipple	97205	1/2"-3/4"	1
8	Double nipple	97203	3/8" x 1/2"	1
9	Double nipple	97208	3/4"-1"	1
10	USIT	97213	1/2"	2
11	USIT	97215	1"	1
12	Nut	95214	PG 21	2
13	Hex screw	96154	M16 x 40	4
14	Washer	96059	M16/17	4
15	Hex screw	96099	M10 x 50	4
16	Washer	96049	M10	4
17	Gland bushing	95213	PG 21	2

1.55 Log length limiter (61323)

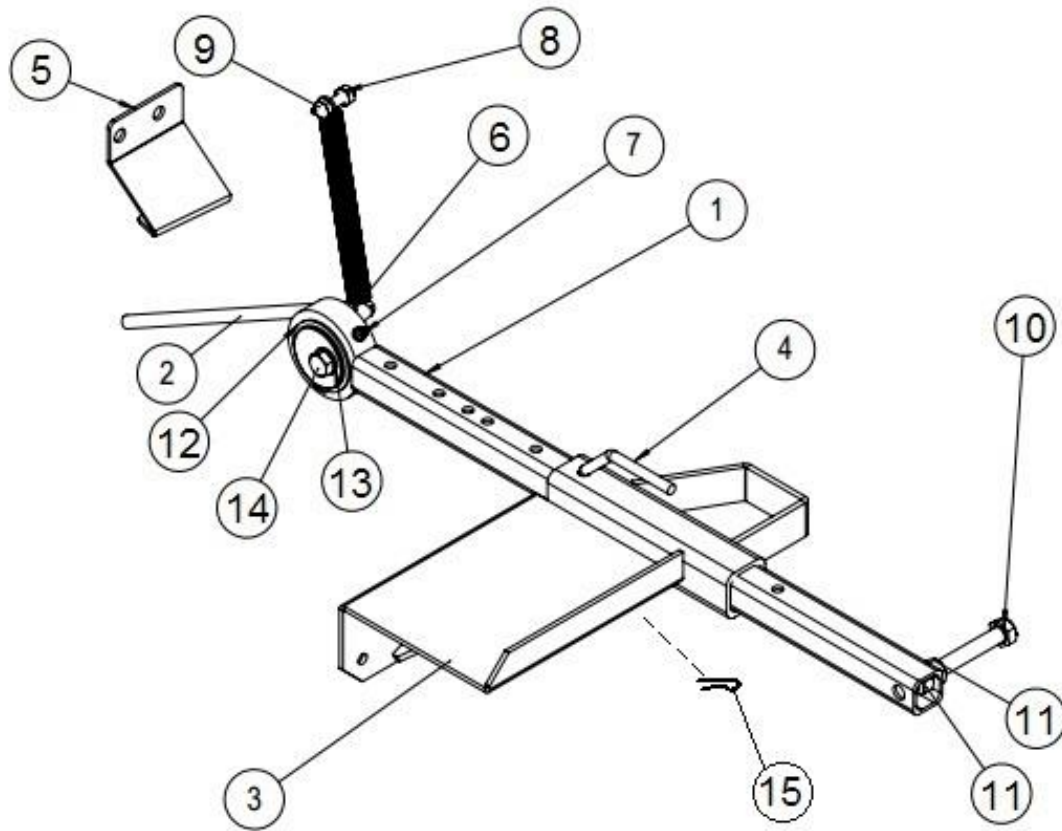

1.56 Log length limiter parts list(61323)

Number	Name	Part number	Dimensions	Pcs
1	Log length limiter pipe	60668		1
2	Eccentric lever	61322		1
3	Log length limiter	60670		1
4	Locking pin	10065		1
5	Lever drive plate	61324		1
6	Draw spring with a stiffener	60677		1
7	Lubrication nipple	96276	M8 x 1	1
8	Nut	96196	M8	1
9	Hex screw	96165	M8 x 30	1
10	Hex screw	96111	M12 x 90	1
11	Nut	96200	M12	2
12	Retaining ring	96046	50	1
13	Washer	96049	M10	1
14	Hex screw	96138	M10 x 20	1
15	Hitch pin	96208		1

1.57 Optical wood measuring device

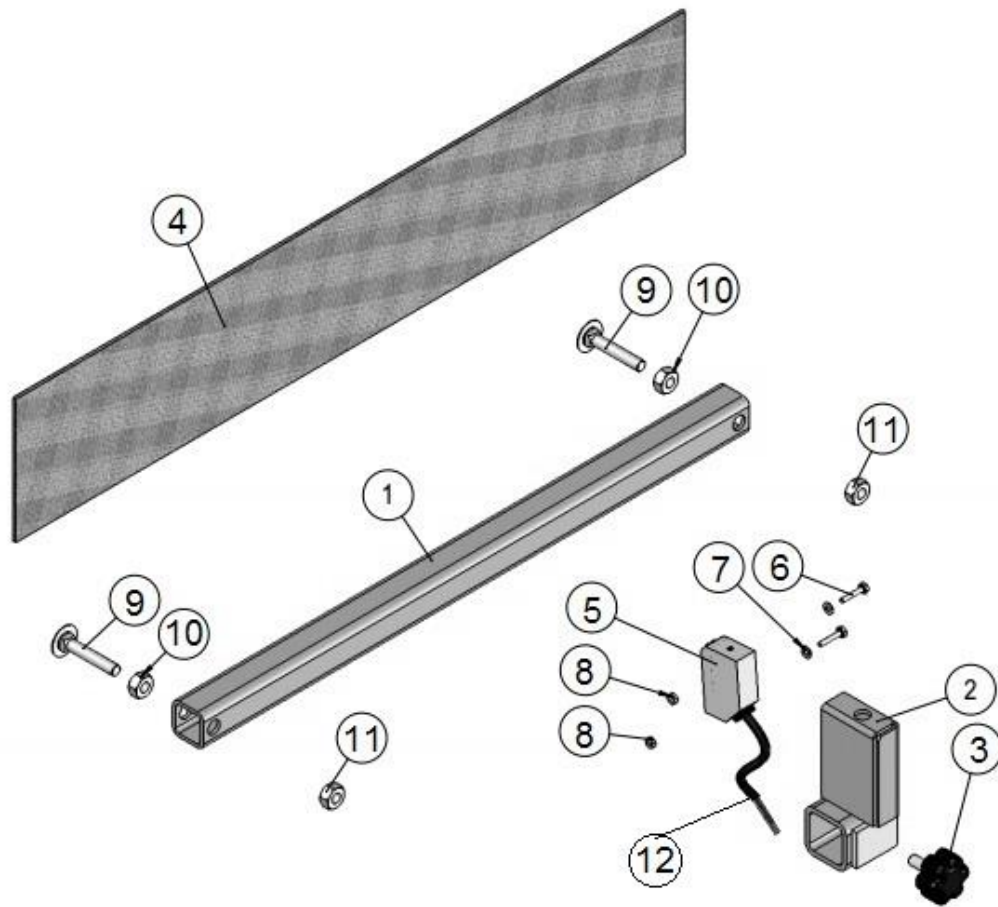

1.58 Optical wood measuring device parts list

Number	Name	Part number	Dimensions	Pcs
1	Optical measuring device pipe	60651		1
2	Optical wood measuring device	47550		1
3	Knurled head screw	95033	M8 x 20	1
4	Reflecting sticker	TR1665		1
5	Photoelectric sensor	95549		1
6	Slot head screw	96261	M4 x 25	2
7	Washer	96313	M4	2
8	Nut	96286	M4	2
9	Lock screw	96342	M10 x 50	2
10	Nyloc nut	96222	M10	4
11	Photoelectric sensor cable	95554		1

1.59 Log guide + splitting blades

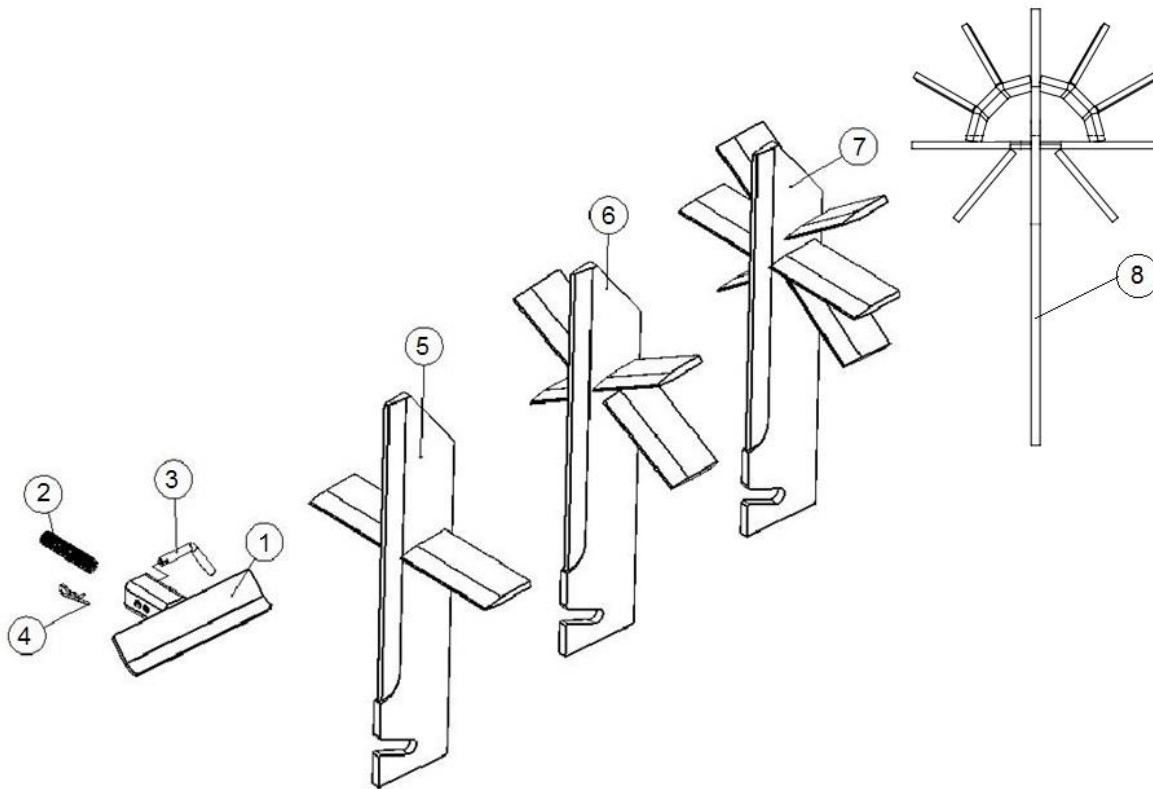

1.60 Log guide + splitting blades parts list

Number	Name	Part number	Dimensions	Pcs
1	Log guide	47390		1
2	Pressure spring	95022	2.5 x 22 x 140	1
3	Locking pin	39050		1
4	Hitch pin	96208		1
5	4-way splitting blade	61205		1
6	6-way splitting blade (accessory)	61104		1
7	8-way splitting blade (accessory)	61207		1
8	12-way splitting blade (accessory)	61212		1

1.61 Front cage, log press (60451) + rear cage (60460)

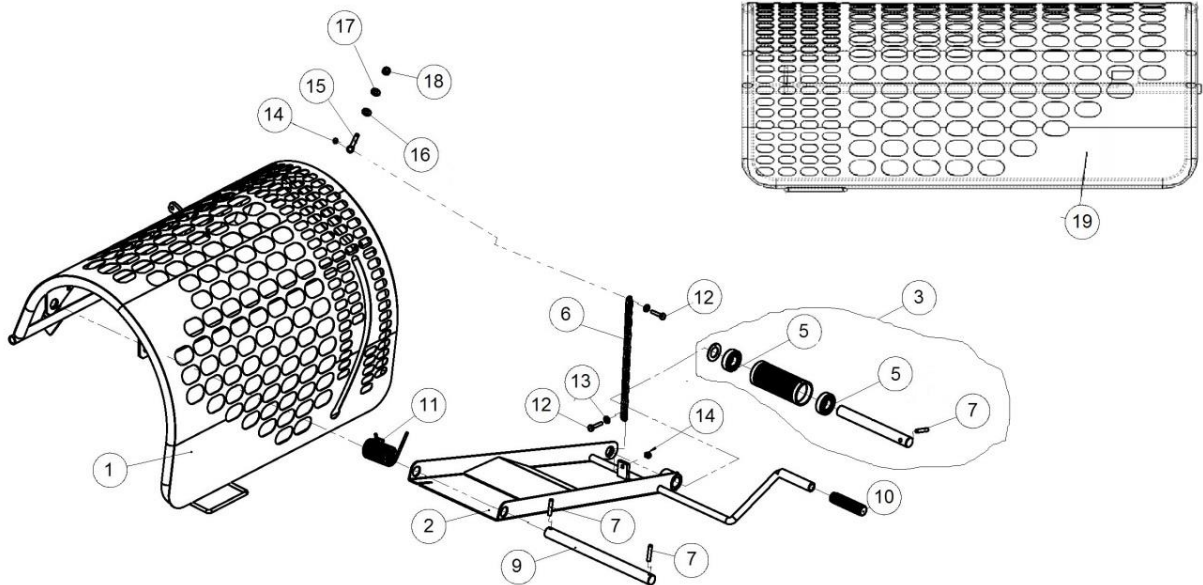

1.62 Front cage, log press (60451) + rear cage (60460)

Number	Name	Part number	Dimensions	Pcs
1	Front cage	60420		1
2	Log press	60430		1
3	Log press roller	10325		1
5	Groove bearing 6205 2rs	95050		2
6	Chain	60444		1
7	Spring pin	96077	8 x 40	3
9	Log press fastening pin	10388		1
10	Handle	95034	22 x 120 mm	1
11	Torsion spring	95027	5 mm	1
12	Hex screw	96131	M8 x 30	2
13	Washer	96057	M8	2
14	Nyloc nut	96217	M8	2
15	Screw hoop	96338	M10 x 90	1
16	Washer	96069	M10	1
17	Nut	96199	M10	1
18	Nyloc nut	96067	M10	1
19	Rear cage	60460		1

1.63 Oil tank + upper guard

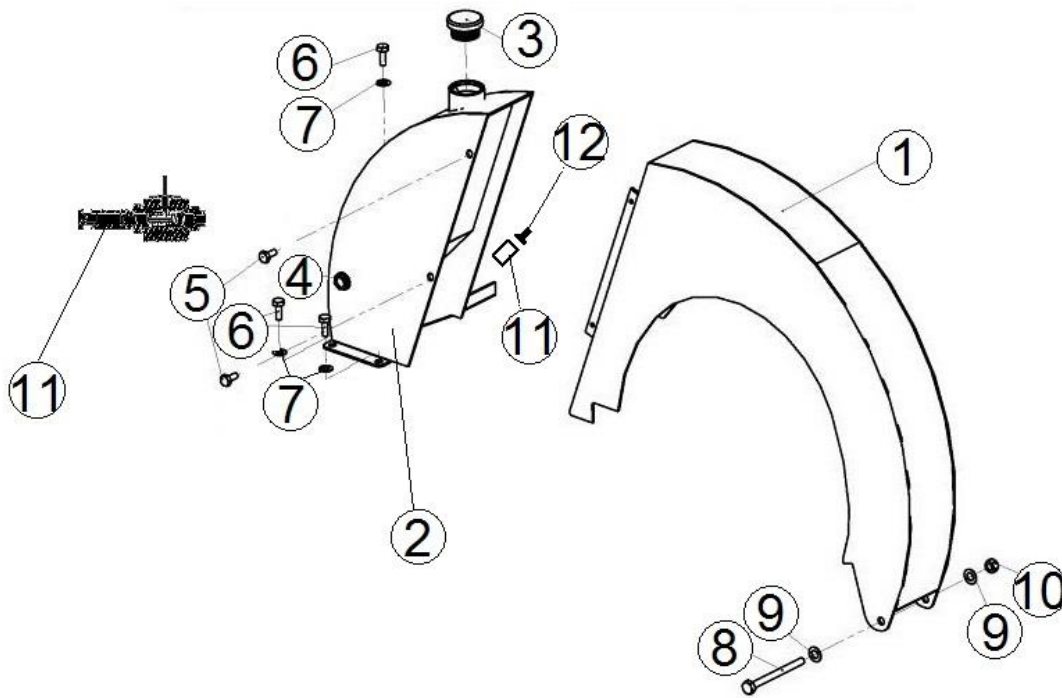

1.64 Oil tank + upper guard parts list

Number	Name	Part number	Dimensions	Pcs
1	Blade guard	61243		1
2	Cutting chain oil tank	61248		1
3	Filler cap	97429		1
4	Oil gauge	97446	1/2"	1
5	Flange bolt	96427	M8 x 12	2
6	Hex screw	96164	M8 x 25	3
7	Sesco washer	96287	M8	3
8	Hex screw	96142	M12 x 120	1
9	Washer	96050	M12	2
10	Nyloc nut	96218	M12	1
11	Cutting chain oil pump	61353		1
12	Internally threaded sleeve	97398	3/8"	1
13	Hose nipple	97281	8 mm	1

1.65 Cutting chain oil pump (50027370)

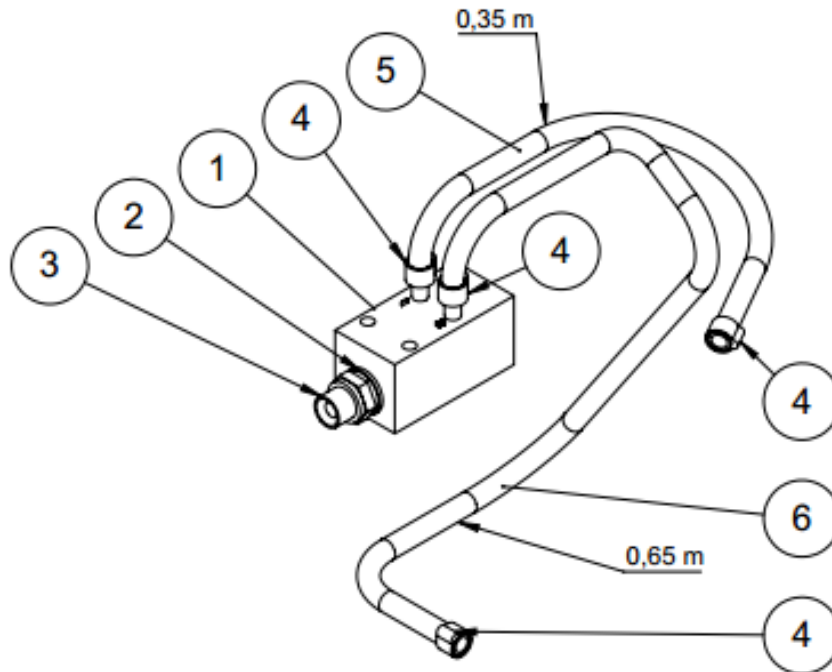

1.66 Cutting chain oil pump parts list (50027370)

Numero	Nimi	Osanumero	Mitat	Kpl
1	Lubriacation pump	97848		1
2	Usit	97212	3/8"	1
3	Throttle nipple 1mm uk/uk	97276	3/8" x 3/8	1
4	Hose clamp	96174	10mm	4
5	ToppFlex hose	95606	35cm	1
6	ToppFlex hose	95606	65cm	1