

FERRI®

www.ferri-america.com



ZT

Extra Reach
ZTE

Offset in-line slope mowers

• Agriculture • Green areas • Tractors from 70 to 80 HP

ZT 2300

 70 to 80 HP  7'5" / 9'4"

ZTE 2300

 70 to 80 HP  7'5" / 10'9"

Strong points

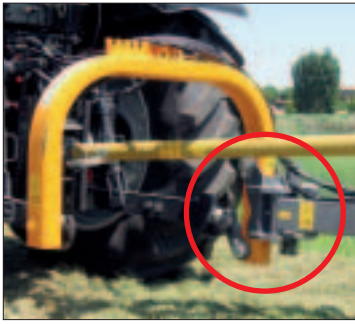

Floating frame: the joint pin on tractor side allows the head system to follow the ground, protecting the arms structure of the parallelogram.



Hydraulic sideshift ram fitted within parallel arms.



Gearbox inside the transmission cover. Rear adjustable roller \varnothing 5 1/2".



The gearbox position located outside of the transmission cover allows greater off-set of the flail head reducing the Pto shaft angle in work (**only ZTE**).



Tap for the locking of the machine in transport position.



Mechanical breakaway



Cable controls with floating head (optional).

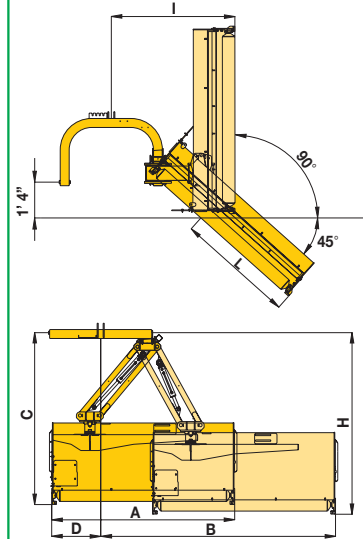

Work position

- In-slope
- Vertical
- Offset
- In-line



	ZT 2300	ZTE 2300
A ft.	7'5"	7'5"
B ft.	9'4"	10'9"
C ft.	5'10"	5'10"
D ft.	2'1"	0'11" - 0'81"
H ft.	6'4"	6'4"
I ft.	4'11"	4'11"
L ft.	5'5"	6'6"

Equipment

	MOD.	ZT 2300	ZTE 2300
Cutting width	ft	7'5"	7'5"
Max sidesliding*	ft	9'14"	10'9"
Power take-off	RPM	540	540
Belts	No.	4	4
Tractor required power	HP	70 / 80	70 / 80
Rotor speed	RPM	2325	2325
Blade tip speed	ft/sec	164'	164'
Weight	lbs	1444	1444
Three point linkage	Cat.	II	II
Tractors minimum width	ft	7'3"	7'3"
 Multiuse blades for grass, shrubs, bushes, max. 1 1/4"	No.	66	66
 Hammer blades for wood, twigs, grass max. 1 3/4"	No.	22	22